

Most - Often - Needed

1959

Volume 19

**RADIO
DIAGRAMS**

and Servicing Information



Compiled by
M. N. BEITMAN

SUPREME PUBLICATIONS

RADIO DIAGRAM MANUALS

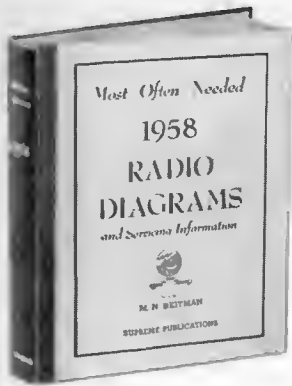

New 1958 **VOLUME 18**
Price **\$2.50**

Repair quickly all new 1958 sets as well as older radios. This big volume contains clearly printed, large schematics, needed alignment data, replacement parts lists, voltage values, and information on stage gain, location of trimmers, and dial stringing, for all important new 1958 sets. Includes material on portables, clock radios, record changers, FM, and auto sets. A worthy companion to seventeen previous volumes used by over 143,000 shrewd radio servicemen. Large size: 8½ x 11 inches. Manual style binding. Postpaid, only **\$2.50**

RADIO DIAGRAMS FOR PREVIOUS YEARS

Speed up and simplify all radio repairs. Service radios faster, better, easier, save money and time, use these **SUPREME Most-Often-Needed** diagram manuals to get ahead. At the low cost (only \$2 for most volumes) you are assured of having for every job needed diagrams and other essential repair data on 4 out of 5 sets you will ever service. Clearly printed circuits, parts lists, alignment data, and helpful service hints are the facts you need. Average volume has 192 pages, large size 8½ x 11 inches. Manual style binding.

- | | | | | | |
|---|---|---|---|---|---|
| <input type="checkbox"/> 1957
Volume 17
\$2.50 | <input type="checkbox"/> 1956
Volume 16
\$2.50 | <input type="checkbox"/> 1955
Volume 15
\$2.00 | <input type="checkbox"/> 1954
Volume 14
\$2.50 | <input type="checkbox"/> 1953
Volume 13
\$2.50 | <input type="checkbox"/> 1952
Volume 12
\$2.50 |
| <input type="checkbox"/> 1951
Volume 11
\$2.50 | <input type="checkbox"/> 1950
Volume 10
\$2.50 | <input type="checkbox"/> 1949
Volume 9
\$2.50 | <input type="checkbox"/> 1948
Volume 8
\$2.00 | <input type="checkbox"/> 1947
Volume 7
\$2.00 | <input type="checkbox"/> 1946
Volume 6
\$2.00 |
| <input type="checkbox"/> 1942
Volume 5
\$2.00 | <input type="checkbox"/> 1941
Volume 4
\$2.00 | <input type="checkbox"/> 1940
Volume 3
\$2.00 | <input type="checkbox"/> 1939
Volume 2
\$2.00 | <input type="checkbox"/> 1926-1938
Volume 1
\$2.50 | |

INDEX for all Radio and TV Manuals **25¢**

RADIO SERVICING COURSE

Here is your practical radio course of 22 easy-to-follow lessons. Review fundamentals, learn new servicing tricks. Just like a \$200.00 correspondence course. Everything in radio servicing. With self-testing questions. **\$250**
New edition. Price only

Simplified Radio Servicing by COMPARISON Method

Revolutionary different **COMPARISON** technique permits you to do expert work on all radio sets. Most repairs can be made without test equipment or with only a volt-ohmmeter. Many simple, point-to-point, cross-reference, circuit suggestions locate the faults instantly. Plan copyrighted. Covers every radio set - new and old models. This new servicing technique presented in handy manual form, size 8½ x 11 inches, 92 pages. Over 1,000 practical service hints. 26 large, trouble-shooting blueprints. Charts for circuit analysis. 114 tests using a 5c resistor. Developed by M. N. Beitman. New edition. Price only **\$1.50**



How to Modernize Radios

Cash in by improving and modernizing all out of date radio sets and cabinets. Practical job-sheets with schematics and photographs make this work easy. Size 8½ x 11 inches. Your price only **\$1**



SUPREME TELEVISION MANUALS



1959 TV Manual, TV-15

This new giant volume of 1959 television factory data will give you everything you need to repair and adjust all present-day TV sets. The **television series** manuals are amazing bargains and defy competition. The 1959 volume contains circuit explanations, 192 pages of alignment facts, test patterns, response curves, waveforms, voltage charts, hints, and dozens of mammoth double-page work-bench diagrams. Large size 8½ x 11 inches. Sturdy covers. Book binding opens flat. Amazing value. Price postpaid, only **\$3**

EARLIER TV MANUALS FOR 1958 TO 1948

Supreme TV manuals cover all needed service material on every popular TV set of every important manufacturer. Here is helpful, practical, factory-prepared data that will really make TV servicing and adjustment easy for you. **Supreme** giant TV manuals have complete circuits, alignment facts, test patterns, response curves, service hints, recommended changes, voltage charts, waveforms, and many double-page diagram blueprints. Here is your TV service material to help you do more expert work quicker; and priced at only \$3. **Radio** manuals described at left.

- | | | | |
|--|--|---|--|
| <input type="checkbox"/> 1958 Television Manual, TV-14, \$3. | | | |
| <input type="checkbox"/> ADDITIONAL 1957 TV, Vol. TV-13, \$3. | | | |
| <input type="checkbox"/> EARLY 1957 TV Manual, TV-12, \$3. | | | |
| <input type="checkbox"/> 1956 TV Volume TV-11 \$3.00 | <input type="checkbox"/> 1955 TV Additional, TV-10 \$3.00 | <input type="checkbox"/> 1955 TV Early, Vol. TV-9 \$3.00 | <input type="checkbox"/> 1954 TV Volume TV-8 \$3.00 |
| <input type="checkbox"/> 1953 TV Volume TV-7 \$3.00 | <input type="checkbox"/> 1952 TV Volume TV-6 \$3.00 | <input type="checkbox"/> 1951 TV Volume TV 5 \$3.00 | <input type="checkbox"/> 1950 TV Volume TV-4 \$3.00 |
| <input type="checkbox"/> 1949 TV Volume TV-3 \$3.00 | <input type="checkbox"/> 1948 TV Volume TV-2 \$3.00 | <input type="checkbox"/> 1957-58 RCA Volume \$1.50 | |

TELEVISION SERVICING COURSE

Let this new course teach you TV servicing. Amazing bargain, complete only \$3, full price for all lessons. Giant in size, mammoth in scope, topics just like a \$200.00 correspondence course. Lessons on picture faults, circuits, adjustments, short-cuts, UHF, alignment hints, antenna problems, trouble-shooting, test equipment, picture analysis. Special, only **\$3**

RADIO MATHEMATICS

Explains arithmetic and simple algebra in connection with units, color code, meter scales, Ohm's law, alternating currents, ohmmeter testing, wattage rating, series and parallel connections, capacity, inductance, mixed circuits, vacuum tubes, curves, the decibel, etc., and has numerous examples. Only **25¢**

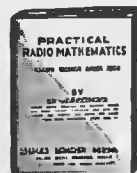

Practical Radio & Electronics Course

Here is your complete home study course of 35 lessons designed to train any beginner to be an expert in radio and electronics. Covers every topic of radio, electronics, with lessons on test equipment, FM, TV, radio, etc. Giant 8½ x 11 inches, 3-in-1 volume, includes all lessons, instructor's notes, test questions. New edition. Only **\$395**

ANSWER BOOK to the above course **25¢**

Admiral

CHASSIS 6T2
MODELS 521 • 528

I. F. 455 KC.

TOTAL CURRENT DRAIN APPROXIMATELY
10.5 MA WITH VOLUME CONTROL AT MINIMUM
AND NO SIGNAL APPLIED.

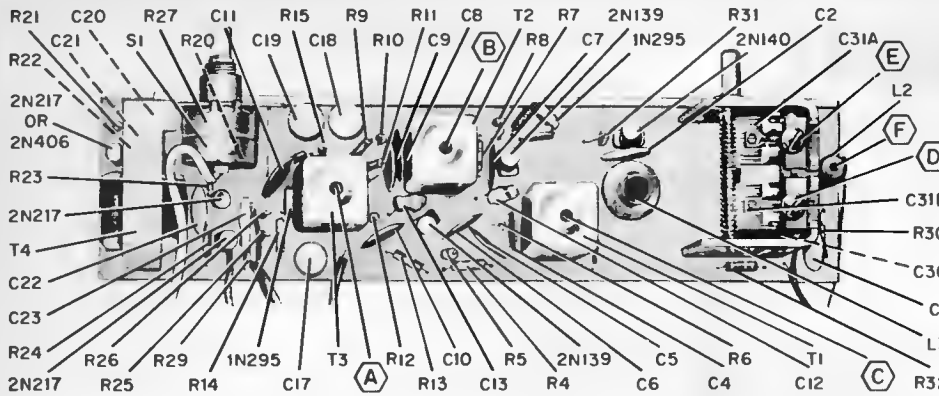

REMOVING THE CHASSIS

1. Remove **Tuning** knob and **Volume** control knob by working them forward and off the shaft.
2. Open cover on rear of cabinet.
3. Remove the battery case.
4. On the front of the cabinet, *loosen* the two Phillips head screws adjacent the tuning shaft.
5. *Loosen* the hex nut that secures the **Volume** control to front of case.
6. Hold the printed circuit board while removing the two screws and hex nut, to prevent damage.
7. Gently lift the circuit board from within cabinet.

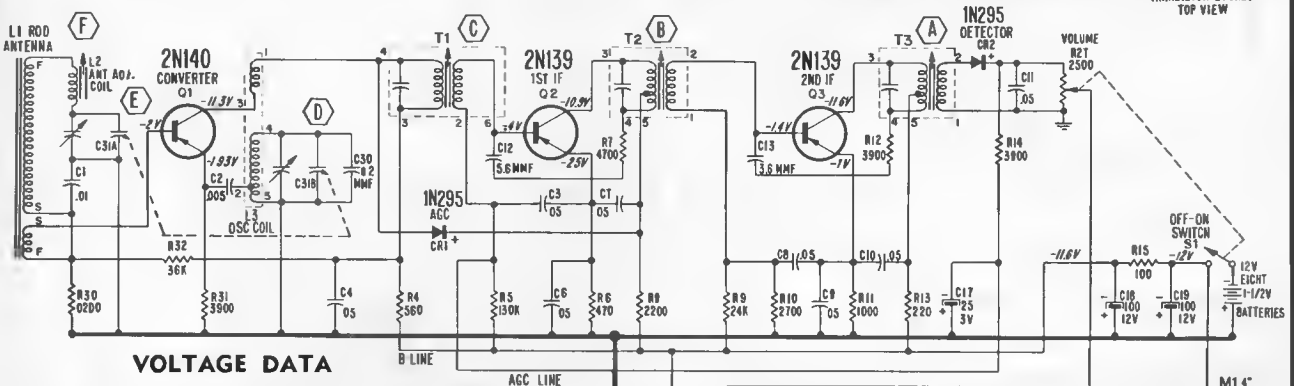

VOLTAGE DATA

DC voltages shown measured with no signal, using fresh batteries.

Volume control at minimum; dial set a low frequency end.

All readings made between transistor socket terminals and B plus (ground).

All voltage readings are negative.

- NOTES
IF - 455K
— CHASSIS GROUND
— COMMON GROUND
* MATCHED PAIR
CAPACITOR VALUES IN MICROFARADS UNLESS OTHERWISE SPECIFIED
† NOT USED ON ALL CHASSIS.

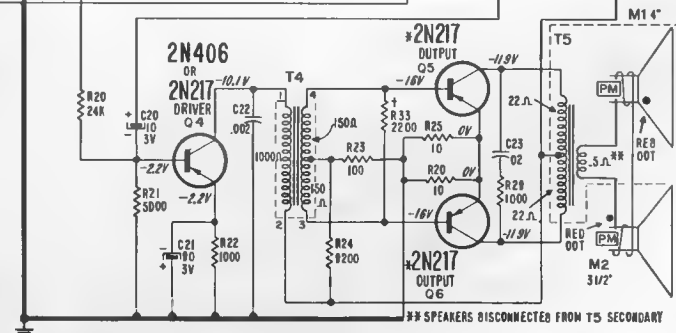
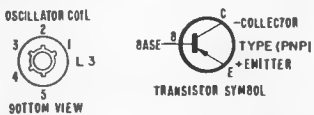

View of Printed Wiring Board. NOTE: Gray area represents printed wiring; block symbols and lines represent components and wiring on opposite side.

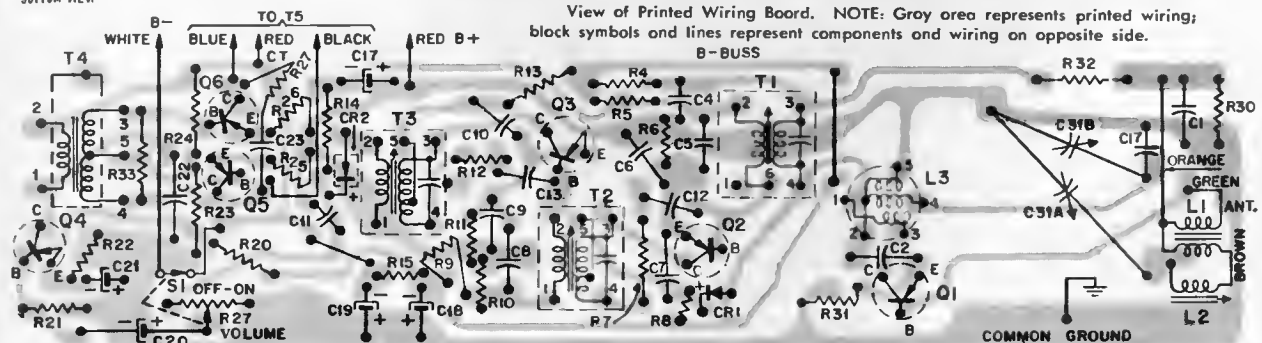

Admiral

CHASSIS 8M1 MODELS 801 • 802 • 808

REMOVING THE CHASSIS

To remove the cabinet front from the chassis, proceed as follows:

1. Remove the battery compartment cover.
2. Remove the batteries.
3. Remove the four Phillips head screws that are visible within the battery compartment.
4. The tuning knob hub is a thumb screw. Remove it by turning counterclockwise.
5. Remove tuning knob by working it forward and off the tuning shaft.

6. Remove the Phillips head screw at the left of the tuning shaft.
7. Gently lift the cabinet front from the cabinet back and chassis.

To remove chassis from cabinet back for servicing the wiring side of the chassis:

8. Make sure tuning gang is closed. Then remove the two Phillips head screws that are visible—one near the tuning capacitor and the other in lower left corner as radio is viewed from the front.
9. Lift speaker from cabinet and away from chassis.
10. Gently lift out wiring side of chassis from cabinet.

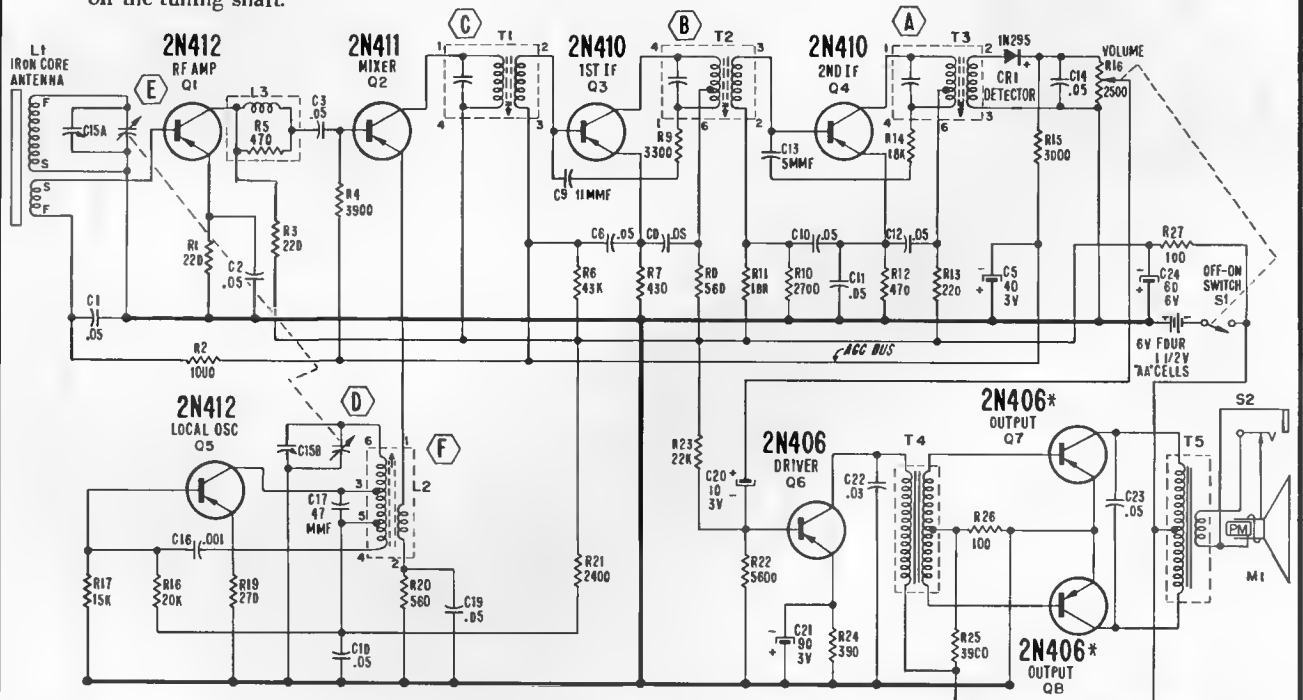

IF = 455 KC
 COMMON GROUND (B+)
 * MATCHED PAIR
 CAPACITOR VALUES IN MICROFARADS UNLESS OTHERWISE SPECIFIED



I. F. 455 KC.

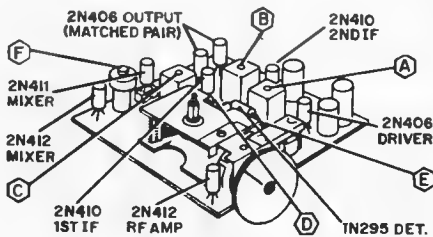

Transistor and Alignment Locations

VOLTAGE DATA

Voltages shown measured with no signal, using fresh batteries. Volume control at minimum; dial set at low frequency end. All readings made with VTVM between emitter terminals and B plus (ground). All voltages are negative.

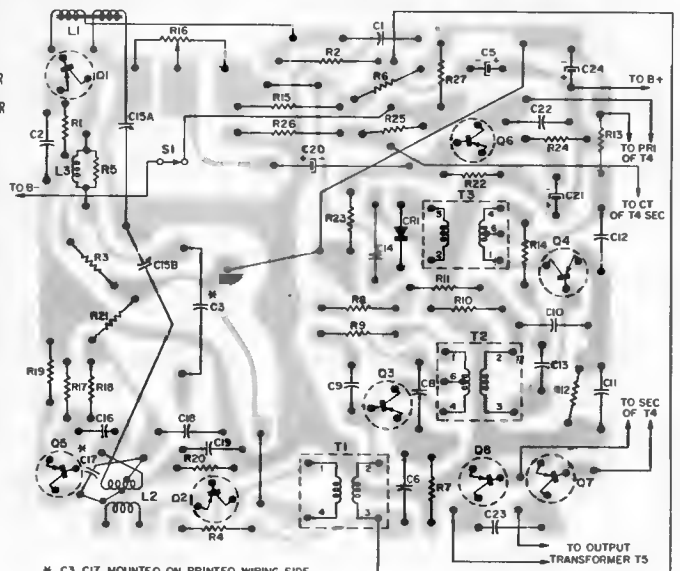

* C3, C17 MOUNTED ON PRINTED WIRING SIDE

View of Printed Wiring Board. Gray area represents printed wiring, black symbols and lines represent components.

Admiral

Models 392, 393, 462, and 463.

7N1 and 7N1A AM-FM TUNERS and 4S2 HI-FI AMPLIFIER

(Continued from page 6)

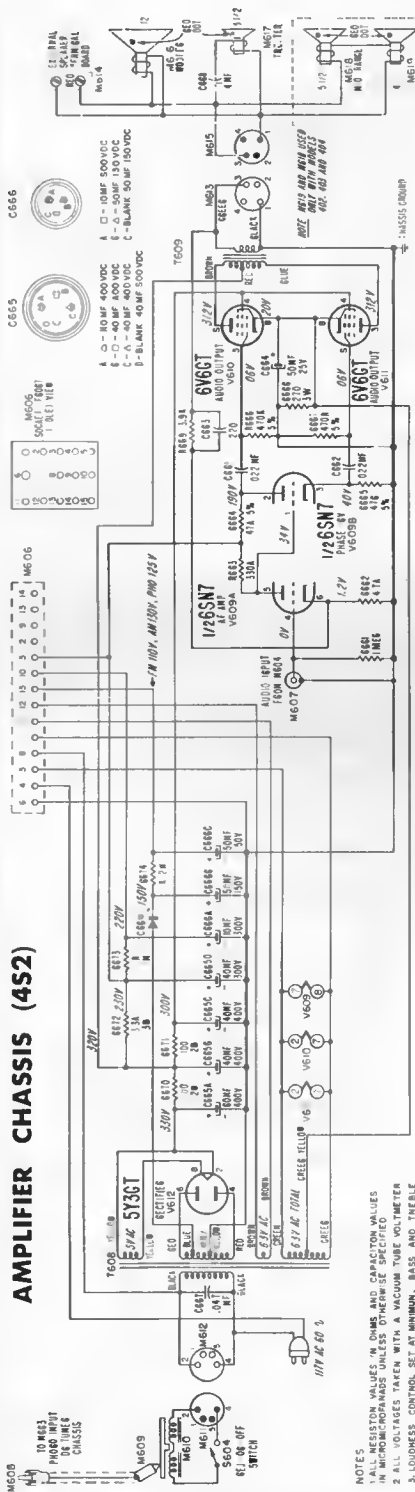

NOTES
 1. ALL RESISTOR VALUES IN OHMS AND CAPACITOR VALUES IN MICROGRAMS UNLESS OTHERWISE SPECIFIED.
 2. ALL VOLTAGES TAKEN WITH A VACUUM TUBE VOLTMETER CONTROLS AT MID POSITION AND NO SIGNAL APPLICABLE FOR ALL VOLTAGE READINGS.
 3. AMPIFIER AND TUNER CONNECTED FOR ALL VOLTAGE READINGS.

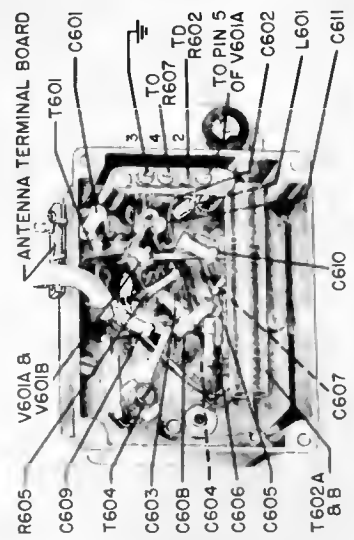

ANTENNA TERMINAL BOARD
 Bottom View of FM Tuner Sub-chassis.
 Location of components shown.

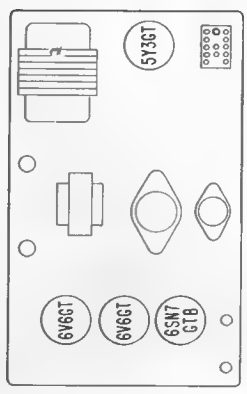

Top View of Amplifier Chassis.
 Tube locations shown.

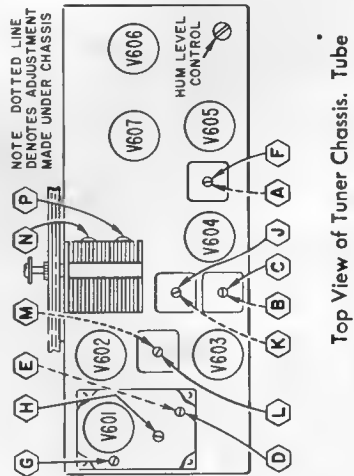

Top View of Tuner Chassis. Tube locations and alignment points shown.

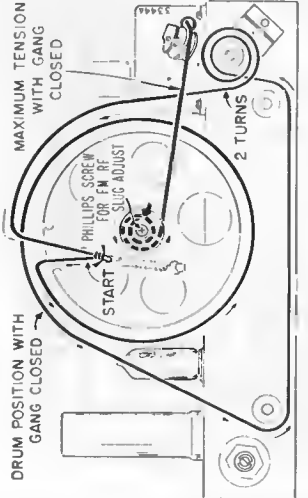

Dial Stringing (Early Production).

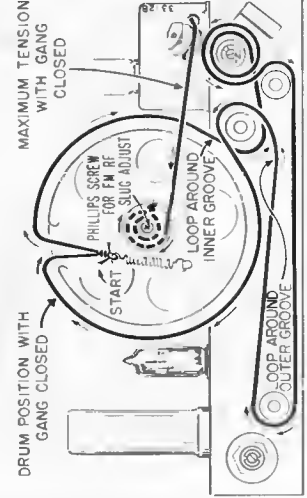

Dial Stringing (Present Production).

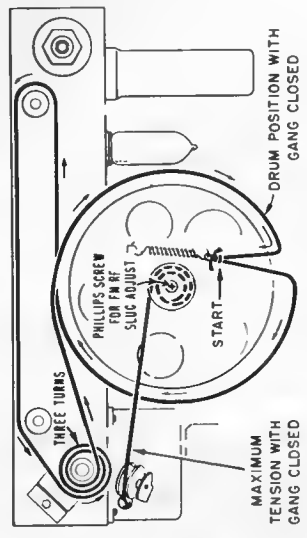

Dial Stringing (Chassis 7N1A).

Material applicable to 7N1 and 7N1A Tuners and 4S2 Amplifier.

Admiral

Chassis 8S1, Models 561, 566, exact material.
Chassis 8S1A, Models 811, 816, include clock.

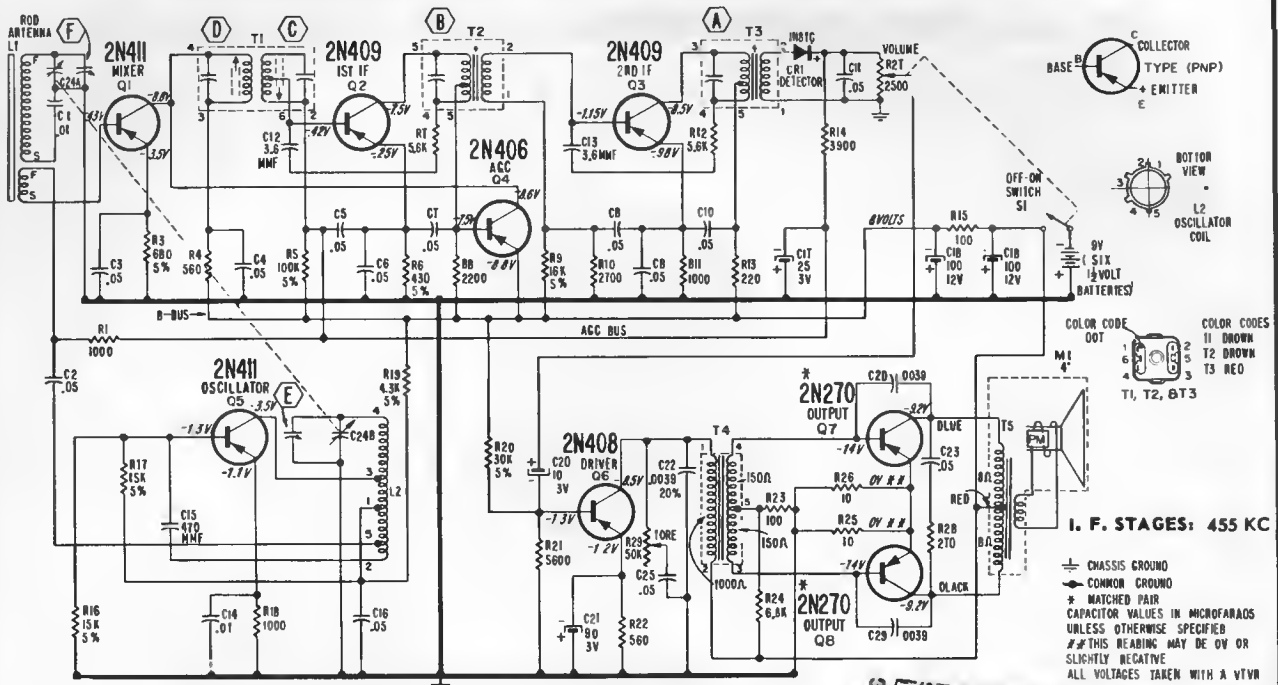

1. Remove 2 screws near front edge of cabinet bottom.
2. Remove 2 screws from upper section of cabinet back.
3. Pull chassis and front panel free of cabinet.

The speaker, volume and tone control, and printed chassis board are all fastened separately with screws to the front panel. Remove them individually as required by removing their mounting screws.

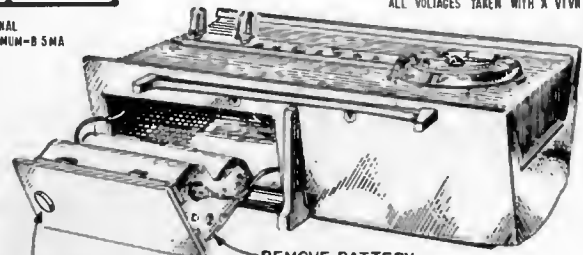

REMOVE BATTERY CASE FROM CABINET

Removing Battery Case.

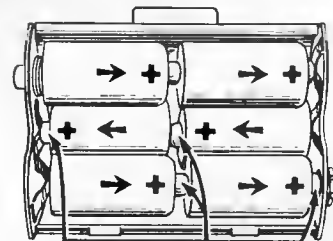

CENTER CAPS (POSITIVE TERMINALS(+))

Battery Case Showing Batteries in Correct Position.

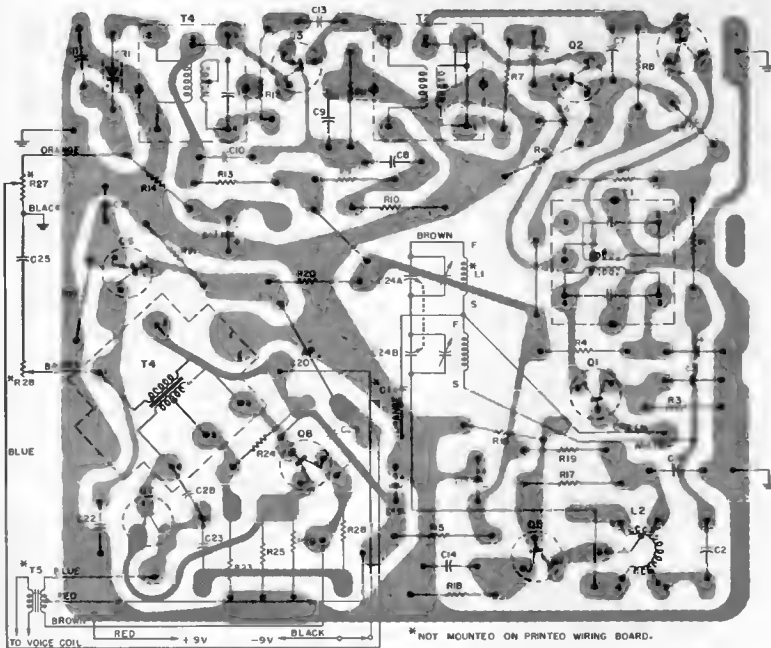

View of Printed Wiring Board. Gray area represents printed wiring, black symbols and lines represent components.

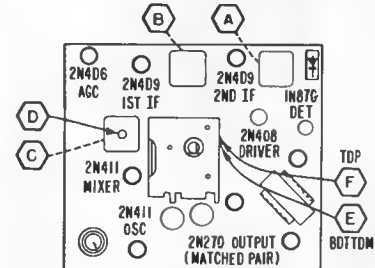

NOTE: DOTTED LINES INDICATE ADJUSTMENT UNDER BOARD

Transistor and Alignment Locations.

Admiral 12B1-12B1A-5T4A CHASSIS

Models 632, 633, 634, 642, 643, 644, 649, 654, 662, 663, 664, 671, use Chassis 12B1. Chassis 12B1A has a different panel; used in later Model 649. Same model numbers with prefix SS use auxiliary stereo unit 5T4A.

(Additional material on pages 10-11)

Run changes refer to 12B1 schematic diagram on next two pages.

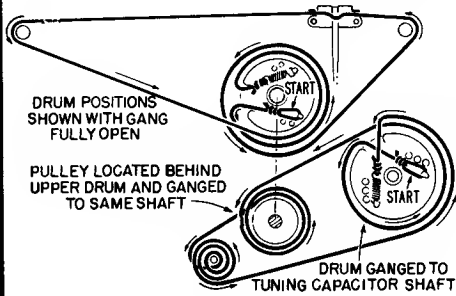

Stringing Diagram.
(Early Production)

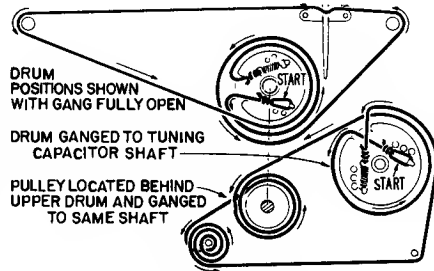

Stringing Diagram.

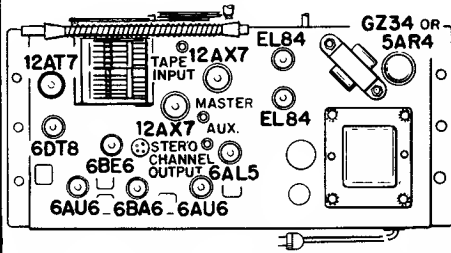

Top View of 12B1 Chassis, Tube Locations Shown.

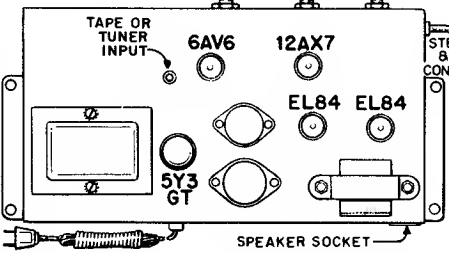

Top View of 5T4A Chassis

- ⑩ Start of production 12B1.
- ⑪ R25 (15K, 1W) changed to (22K, 1W) to permit full interchangeability 6B6E tubes. R33 changed to (390K, 1/2W); R34 to (100K, 1/2W); and C39 to (.002MF) to improve AM operation. R70 (470K, 1/2W) added between M11 and M12 to minimize rumble.
- ⑫ R70 (470K, 1/2W) removed to increase channel separation for stereo operation.
- ⑬ To insure proper operation of OFF-ON-POWER relay at low line voltages, R45 (39K, 2W) removed and R71 (33K, 2W) added in its place.
- ⑭ To reduce possibility of regeneration in strong signal areas, C18 (.02MF) and C21 (.02MF) removed. R72 (75K, 5%) and R73 (75K, 5%) added to IF section. R65 (160K) connected to B + 200V. For standardization of parts, C19A and B (.001MF) V2 screen and filament bypass removed. C19 (.01MF) V2 screen bypass and C72 (.005MF) V2 filament bypass added. C22A and B (.001MF) V3 screen and filament bypass removed. C22 (.01MF) V3 screen bypass and C73 (.005MF) V3 filament bypass added. C24A and B (.001MF) V4 screen and filament bypass removed. C24 (.01MF) V4 screen bypass and C74 (.005MF) V4 filament bypass added. V8 changed to ECC83. For improved frequency response, C55 changed to .02MF, C64 changed to .02MF. C66 and C67 each changed to .02MF. C75 (.001MF) added from plate to screen of V12. C76 (.001MF) added from plate to screen of V12. To increase AM audio output, R33 changed to 100K and R34 changed to 390K. R74 (100K, 1W) added.
- ⑮ R75 (10 ohms, 1/2 watt) added between pin 2 of V1B and R2 to reduce possibility of RF regeneration.

Schematic of 5T4A Amplifier Chassis Stamped Run 10.

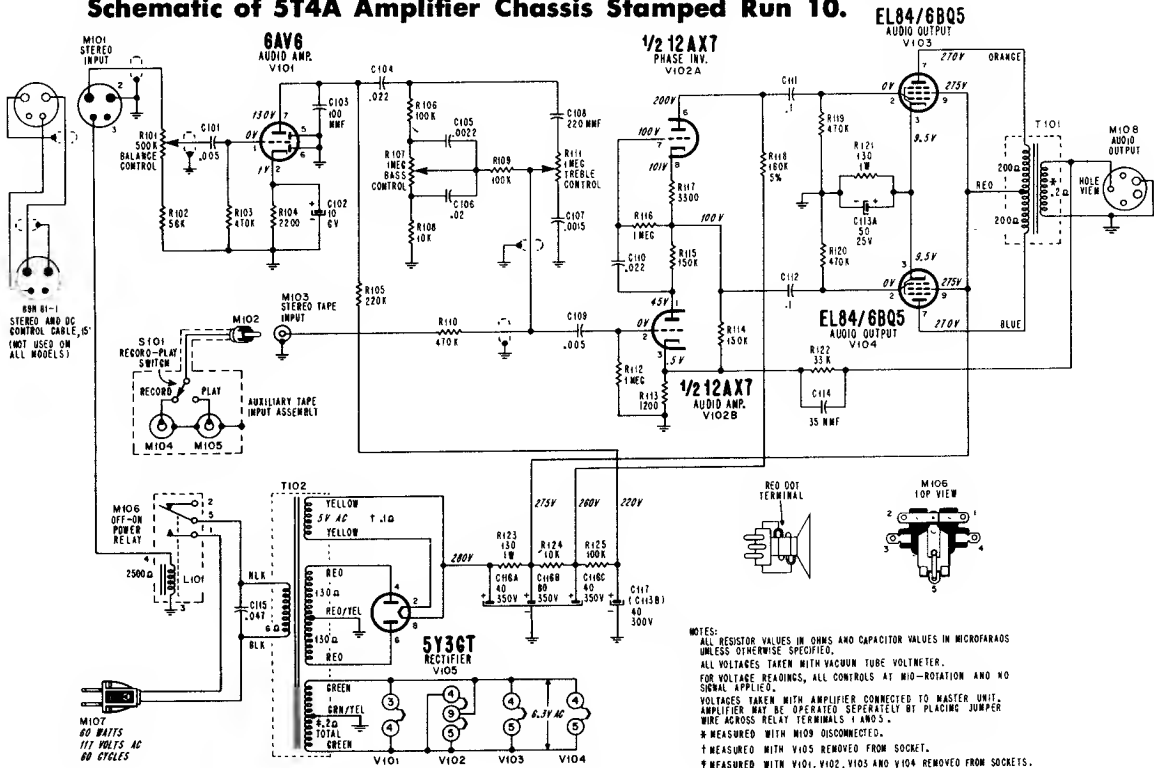

VOLUME R-19, MOST-OFTEN-NEEDED 1959 RADIO SERVICING INFORMATION

ADMIRAL Schematic Diagram of 12B1-12B1A Radio Chassis Stamped Runs 10 through 15.

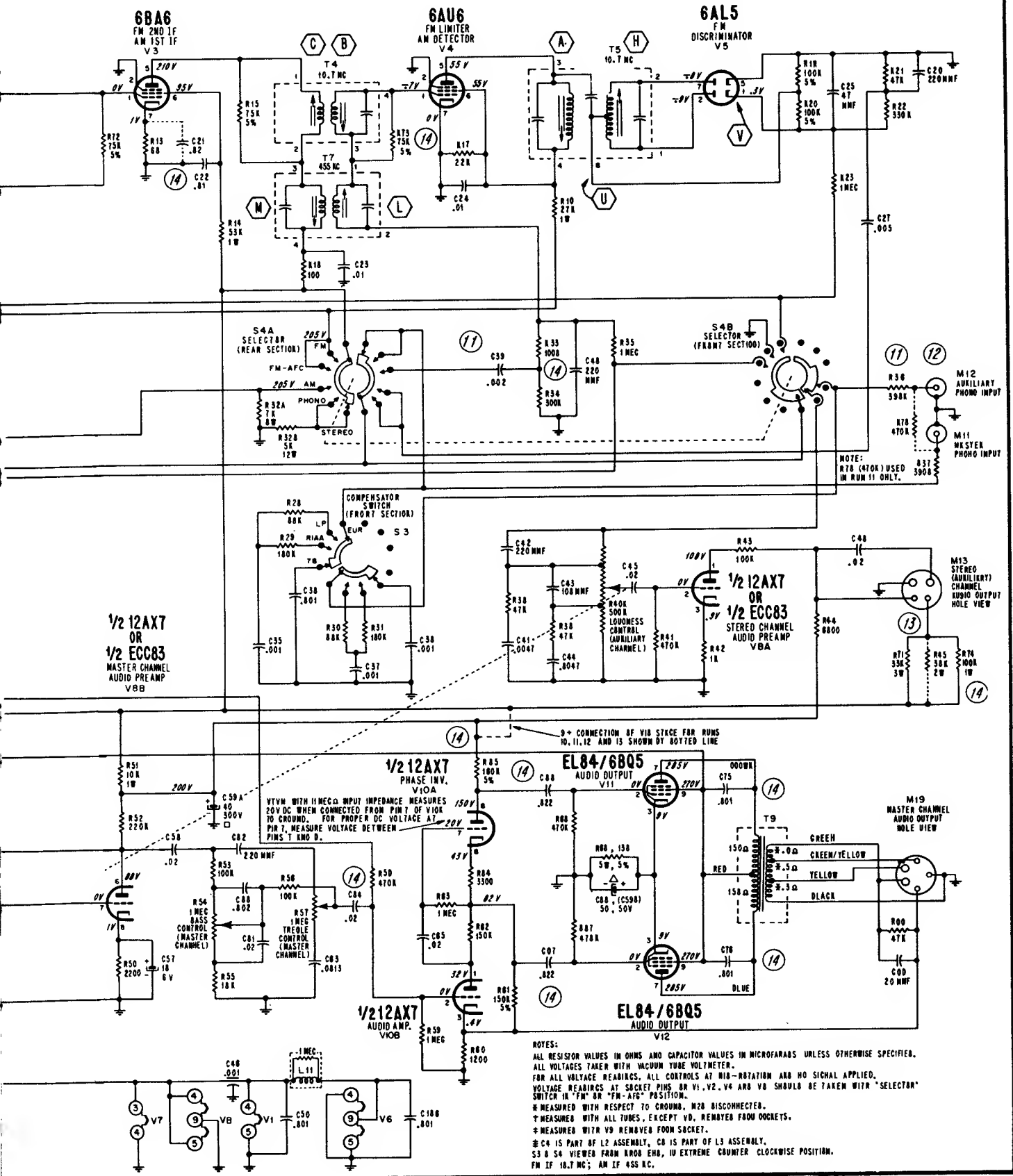

VOLUME R-19, MOST-OFTEN-NEEDED 1959 RADIO SERVICING INFORMATION

ARVIN
 Model 2585
 Chassis 1.45000

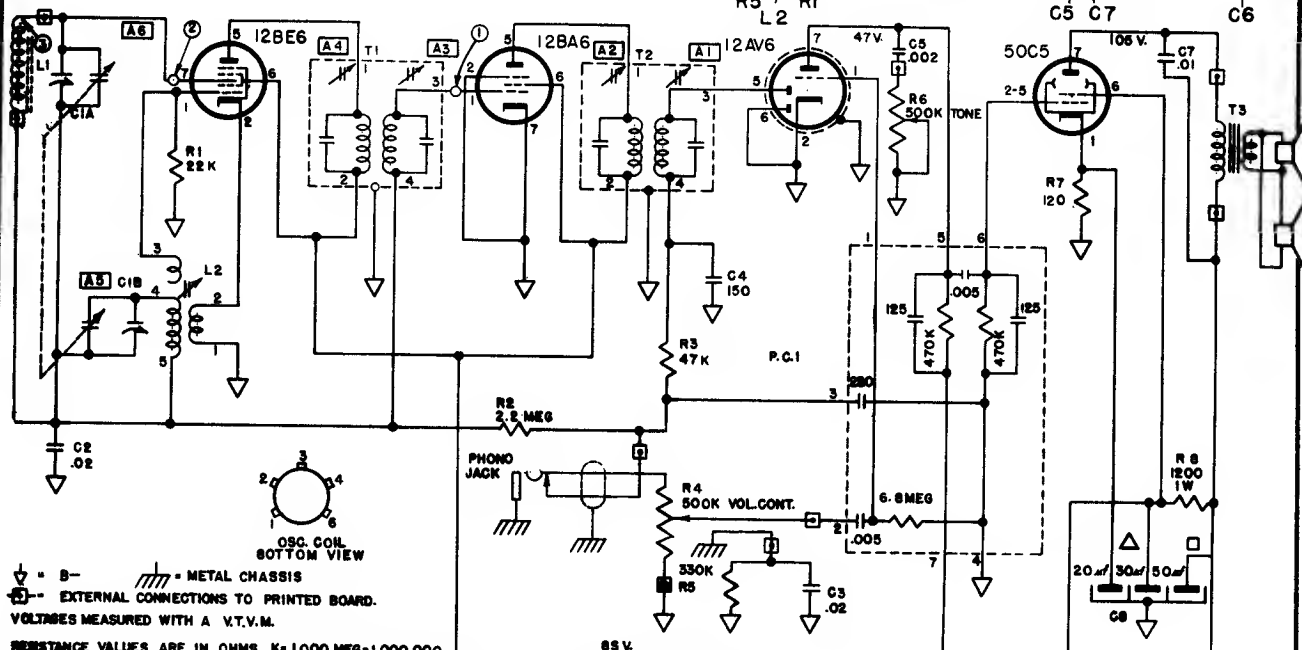
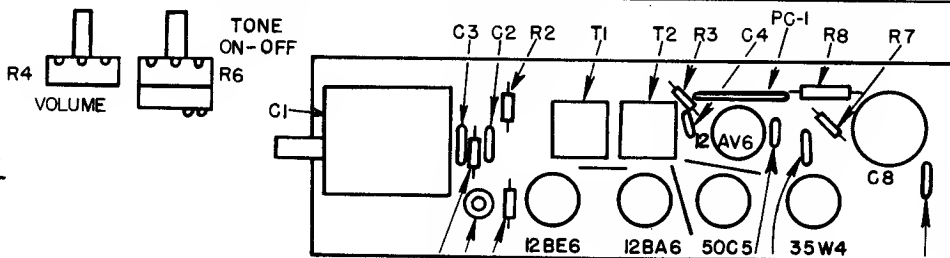

↓ = B- METAL CHASSIS
 ⊕ = EXTERNAL CONNECTIONS TO PRINTED BOARD.
 VOLTS MEASURED WITH A V.T.V.M.

RESISTANCE VALUES ARE IN OHMS K=1,000, MEG=1,000,000
 CAPACITANCE VALUES LESS THAN (1) ARE IN MICROFARADS (μF),
 AND VALUES OF (1) OR GREATER ARE IN MICROMICROFARADS (μμF), UNLESS OTHERWISE INDICATED.

CIRCUIT POINT	DUMMY TO GENERATOR	INPUT FOR .05 WATT OUTPUT (0.4 VOLTS ACROSS V.C.)	INPUT FOR .5 WATT OUTPUT (1.28 VOLTS ACROSS V.C.)
1	.05 μf AT 455 KC	2000 UV	5000 U VOLTS
2	.05 μf AT 455 KC	60	150
3	STANDARD LOOP AT 1000 KC	200 UV / M	500 UV / M

ALIGNMENT PROCEDURE

Output meter connection.....Across speaker voice coil
 Connection of generator ground lead..... Floating ground
 Position of Volume Control..... Fully clockwise

Position of Variable	Frequency of Generator	Dummy Antenna	Generator Output Connection	Trimmers Adjusted in Order Shown for Maximum Output	Functions of Trimmer
Open	455	.05 μf	Pin 7 12BE6	A1, A2, A3, A4	I. F.
Open	1670		* Test Loop	A5	Oscillator
1400	1400		* Test Loop	A6	Antenna
600	600		* Test Loop	Check Point	

* Standard Hazeltine Test Loop Model 1150 or 3 turns of wire about 6" in diameter placed about one foot from the set loop.

The alignment procedure should be repeated in the original order for greatest accuracy. Always keep the output from the signal generator at its lowest possible value to make the AVC action of the receiver ineffective.

MOST-OFTEN-NEEDED 1959 RADIO SERVICING INFORMATION

ARVIN
Model 2581
Chassis 1.43800

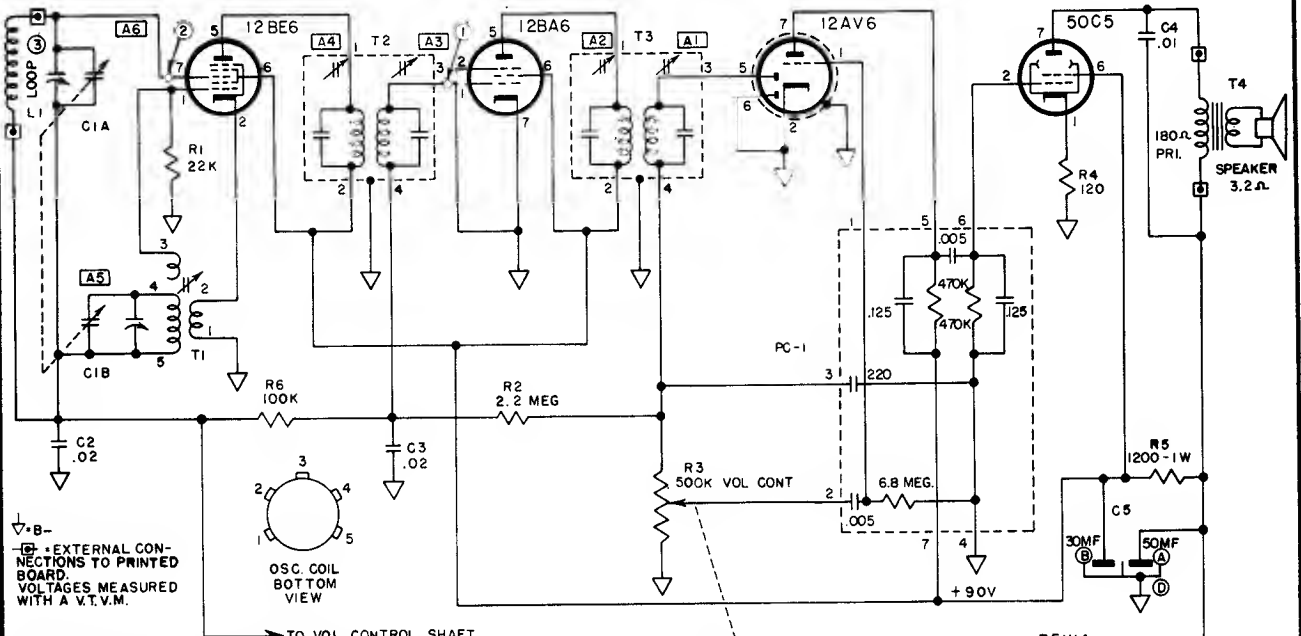
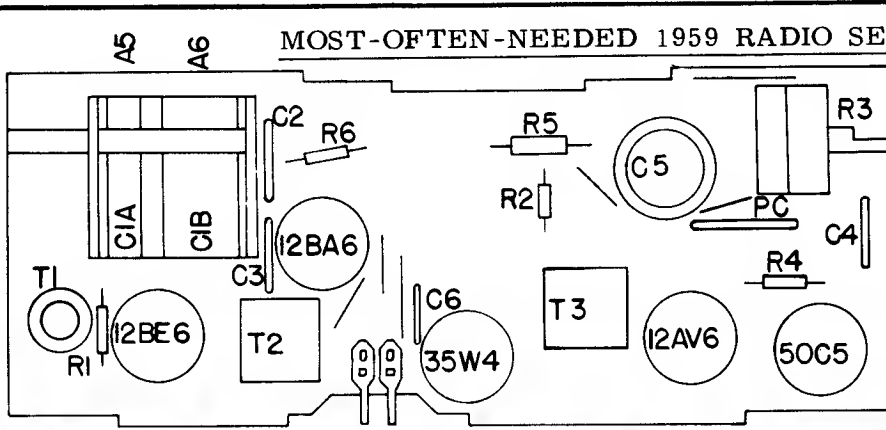

⊕ - EXTERNAL CONNECTIONS TO PRINTED BOARD. VOLTAGES MEASURED WITH A V.T.V.M.

RESISTANCE VALUES ARE IN OHMS K=1,000, MEG=1,000,000. CAPACITANCE VALUES LESS THAN (μ) ARE IN MICROFARADS (μF), AND VALUES OF (1) OR GREATER ARE IN MICROMICROFARADS (μμF), UNLESS OTHERWISE INDICATED.

APPROXIMATE SENSITIVITIES

CIRCUIT POINT	DUMMY TO GENERATOR	INPUT FOR 0.5 WATT OUTPUT (0.4 VOLTS ACROSS VC)	INPUT FOR 5 WATT OUTPUT (1.26 VOLTS ACROSS VC)
1	0.5 μf AT 455 KC	2000 UV	5000 UV
2	0.5 μf AT 455 KC	60	150
3	STANDARD LOOP AT 1000 KC	200 UV/M	500 UV/M

ALIGNMENT PROCEDURE Output meter connection Across speaker voice coil
 Output meter reading to indicate 500 milliwatts (standard output)... 1.26 volts
 Connection of generator ground lead..... Floating ground
 Generator modulation 30% 400 cycles

Position of Variable	Frequency of Generator	Dummy Antenna	Generator Output Connection	Trimmers Adjusted in Order Shown for Maximum Output	Function of Trimmer
Open	455 Kc	.05 μ fd	Pin 7 12BE6	A1, A2, A3, A4	I. F.
Open	1670 Kc		* Test Loop	A5	Oscillator
1400	1400 Kc		* Test Loop	A6	Antenna
1000	1000 Kc		* Test Loop	Fan C1A Plates	
600	600 Kc		* Test Loop	Fan C1A Plates	

* Standard Hazeltine Test Loop Model 1150 or 3 turns of wire about 6" in diameter placed about one foot from the set loop.

VOLUME R-19, MOST-OFTEN-NEEDED 1959 RADIO SERVICING INFORMATION

ARVIN Industries
 Model 3588
 Chassis 1.45200

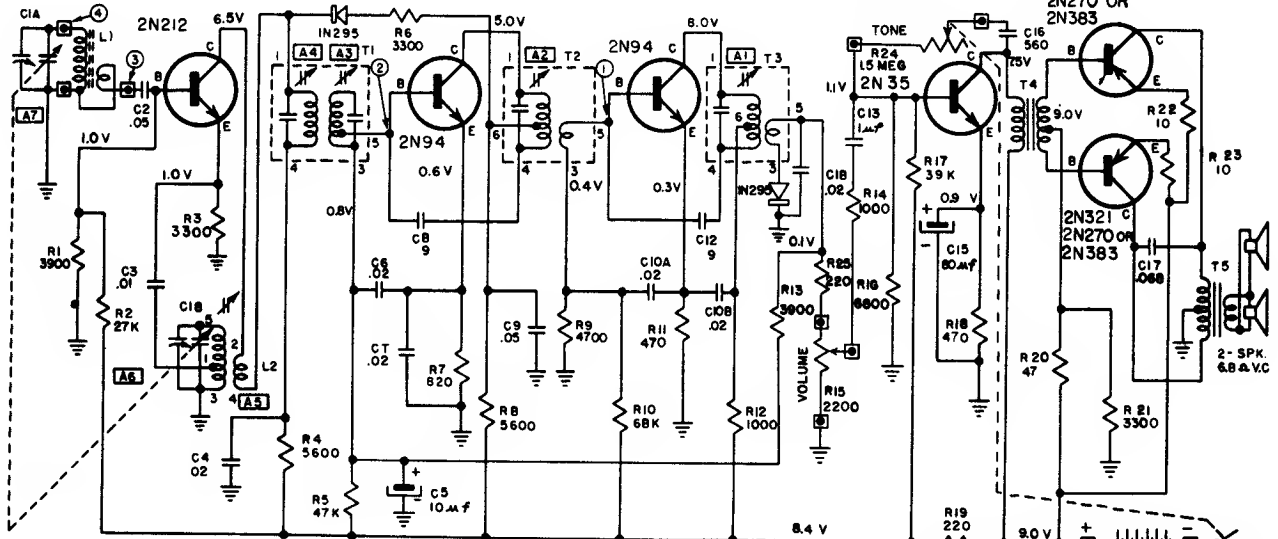
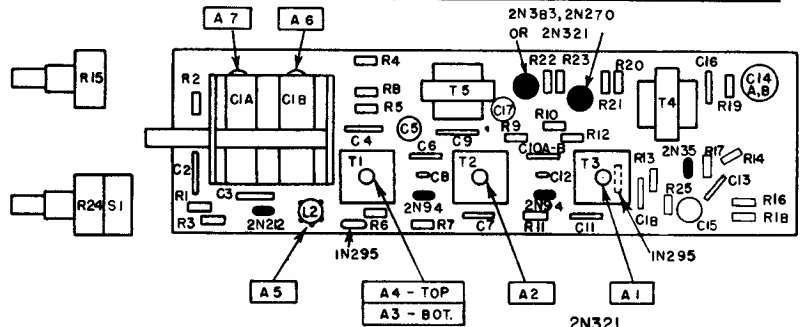

RESISTANCE VALUES ARE IN OHMS; K = 1000.

CAPACITANCE VALUES LESS THAN 1.0 ARE IN MICROFARADS (μmf) AND VALUES GREATER THAN 1.0 ARE IN MICRO-MICROFARADS ($\mu\text{m}\mu\text{f}$) EXCEPT WHERE NOTED.

VOLTAGE READINGS TO COMMON GROUND ARE MEASURED WITH VACUUM TUBE VOLT-METER UNDER NO SIGNAL CONDITIONS WITH TUNING CAPACITOR CLOSED AND VOLUME CONTROL AT MAXIMUM CLOCKWISE ROTATION.

SIGNAL TEST POINT	TEST FREQUENCY	SERIES CAPACITOR TO GENERATOR	INPUT FOR .05 WATT OUTPUT (0.4 V ACROSS 3.2 Ω)
①	455 KC	.05 μf	2000 μV
②	455 KC	.05 μf	65 μV
③	455 KC	.05 μf	5 μV
④	1000	STANDARD LOOP	150 $\mu\text{V}/\text{M}$

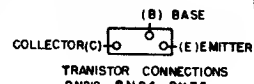
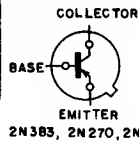

COMMON GROUND SYMBOL

EXTERNAL CONNECTION TO PRINTED CIRCUIT. COLOR OUT

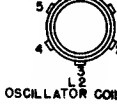

TRANSFORMER (BOTTOM VIEWS)

ALIGNMENT PROCEDURE

- Output meter reading to indicate 50 milliwatts 0.4V
- Output meter connection..... Across speaker voice coil
- Connection of generator ground lead..... Common Ground
- Generator Modulation..... 30% 400 cycles
- Position of volume control..... Fully clockwise

Position of Variable	Generator Frequency	Dummy Antenna	Generator Connections	Trimms Adj. in order shown for Max. Output	Function of Trimmer
Open	455 Kc	.05 μf	C1A	A1 (Top of T3) A2 (Top of T2) A3 (Bottom of T1) A4 (Top of T1)	I. F. I. F. I. F. I. F.
Open	1670 Kc		*Test Loop	A6	Oscillator
1400 Kc	1400 Kc		*Test Loop	A7	Antenna
600 Kc	600 Kc		*Test Loop	Check Point	

*Standard Hazeltine Test Loop Model 1150 or 3 turns of wire about 6" in diameter placed about one foot from the set loop.

VOLUME R-19, MOST-OFTEN-NEEDED 1959 RADIO SERVICING INFORMATION

ARVIN Industries
 Model 5583, Chassis 1.44200
 Model 2584, Chassis 1.44100
 differs from this material by
 not using a clock timer and in
 employing two speakers.

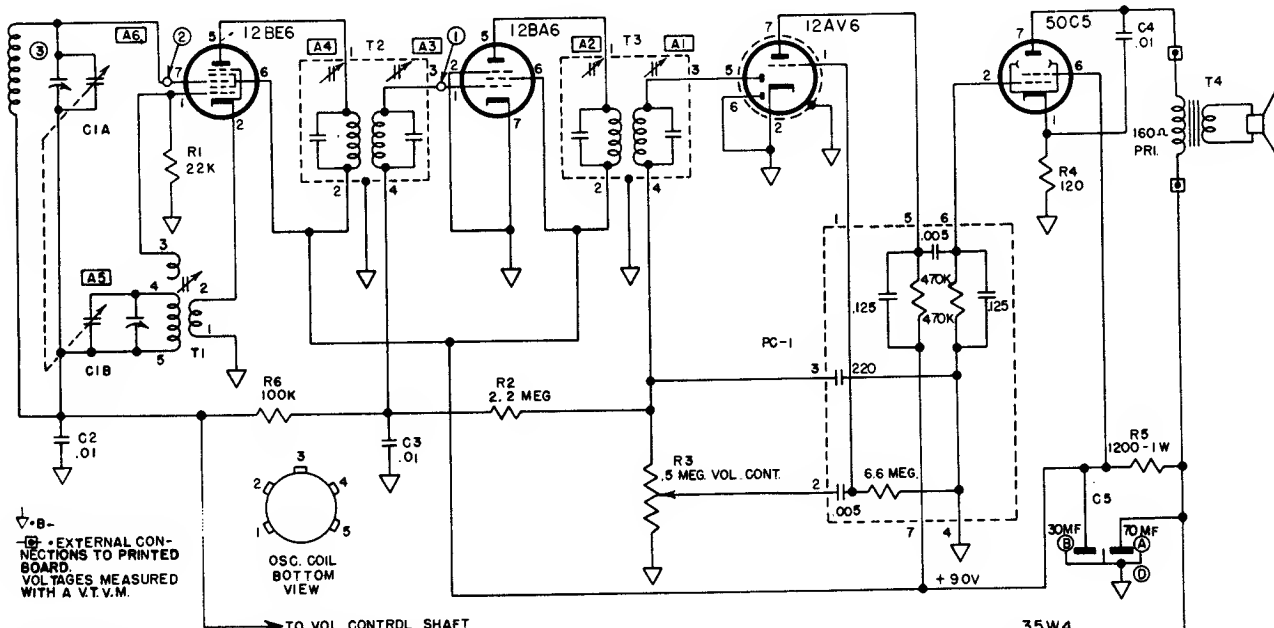
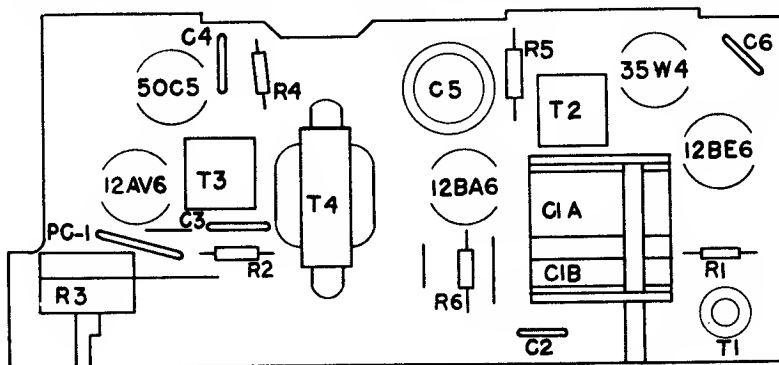

↓ B -
 EXTERNAL CONNECTIONS TO PRINTED BOARD.
 VOLTAGES MEASURED WITH A V.T.V.M.

RESISTANCE VALUES ARE IN OHMS K=1,000, MEG=1,000,000.
 CAPACITANCE VALUES LESS THAN (1) ARE IN MICROFARADS (μF),
 AND VALUES OF (1) OR GREATER ARE IN MICROMICROFARADS (μμF), UNLESS OTHERWISE INDICATED.

APPROXIMATE SENSITIVITIES

CIRCUIT POINT	DUMMY TD GENERATOR	INPUT FOR .05 WATT OUTPUT (0.4 VOLTS ACROSS VC)	INPUT FOR .5 WATT OUTPUT (1.26 VOLTS ACROSS VC)
1	.05 μF AT 455 KC	2000 UV	5000 UV
2	.05 μF AT 455 KC	60	150
3	STANDARD LOOP AT 1000 KC	200UV/M	500 UV/M

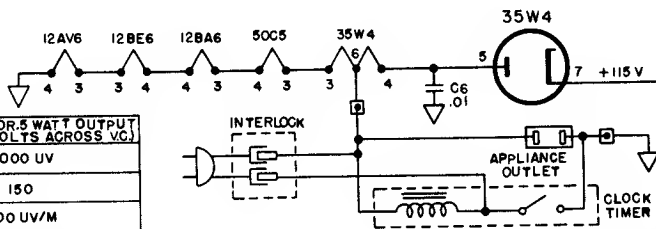

ALIGNMENT PROCEDURE Output meter connection Across speaker voice coil
 Output meter reading to indicate 500 milliwatts (standard output)... 1.26 volts
 Connection of generator ground lead..... Floating ground
 Generator modulation 30% 400 cycles

Position of Variable	Frequency of Generator	Dummy Antenna	Generator Output Connection	Trimmers Adjusted in Order Shown for Maximum Output	Function of Trimmer
Open	455 Kc	.05 μ fd	Pin 7 12BE6	A1, A2, A3, A4	I. F. Oscillator Antenna
Open	1670 Kc		* Test Loop	A5	
1400	1400 Kc		* Test Loop	A6	
1000	1000 Kc		* Test Loop	Fan C1A Plates	
600	600 Kc		* Test Loop	Fan C1A Plates	

* Standard Hazeltine Test Loop Model 1150 or 3 turns of wire about 6" in diameter placed about one foot from the set loop.

VOLUME R-19, MOST-OFTEN-NEEDED 1959 RADIO SERVICING INFORMATION

ARVIN Industries

Model 8584, Chassis 1.44600

SIGNAL TEST POINT	TEST FREQUENCY	SERIES CAPACITOR TO GENERATOR	INPUT FOR .05 WATT OUTPUT (0.4 V ACROSS 3.2Ω)
①	455 KC	.05 μf	5000 μV
②	455 KC	.05 μf	200 μV
③	455 KC	.05 μf	8 μV
④	1000 KC	STANDARD LOOP	250 μV/M

ALIGNMENT PROCEDURE

Output meter reading to indicate 50 milliwatts 0.4V
 Output meter connection Across speaker voice coil
 Connection of generator ground lead Common Ground
 Generator Modulation 30% 400 Cycles
 Position of volume control Fully Clockwise

Position of Variable	Generator Frequency	Dummy Antenna	Generator Connections	Trimmers Adj. in order shown for Max. Output	Function of Trimmer
Open	455 Kc	.05 μf	C1A	A1 (Top of T3) A2 (Top of T2) A3 (Top of T1) A4	I. F. I. F. I. F. Oscillator
Open	1670 Kc		*Test Loop	A6	Antenna
1400 Kc	1400 Kc		*Test Loop	Check Point	
600 Kc	600 Kc		*Test Loop		

*Standard Hazeltine Test Loop Model 1150 or 3 turns of wire about 6" in diameter placed about one foot from the set loop.

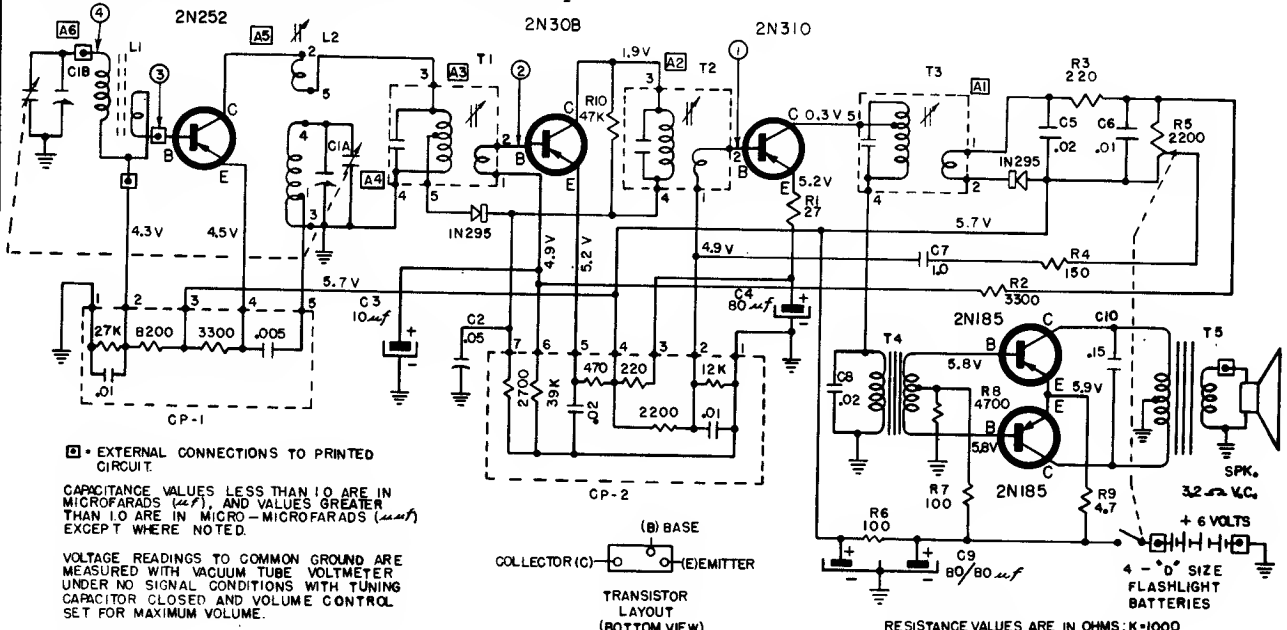

□ = EXTERNAL CONNECTIONS TO PRINTED CIRCUIT.
 CAPACITANCE VALUES LESS THAN 1.0 ARE IN MICROFARADS (μf), AND VALUES GREATER THAN 1.0 ARE IN MICRO-MICROFARADS (μμf) EXCEPT WHERE NOTED.
 VOLTAGE READINGS TO COMMON GROUND ARE MEASURED WITH VACUUM TUBE VOLTMETER UNDER NO SIGNAL CONDITIONS WITH TUNING CAPACITOR CLOSED AND VOLUME CONTROL SET FOR MAXIMUM VOLUME.

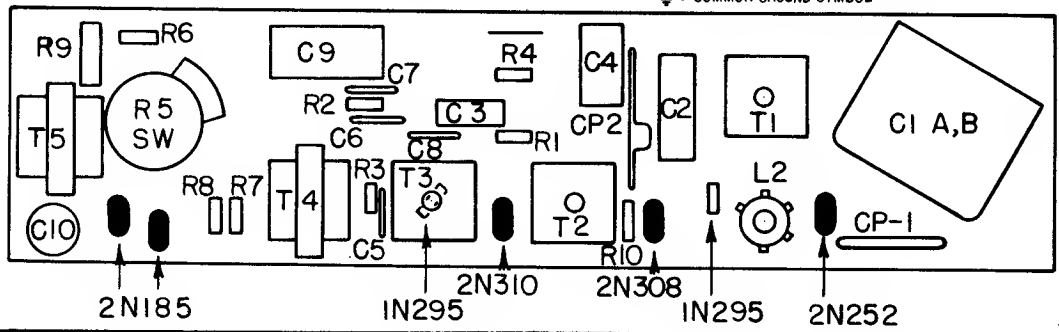
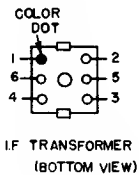
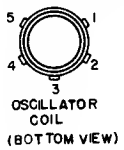

VOLUME R-19, MOST-OFTEN-NEEDED 1959 RADIO SERVICING INFORMATION

ARVIN Industries, Models 8581, 8583, Chassis 1.43700, 1.43900

ALIGNMENT PROCEDURE

Output meter reading to indicate .05 watt across voice coil 0.4V
 Generator ground lead connected floating ground
 Generator modulation 30% 400 cycles
 Position of Volume Control fully on

Position of Variable	Generator Frequency	Dummy Antenna	Generator Connections	Adjust Trimmers (In order shown)	Function of Trimmer
Open	455 Kc	.05 μf	Mixer Grid	A1, A2, A3,	I. F.
Open	1670 Kc		Test Loop	A4	Oscillator
1400 Kc	1400 Kc		Test Loop	A5	Antenna
600 Kc	600 Kc		Test Loop	Check Point	

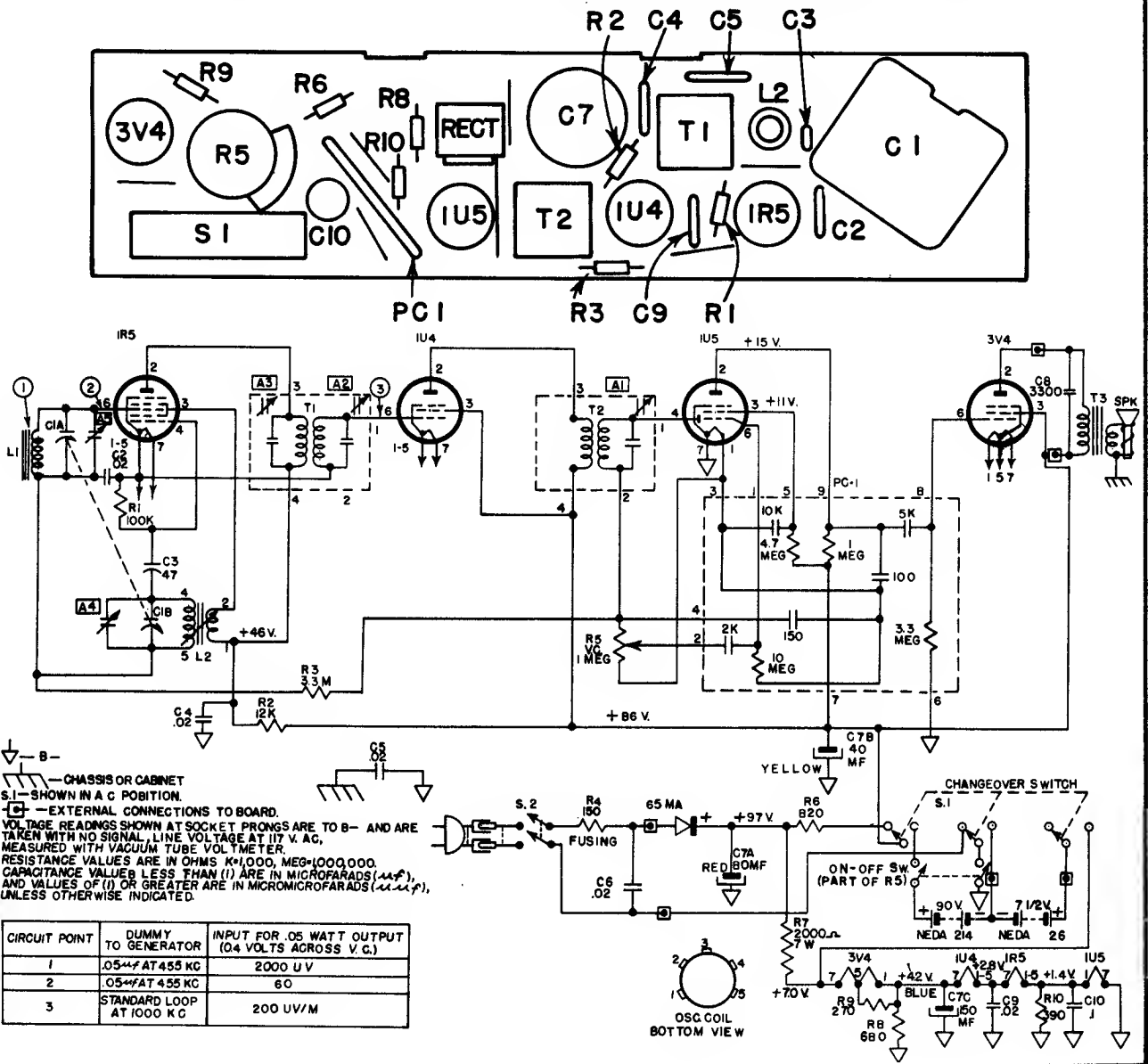

DELCO

BUICK 981968
(Continued from preceding page)

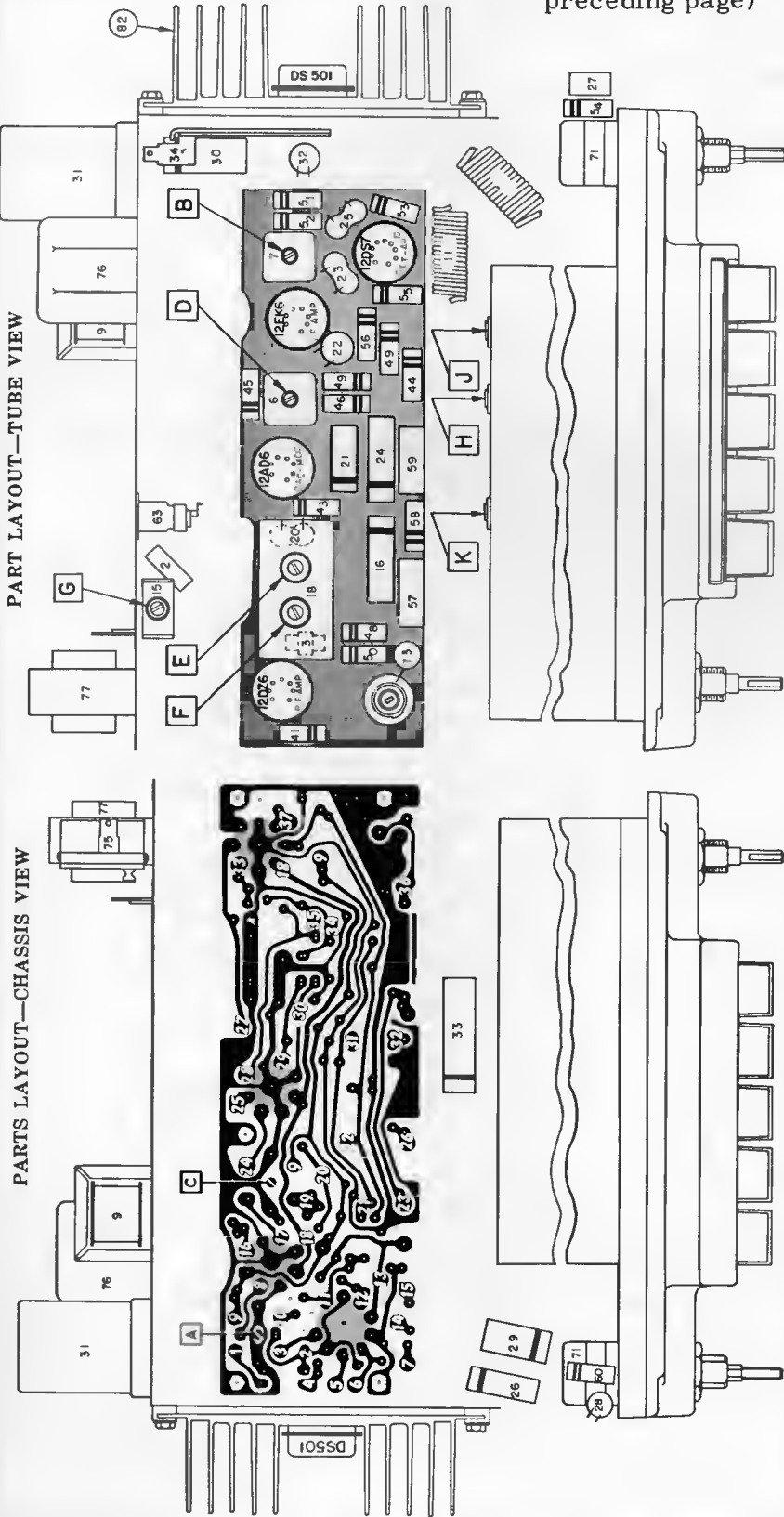

WHITE NUMBERS ON PRINTED CIRCUIT BOARD DRAWING CORRESPOND TO NUMBERS ENCIRCLED ON SCHEMATIC.

STEP	SERIES CONDENSER OR DUMMY ANTENNA	CONNECT SIGNAL GENERATOR TO	SIGNAL GENERATOR FREQUENCY	TUNE RECEIVER TO	ADJUST IN SEQUENCE FOR MAX. OUTPUT
1	0.1 Mfd.	12DA6 Grid (Pin #7)	262 KC	High Frequency Stop	A, B, D, C
2	.000082 Mfd.	Antenna Connector	1615 KC	High Frequency Stop	*E, F, G
3	.000082 Mfd.	Antenna Connector	600 KC	Signal Generator Signal	J, K
4	.000082 Mfd.	Antenna Connector	1615 KC	High Frequency Stop	F, G
5	.000082 Mfd.	Antenna Connector	900 KC	Signal Generator Signal	L**

ALIGNMENT PROCEDURE

- Output Meter Connections.....Across Voice Coil
- Generator Return.....To Receiver Chassis
- Dummy Antenna.....In Series With Generator
- Volume Control Position.....Maximum Volume
- Tone Control Position.....Treble
- Generator Output...Minimum for Readable Indication

*Before making this adjustment check mechanical setting of oscillator core "H." The rear of the core should be 1/8" from the mounting end of the coil form. (This measurement is readily made by inserting a suitable plug in the mounting end of the coil form.) Core adjustment should be made with a non-metallic screwdriver.

**L is the pointer adjustment screw which is on the connecting link, between the pointer assembly and the parallel guide bar. It should be adjusted so that the dial pointer corresponds with the 900 KC mark on the dial.



BUICK 981970
 OLDSMOBILE 989172
 PONTIAC 988978

Continued on the next page,
 adjacent at right.

SCHEMATIC DATA

Voltages measured terminal to chassis with a VTVM—no signal. The portable unit voltages are taken with a battery voltage of 5.2 volts. Rack unit voltages taken with 12 volts at Illus. 37.

Total "A" Drain in Car 1.3 amps.
 Total "A" Drain of Portable 6 ma.
 Tolerance on Voltage $\pm 10\%$.

Resistances are $\pm 20\%$. Ohmmeter reading in transistor circuits are affected by meter battery polarity. Check in both directions and use highest reading.

*—Before measuring transistor voltages, the shorting type speaker socket must be opened and a 4 ohm speaker connected. If transistor is replaced, adjust bias potentiometer (Illus. 84) to obtain proper collector voltage with 12 volts input to radio.

**—Illus. 77 is a fuse resistor for the DS 501 transistor. An open fuse resistor will cause 0 volts at transistor collector.

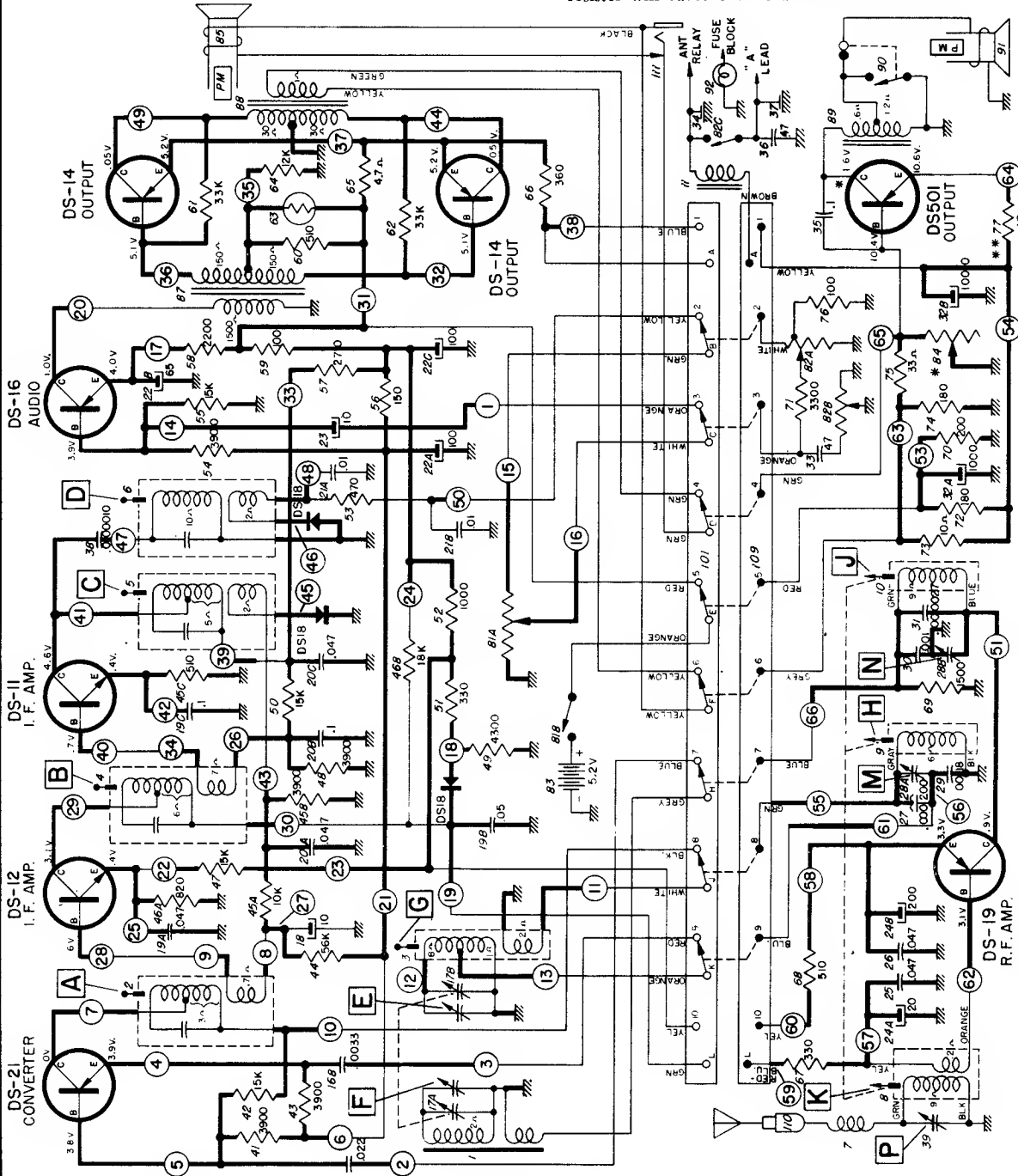

Isolate trouble to portable section or car unit by pulling portable section out of car.

- A. If it fails to operate as a portable, trouble is in portable unit.
- B. If it operates as a portable but not in the car, trouble is in car unit or car antenna.
- C. If it operates in car but not as a portable, check batteries, portable antenna and interconnecting sockets.

VOLUME R-19, MOST-OFTEN-NEEDED 1959 RADIO SERVICING INFORMATION

DELCO
 BUICK 981970
 OLDSMOBILE 989172
 PONTIAC 988978

(Continued)

NOTE: WHITE NUMBERS ON PRINTED CIRCUIT DRAWINGS CORRESPOND TO ENCIRCLED NUMBERS ON SCHEMATIC DIAGRAM.

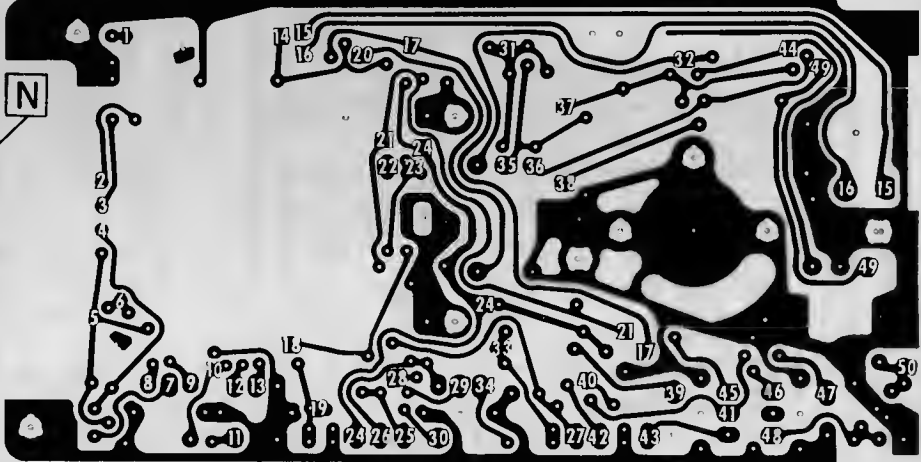
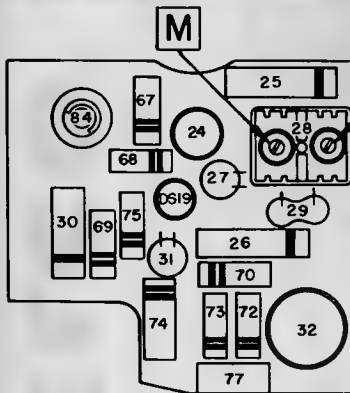
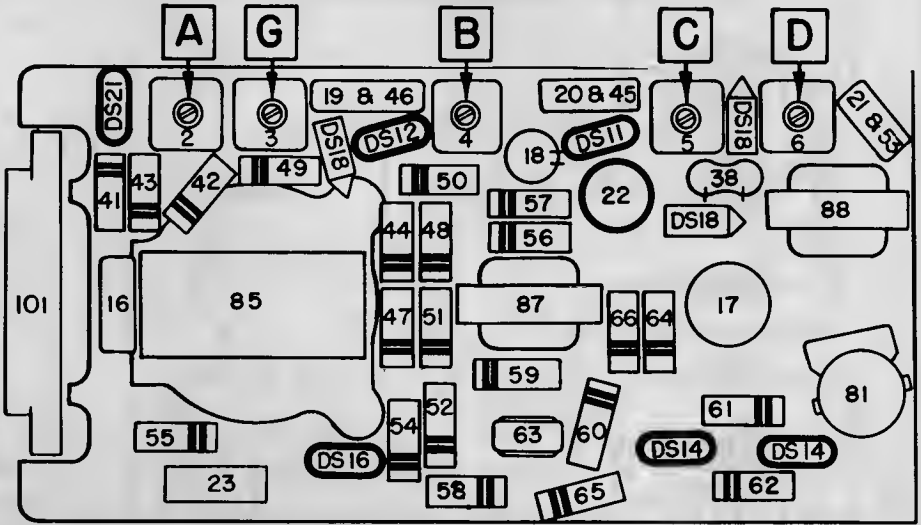
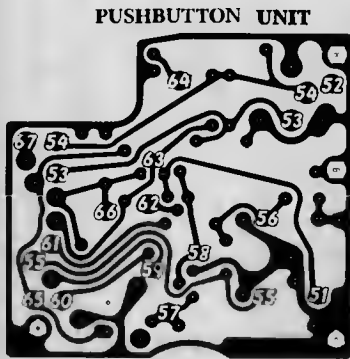

ALIGNMENT

Set radio volume control to maximum. Read output at speaker; keep below .5 volt.

Step	Method Of Connecting Generator	Connect Generator To	Signal Frequency	Tune Receiver To	Adjust In Sequence For Max. Output
1	Thru .1 mfd. Cap.	Converter Base (Island 5)	465 KC	High freq. stop	A, B, C, D
2	Pick up loop	By induction to antenna	1680 KC	High freq. stop	E Trimmer on variable (nearest batteries)
3	Do not use	Align on noise (Lights, razor, etc.)	Noise	Near 600 KC	G
4	Pick up loop	By induction to antenna	1400 KC	Signal Gen. freq.	F
If it is necessary to align pushbutton tuner, connect portable to it and follow the steps below.					
5	.000068 mfd., Cap.	Antenna connector	1615 KC	High freq. stop	*M, N, P
6	.000068 mfd., Cap.	Antenna connector	600 KC	Signal Gen. freq.	J, K
7	.000068 mfd., Cap.	Antenna connector	1615 KC	Signal Gen. freq.	N, P
8	.000068 mfd., Cap.	Antenna connector	1000 KC	Signal Gen. freq.	L**

*Before making this adjustment, check mechanical setting of oscillator core "H," with radio tuned to high frequency limit. The rear of the core should be 1/8" from the mounting end of the coil form. (This measurement is readily made by inserting a ruled plug in the rear of the coil form.)

**L is the pointer adjustment screw which is on the connecting link, between the pointer assembly and the parallel guide bar. It should be adjusted so that the dial pointer corresponds with the 1100 KC mark on the dial.

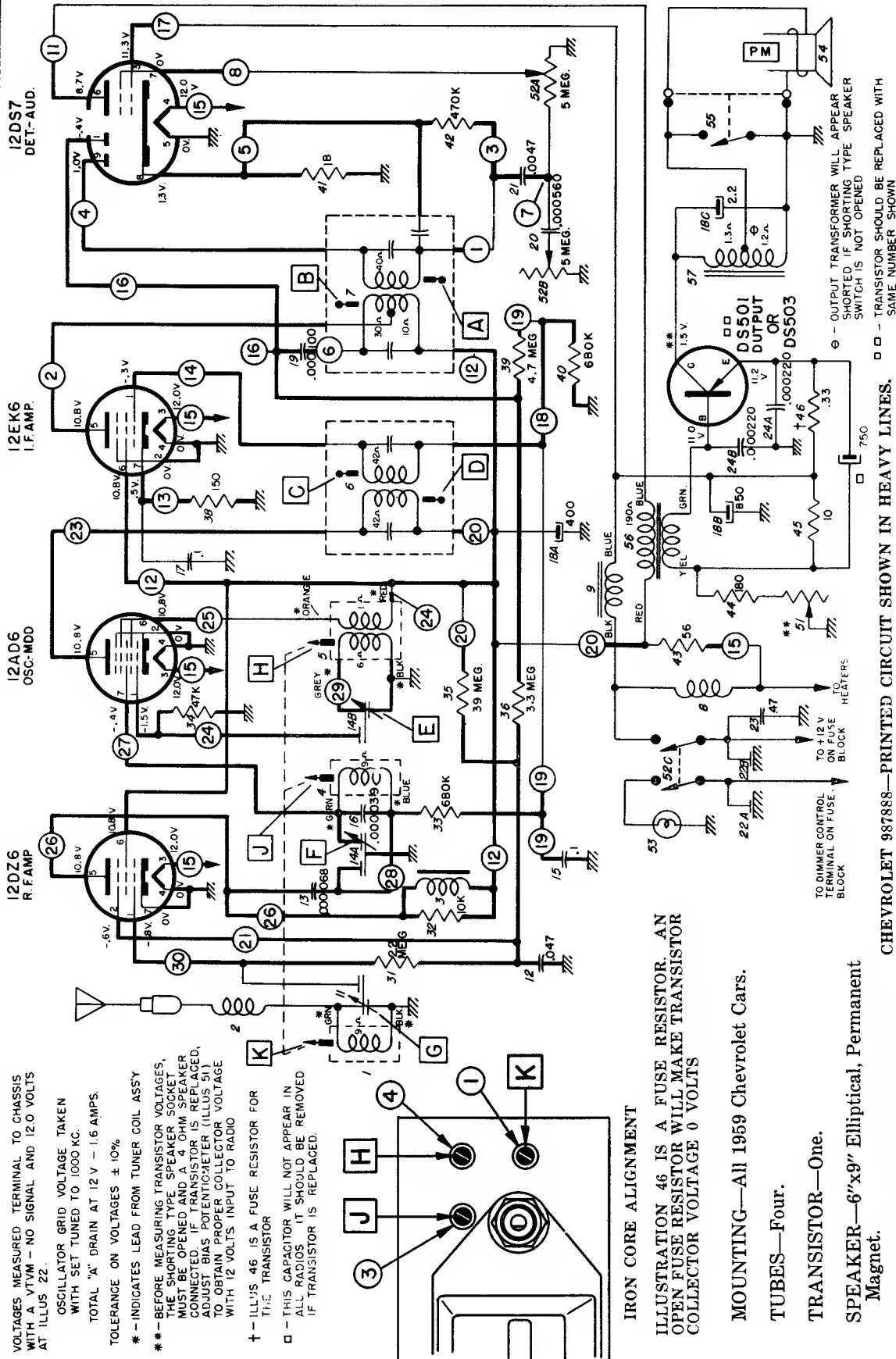

VOLTAGES MEASURED TERMINAL TO CHASSIS WITH A VTVM - NO SIGNAL AND 12.0 VOLTS AT ILLUS 22.

OSCILLATOR GRID VOLTAGE TAKEN WITH SET TUNED TO 1000 KC. TOTAL "A" DRAIN AT 12 V - 1.6 AMPS. TOLERANCE ON VOLTAGES ± 10%.

* - INDICATES LEAD FROM TUNER COIL ASSY. ** - BEFORE MEASURING TRANSISTOR VOLTAGES, THE SHORTING TYPE SPEAKER SHORTER MUST BE OPENED. TRANSISTOR OHM READER, ADJUST BIAS POTENTIOMETER (ILLUS 5A) TO OBTAIN PROPER COLLECTOR VOLTAGE WITH 12 VOLTS INPUT TO RADIO.

† - ILLUS 46 IS A FUSE RESISTOR FOR THE TRANSISTOR. □ - THIS CAPACITOR WILL NOT APPEAR IN ALL RADIOS. IT SHOULD BE REMOVED IF TRANSISTOR IS REPLACED.

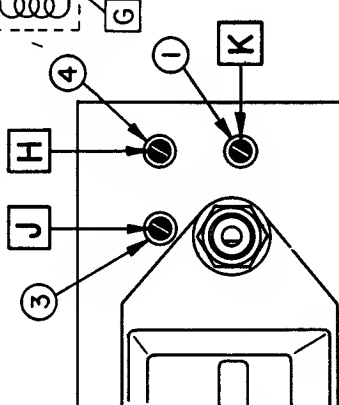

IRON CORE ALIGNMENT

ILLUSTRATION 46 IS A FUSE RESISTOR. AN OPEN FUSE RESISTOR WILL MAKE TRANSISTOR COLLECTOR VOLTAGE 0 VOLTS

MOUNTING—All 1959 Chevrolet Cars.

TUBES—Four.

TRANSISTOR—One.

SPEAKER—6"x9" Elliptical, Permanent Magnet.

ANTENNA TRIMMER COMPENSATION—for Antennas Between 0.000050 - .000100 Mfd.

TUNING RANGE—540-1600 KC.

CHEVROLET 987888—PRINTED CIRCUIT SHOWN IN HEAVY LINES.

DELCO

CHEVROLET MODEL 987888

(See next page for additional material)

⊖ - OUTPUT TRANSFORMER WILL APPEAR SHORTED IF SHORTING TYPE SPEAKER SWITCH IS NOT OPENED
 □ □ - TRANSISTOR SHOULD BE REPLACED WITH SAME NUMBER SHOWN

TO DIMMER CONTROL TERMINAL ON FUSE BLOCK
 TO +12V BATTERY

DELCO CHEVROLET MODEL 987888
(Continued from preceding page at left)

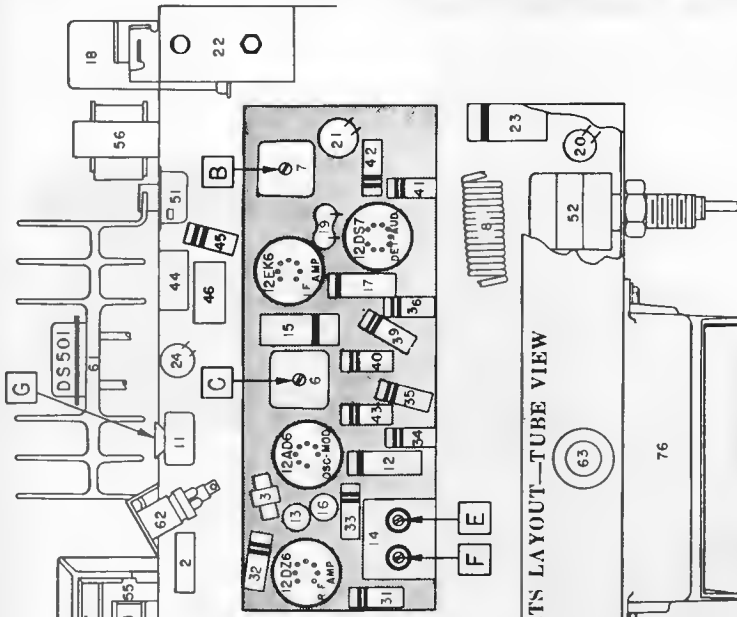

SOME RADIOS USE A DS 503 TRANSISTOR.
IT SHOULD BE REPLACED WITH A DS 503.

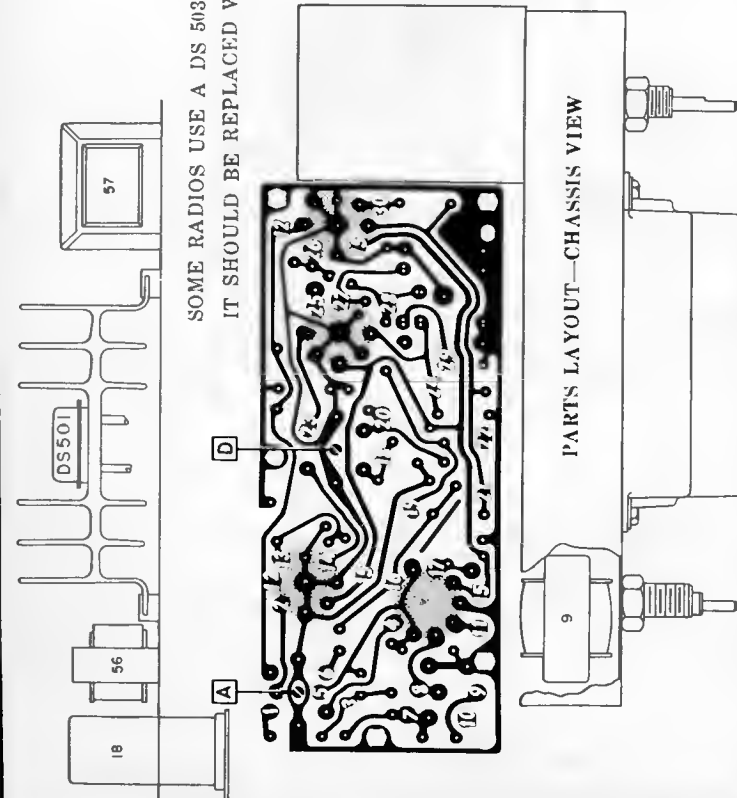

NUMBERS ON PRINTED CIRCUIT BOARD CORRESPOND WITH NUMBERS IN CIRCLES ON SCHEMATIC DIAGRAM.
CONNECT A. C. VOLTMETER ACROSS SPEAKER VOICE COIL DURING ALIGNMENT.

Output Meter Connections.....Across Voice Coil
Generator Return.....To Receiver Chassis
Dummy Antenna.....In Series With Generator
Volume Control Position.....Maximum Volume
Tone Control Position.....Treble Position
Generator Output.....Minimum for Readable Indication



CHEVROLET MODEL 987888
(Continued)

ALIGNMENT PROCEDURE

STEPS	SERIES CAPACITOR OR DUMMY ANTENNA	CONNECT SIGNAL GENERATOR TO	SIGNAL GENERATOR FREQUENCY	TUNE RECEIVER TO	ADJUST IN SEQUENCE FOR MAX. OUTPUT
1	0.1 Mfd.	12AD6 Grid (Pin #7)	262 KC	High Frequency Stop	A, B, C, D,
2	0.000082 Mfd.	Antenna Connector	1615 KC	High Frequency Stop	*E, F, G,
3	0.000082 Mfd.	Antenna Connector	600 KC	Signal Generator Signal	J, K
4	0.000082 Mfd.	Antenna Connector	1615 KC	High Frequency Stop	F, G

*Before making this adjustment check mechanical setting of oscillator core "H." The rear of the core should be 1 1/2" from the mounting end of the coil form. (This measurement is readily made by inserting a suitable plug in the mounting end of the coil form.) Core adjustment should be made with a non-metallic screw driver.
With the radio installed and the car antenna plugged in adjust the antenna trimmer "G" for maximum volume with the radio tuned to a weak station between 600 and 1000 KC (see sticker on case.)

DELCO

CHEVROLET MODEL 987891

(For additional material see the next page adjacent at right)

GENERAL

MOUNTING—All 1959 Chevrolet Cars.

TUNING—Manual and 5 P. B. Mechanical.

ANTENNA TRIMMER COMPENSATION—for Antennas Between 0.000050 - .000100 Mfd.

TUNING RANGE—540-1600 KC.

PUSH BUTTON SETUP PROCEDURE

Pull Push Button out. Tune in desired station manually. Push button all the way in.

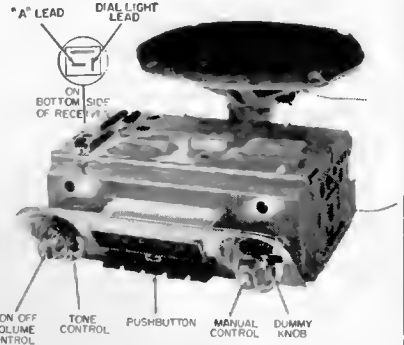

VOLTAGES MEASURED TERMINAL TO CHASSIS WITH A VTVM—NO SIGNAL AND 12.0 VOLTS AT ILLUS 29

OSCILLATOR GRID VOLTAGE TAKEN WITH SET TUNED TO 1000 KC.

TOTAL "A" DRAIN AT 12 V - 2.2 AMPS.

TOLERANCE ON VOLTAGES ±10%

- * — INDICATES LEAD FROM TUNER COIL ASS'Y
- ** — BEFORE MEASURING TRANSISTOR VOLTAGES, THE SHORTING TYPE SPEAKER SOCKET MUST BE OPENED AND A 4 OHM SPEAKER CONNECTED IF TRANSISTOR IS REPLACED. ADJUST BIAS POTENTIOMETER (ILLUS 73) TO OBTAIN PROPER COLLECTOR VOLTAGE WITH 12 VOLTS INPUT TO RADIO

† — ILLUS 60 IS A FUSE RESISTOR FOR THE TRANSISTOR

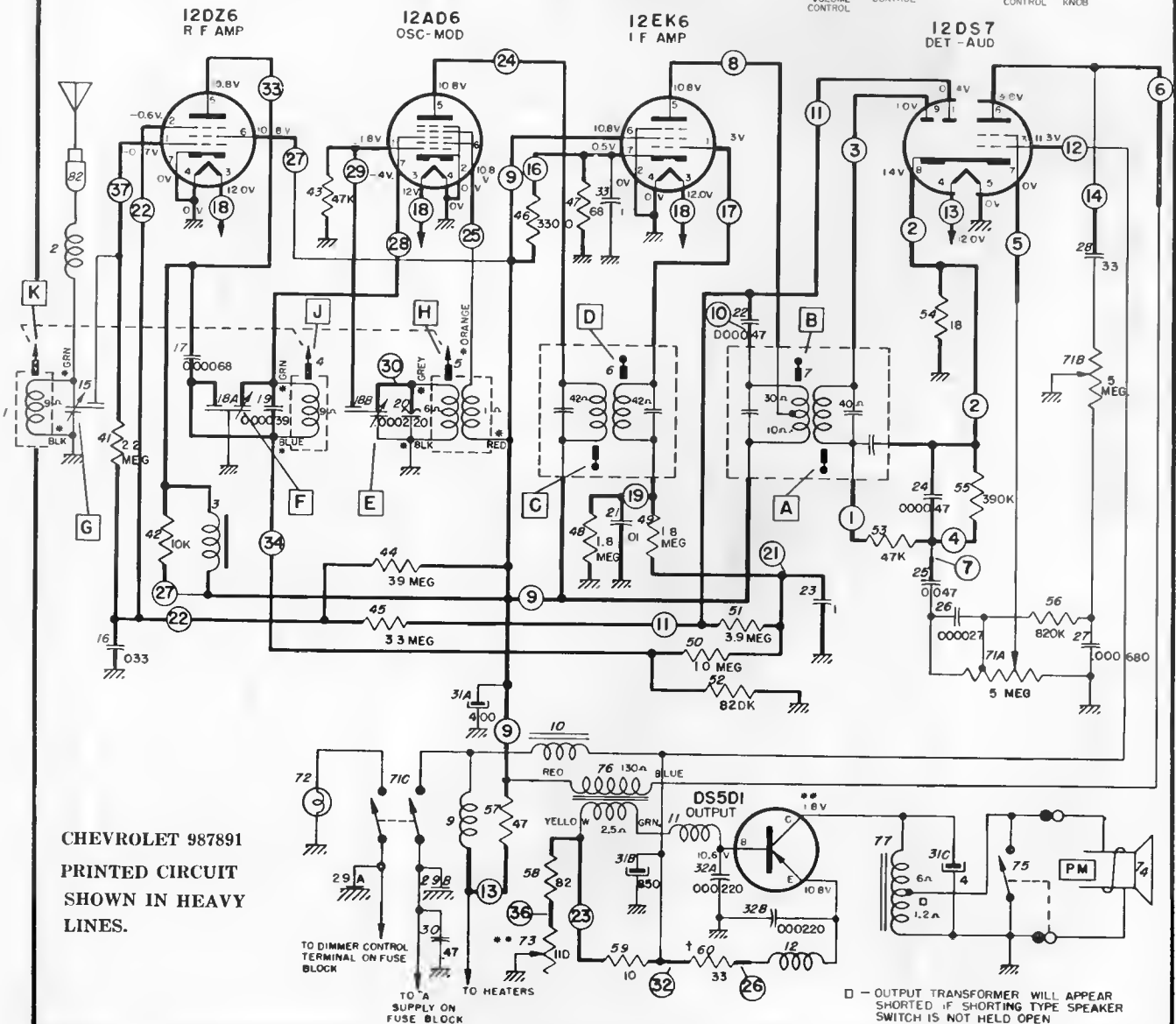

**CHEVROLET 987891
PRINTED CIRCUIT
SHOWN IN HEAVY
LINES.**

□ — OUTPUT TRANSFORMER WILL APPEAR SHORTED IF SHORTING TYPE SPEAKER SWITCH IS NOT HELD OPEN

DELCO

PONTIAC MODEL 988976
(Additional material on next page at right)

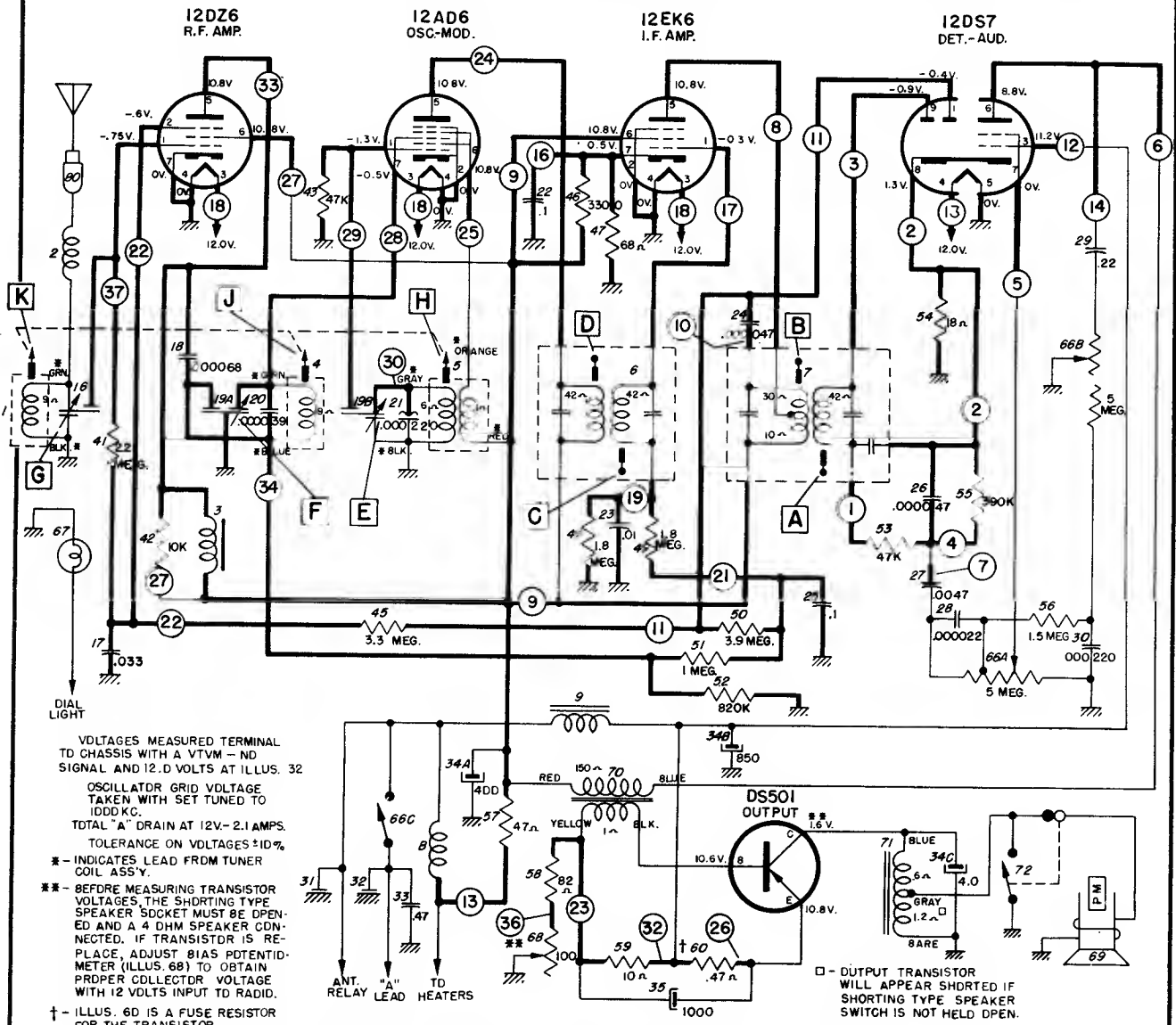

PONTIAC 988976—PRINTED CIRCUIT SHOWN IN HEAVY LINES.

ALIGNMENT PROCEDURE:

STEPS	SERIES CAPACITOR TO DUMMY ANTENNA	CONNECT SIGNAL GENERATOR TO	SIGNAL GENERATOR FREQUENCY	TUNE RECEIVER TO	ADJUST IN SEQUENCE FOR MAX. OUTPUT
1	0.1 Mfd.	12AD6 Grid (Pin #7)	262 KC	High Frequency Stop	A, B, C, D
2	0.000068 Mfd.	Antenna Connector	1615 KC	High Frequency Stop	*E, F, G
3	0.000068 Mfd.	Antenna Connector	600 KC	Signal Generator Signal	J, K
4	0.000068 Mfd.	Antenna Connector	1615 KC	High Frequency Stop	F, G
5	0.000068 Mfd.	Antenna Connector	1100 KC	Signal Generator Signal	L**

*Before making this adjustment check mechanical setting of oscillator core "H." The rear of the core should be 1 1/2" from the mounting end of the coil form. (This measurement is readily made by inserting a suitable plug in the mounting end of the coil form.) Core adjustment should be made with a non-metallic screwdriver.

**L is the pointer adjustment which is on the connecting link, between the pointer assembly and core guide bar (See tuner Dwg.). It should be adjusted so that when looking directly at the dial the pointer is on the 1100 KC mark. This setting is to give the correct relationship between the pointer and the dial when the radio is installed in a car.

DELCO

PONTIAC MODEL 988976

(Continued from preceding page at left)

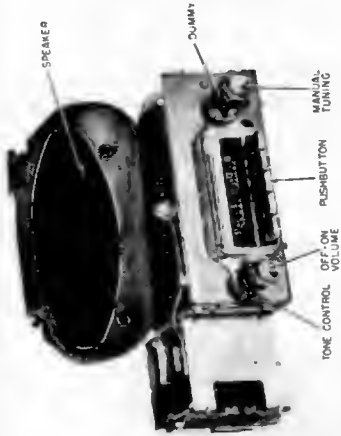

106

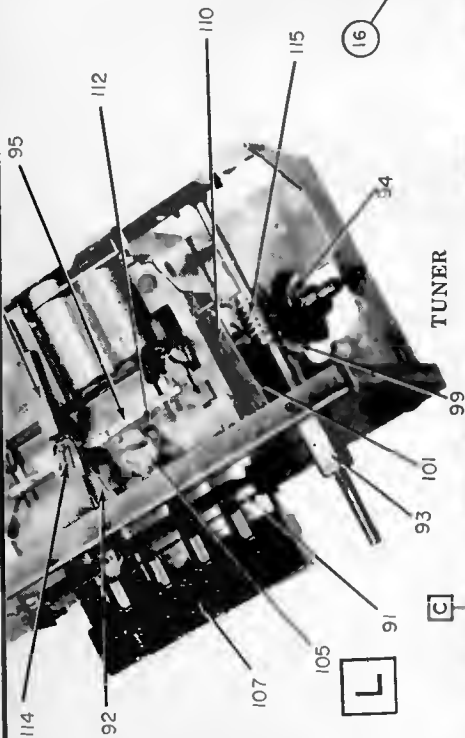

TUNER



PARTS LAYOUT—CHASSIS VIEW

CONNECT VACUUM TUBE VOLTMMETER ACROSS SPEAKER VOICE COIL DURING ALIGNMENT
 NUMBERS ON PRINTED CIRCUIT BOARD CORRESPOND WITH NUMBERS IN CIRCLES ON SCHEMATIC DIAGRAM.

IMPORTANT

THE SPEAKER SOCKET, MOUNTED ON OUTPUT TRANSFORMER, IS A SHORTING-TYPE AND MUST BE MECHANICALLY OPENED WHEN TESTING RADIO ON BENCH.

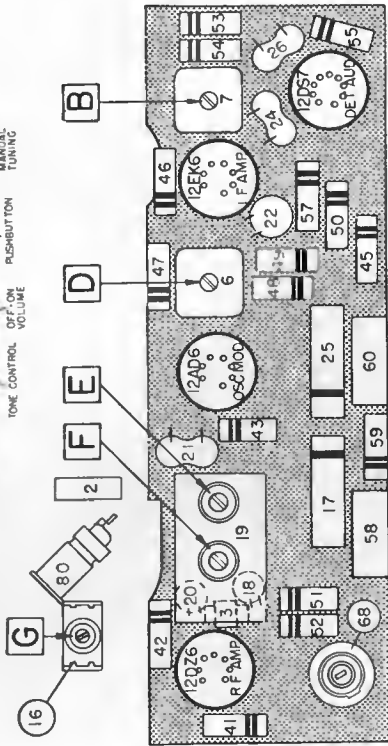

PARTS LAYOUT—TUBE VIEW

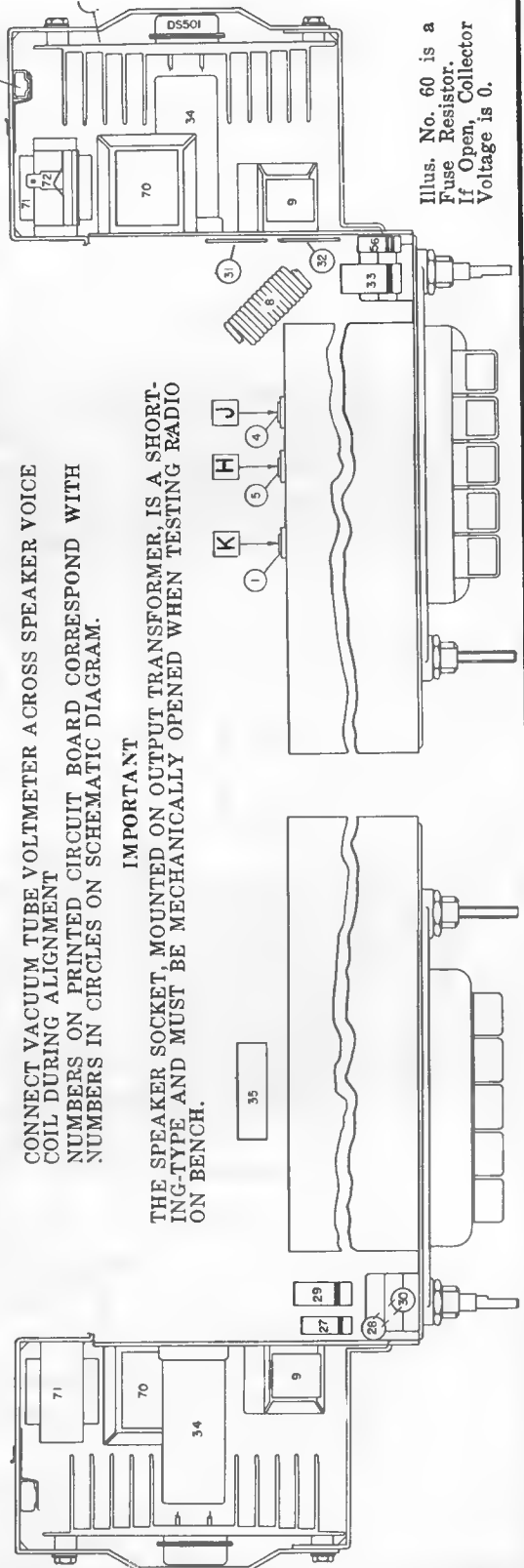

Illus. No. 60 is a Fuse Resistor. If Open, Collector Voltage is 0.

DELCO

OLDSMOBILE MODEL 989170

(Continued from preceding page)

ALIGNMENT PROCEDURE:

Output Meter Connections.....Across Voice Coil
 Generator Return.....To Receiver Chassis
 Dummy Antenna.....In Series With Generator
 Volume Control Position.....Maximum Volume
 Tone Control Position.....Treble Position
 Generator Output.....Minimum for Readable Indication

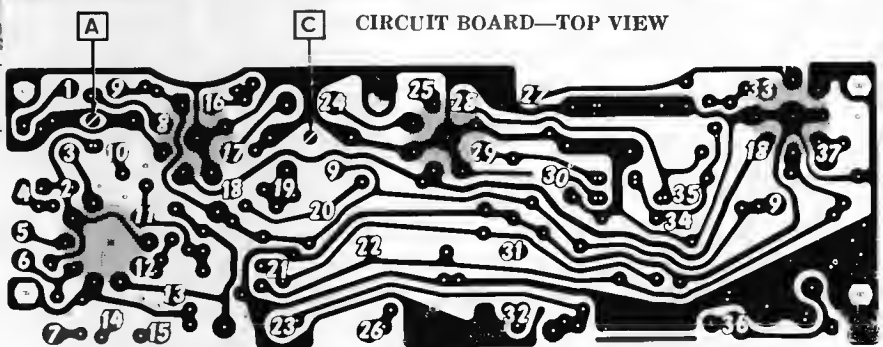
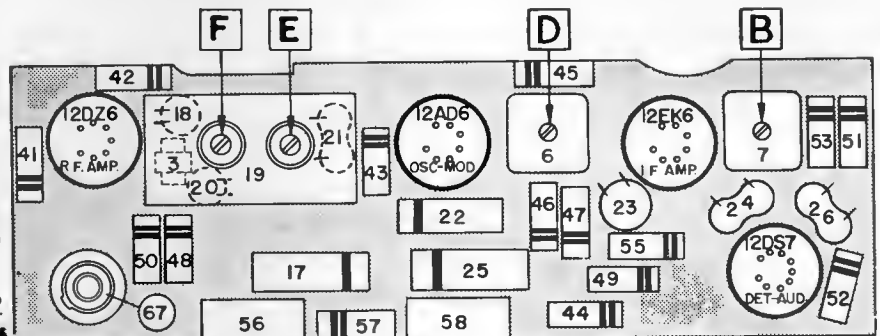
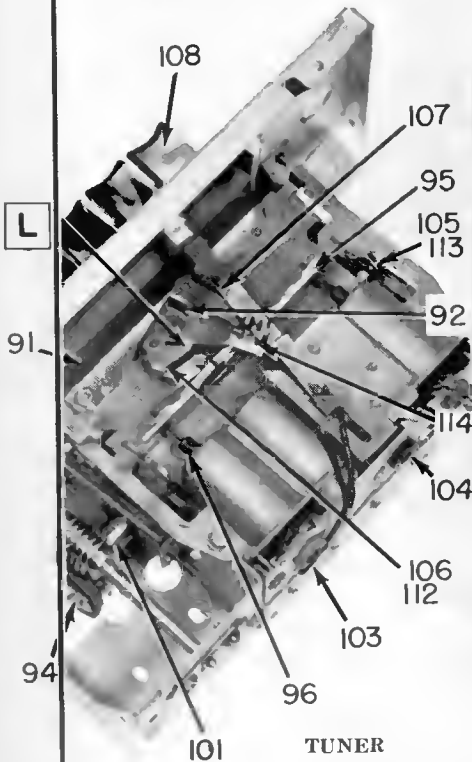
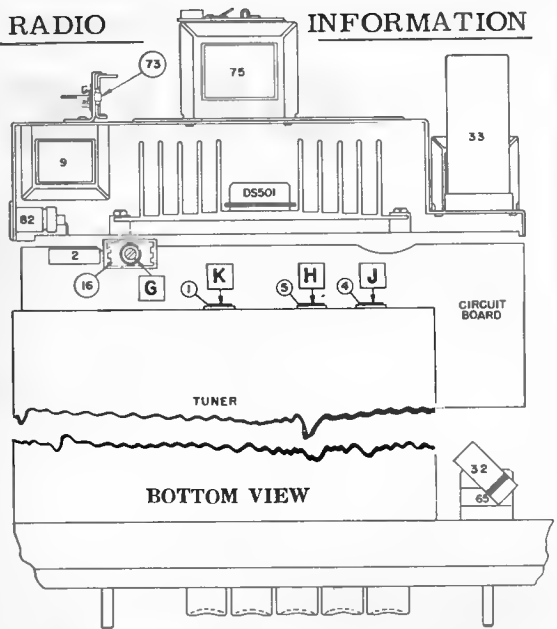

WHITE NUMBERS ON PRINTED CIRCUIT BOARD DRAWING CORRESPOND TO NUMBERS ENCIRCLED ON SCHEMATIC.

STEPS	SERIES CAPACITOR OR DUMMY ANTENNA	CONNECT SIGNAL GENERATOR TO	SIGNAL GENERATOR FREQUENCY	TUNE RECEIVER TO	ADJUST IN SEQUENCE FOR MAX. OUTPUT
1	0.1 Mfd.	12AD6 Grid (Pin #7)	262 KC	High Frequency Stop	A, B, C, D
2	0.000068 Mfd.	Antenna Connector	1615 KC	High Frequency Stop	*E, F, G
3	0.000068 Mfd.	Antenna Connector	600 KC	Signal Generator Signal	J, K
4	0.000068 Mfd.	Antenna Connector	1615 KC	High Frequency Stop	F, G
5	0.000068 Mfd.	Antenna Connector	1100 KC	Signal Generator Signal	L**

*Before making this adjustment check mechanical setting of oscillator core "H." The rear of the core should be 1/16" from the mounting end of the coil form. (This measurement is readily made by inserting a suitable plug in the mounting end of the coil form.) Core adjustment should be made with a non-metallic screwdriver.

**L is the pointer adjustment which is on the connecting link, between the pointer assembly and core guide bar (See tuner Dwg.). It should be adjusted so that when looking directly at the dial the pointer is on the 1100 KC mark. This setting is to give the correct relationship between the pointer and the dial when the radio is installed in a car.

DELCO OLDSMOBILE 989171 (Continued)

For list of similar models, see preceding page.

WHITE NUMBERS ON PRINTED CIRCUIT DRAWING CORRESPOND TO THE ENCIRCLED NUMBERS ON SCHEMATIC.

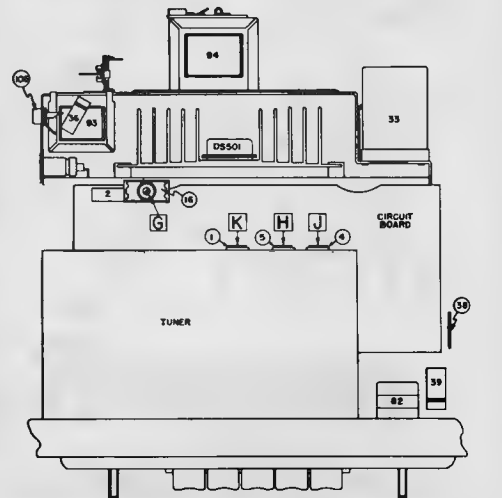
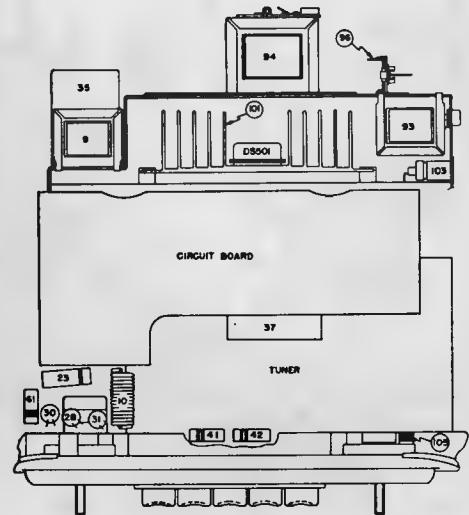
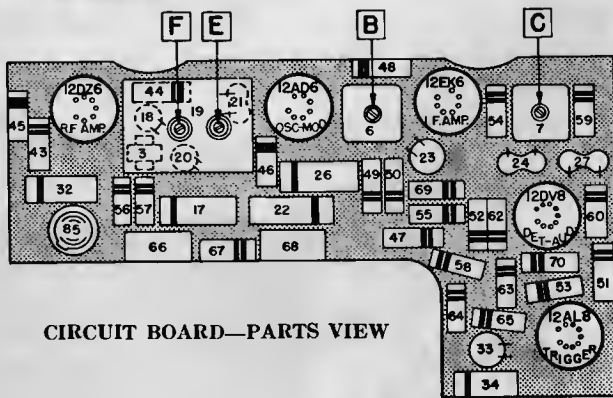
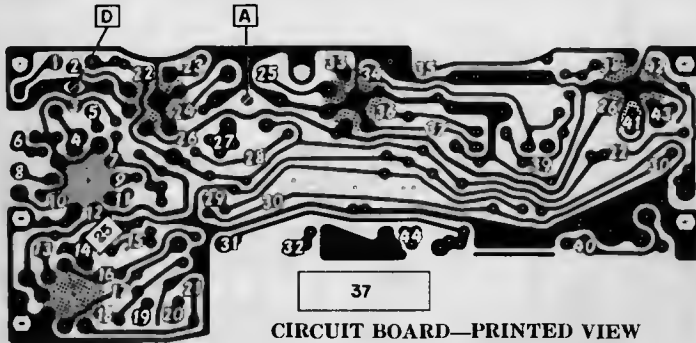

SIGNAL SEEKING TUNER ALIGNMENT PROCEDURE

NOTE: When aligning the signal seeker tuner type radio, be sure to use a vacuum tube voltmeter as indicated.

- Output Meter Connection.....VTVM from AVC line (#27 Island-Circuit Board) To Chassis
- Generator Return..... Receiver Chassis
- Dummy Antenna.....In Series With Generator
- Sensitivity Control.....Maximum
- Volume Control.....Maximum Volume
- Tone Control.....Treble
- Generator Output.....Not to exceed 2 volts at VTVM

STEP	DUMMY ANTENNA	CONNECT SIGNAL GENERATOR TO	SIGNAL GENERATOR FREQUENCY	TUNE RECEIVER TO	ADJUST IN SEQUENCE FOR OUTPUT INDICATED
1	0.1 Mfd.	12AD6 Grid (Pin 7)	262 KC	*High Frequency Stop	A, B, C (Max.), D (Min.)
2	.000068 Mfd.	Antenna Connector	1615 KC	High Frequency Stop	**E, F, G (Max.)
3	.000068 Mfd.	Antenna Connector	600 KC	Signal Generator Signal	J, K (Max.)
4	.000068 Mfd.	Antenna Connector	1615 KC	Signal Generator Signal	F, G (Max.)
5	.000068 Mfd.	Antenna Connector	1100 KC	Signal Generator Signal	***L

*To tune to high frequency, put a .070" feeler gauge in slot against the high frequency stop. (See Page 30. Depress station selector bar and allow the treadle bar arm to run against the feeler gauge. Turn the radio off and then back on. This positions the tuner near the point where the treadle switch closes.

**Before making this adjustment, check the setting of oscillator core "H." The rear of the core should be 1 5/8" from the mounting end of the coil form. This measurement is readily made by inserting a suitable plug in the mounting end of the coil form. The core adjustment is made from the mounting end of the coil form with a non-metallic screwdriver.

***"L" is the pointer adjustment slot on the pointer assembly—adjust so pointer reads 1100 KC. With the radio installed and the antenna plugged in, adjust the antenna trimmer "G" for maximum volume with the radio tuned to a weak station between 600 and 1000 KC (see sticker on case.)

EMERSON RADIO
Model 877, Chassis 120392B

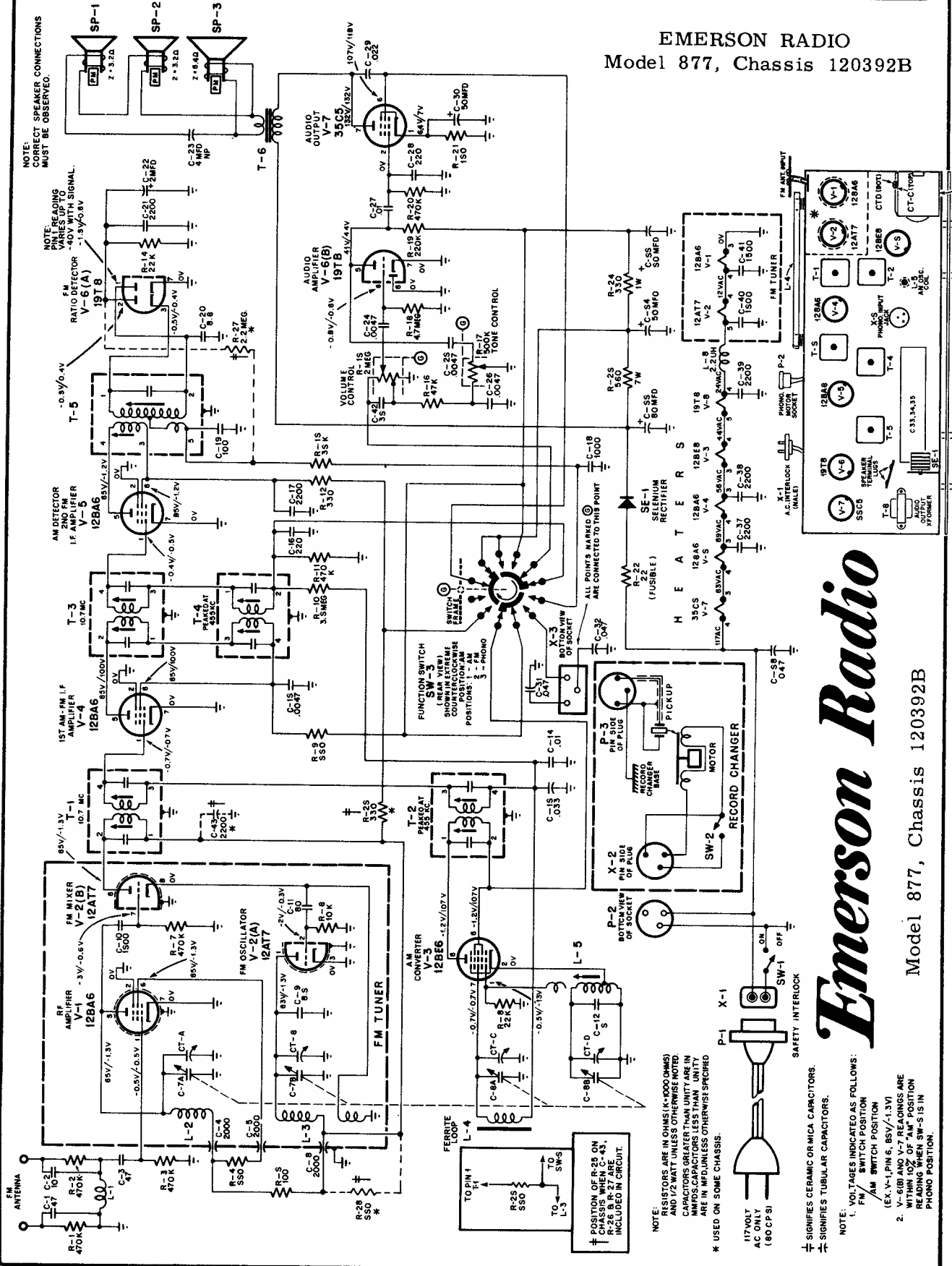

NOTE: CORRECT SPEAKER CONNECTIONS MUST BE OBSERVED.

NOTE: PINT READING VARIES UP TO $\pm 1.5\%$ OF SV.

NOTE: RESISTORS ARE IN OHMS (K=1000 OHMS) UNLESS OTHERWISE NOTED. CAPACITORS ARE IN PFD UNLESS OTHERWISE NOTED. CAPACITORS LESS THAN 100 PFD ARE IN MFD UNLESS OTHERWISE SPECIFIED * USED ON SOME CHASSIS.

117VOLT AC ONLY (60 CPS)

⊕ SIGNIFIES CERAMIC OR MICA CAPACITORS.
⊕ SIGNIFIES TUBULAR CAPACITORS.

- NOTE: 1. VOLTAGES INDICATED AS FOLLOWS:
FM SWITCH POSITION (EX. V-1, PIN 6, 85V/-1.3V)
2. V-6(B) AND V-7 READINGS ARE WITHIN 10% OF "AM" POSITION READING WHEN SW-1 IS IN PHONO POSITION.

Emerson Radio

Model 877, Chassis 120392B

Emerson

Models 834X, 890, 892A, Chassis 120394B

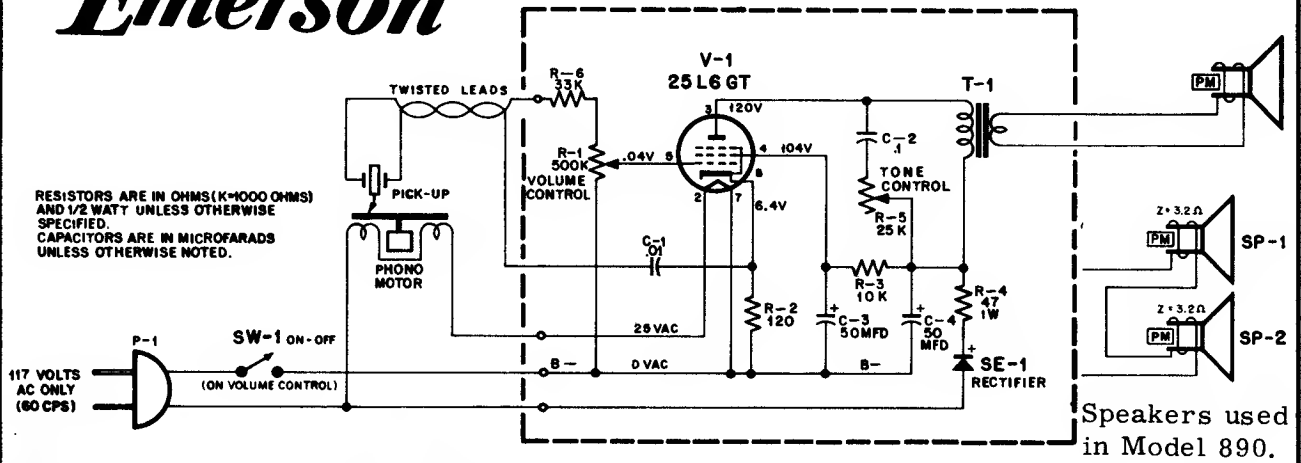

Emerson

MODELS:
893B, 894B

CHASSIS:
120430B, 432B

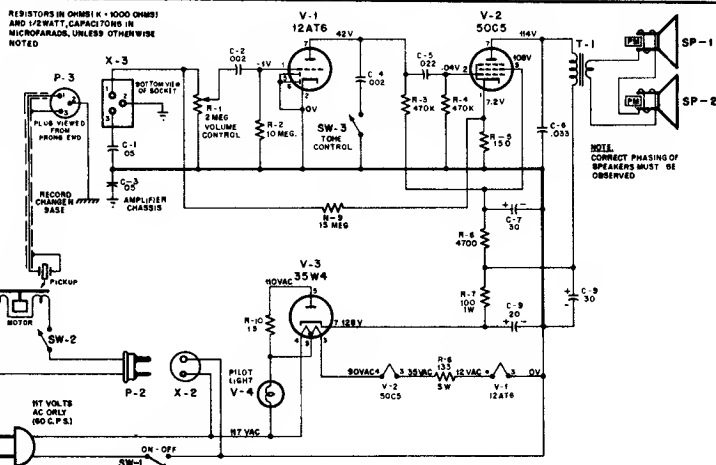
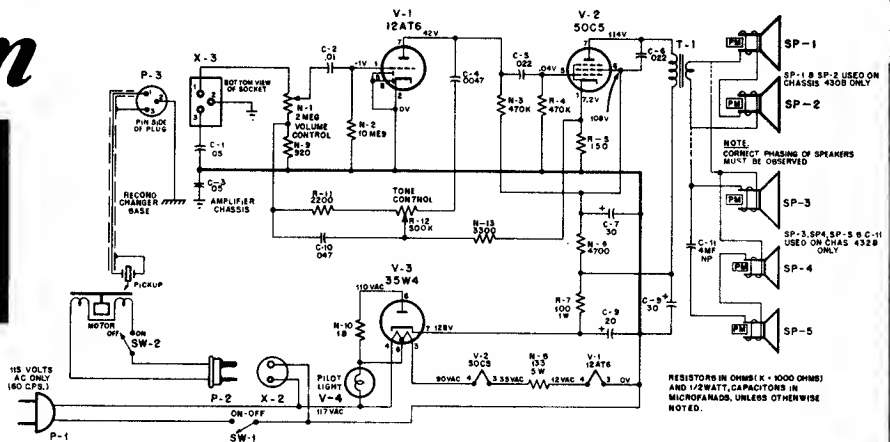

Emerson

Model 891B, Chassis 120399B

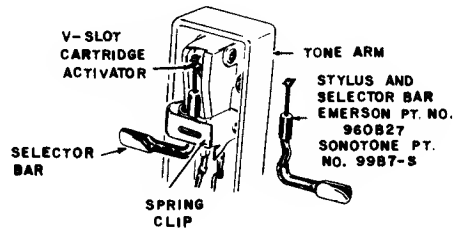

TO REPLACE STYLUS AND SELECTOR BAR

For best operation and record tracking, it is recommended that the stylus (needle) and selector bar (flip-over arm) be replaced as a single unit. To change this unit, proceed as follows:

1. Lift up tone arm.
2. With one hand, hold spring clip in a direction away from tone arm.
3. With other hand, slide out selector bar and stylus as shown in diagram.
4. To replace new stylus and selector bar, reverse above procedure.

1. Voltages indicated are positive d.c., resistances in ohms, unless otherwise indicated.
2. Measurements made with voltohmmyst or equivalent.
3. All measurements taken from pin to B neutral unless otherwise indicated.
4. Voltage measurements taken with:
 - a) Line voltage maintained at 117 volts a.c. only.
 - b) Volume control set for maximum volume.
 - c) Phono plugs disconnected.
5. Resistance measurements taken with:
 - a) Power line cord disconnected from outlet.
 - b) Volume control set for maximum volume.
 - c) Phono plugs disconnected.
6. Nominal tolerance on component values make possible a variation of $\pm 15\%$ in voltage and resistance readings.

Emerson Radio

MODEL 888
"TRANSTIMER"
CHASSIS 120416

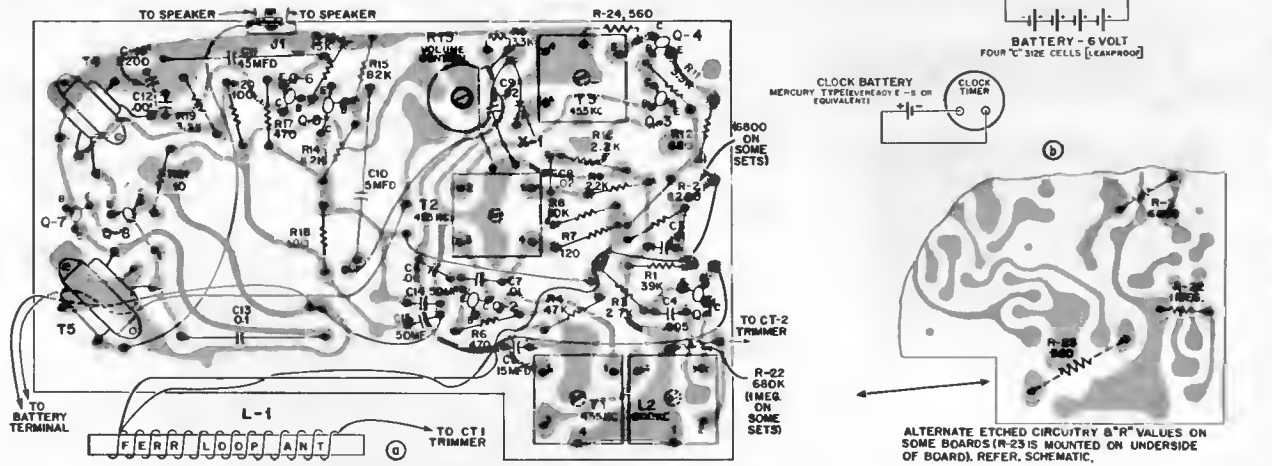
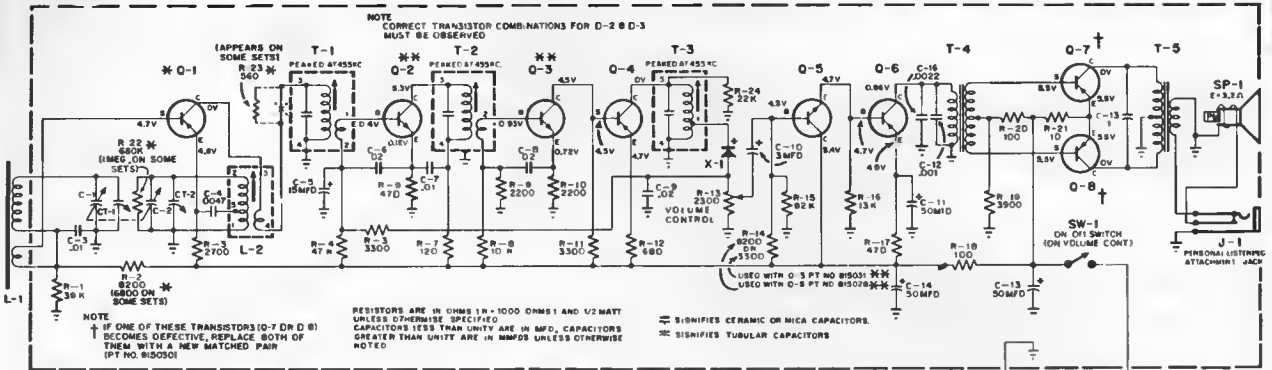

It will be seen from the schematic drawing of the 888 that certain transistors are used in pairs and are associated with specified resistors. Some individual transistors must likewise be used with specific resistors. Because of the small physical size of the transistors, the 1st three digits, "815", have been replaced by the letter, "E"

TRANSISTOR PAIRS	ASSOCIATED	TRANSISTOR PAIRS	ASSOCIATED	TRANSISTOR	ASSOCIATED	TRANSISTOR	ASSOCIATED
Q2	Q3	R12	Q2	Q3	R12	Q5	R14
815026C	815026A	680	815026C	815026E	680	815031	3800
815026B	815026B	680	815026D	815026D	680	815028	8200
815026B	815026D	680	815026C	815026F	330	815032	4700
						815033	6800
						815034	8200
						815035	10,000

TRANSISTOR SUBSTITUTES	TRANSISTOR NOS.	TRANSISTOR SUBSTITUTES	TRANSISTOR NOS.	TRANSISTOR SUBSTITUTES	TRANSISTOR NOS.
FDR	USE	FOR	USE	FOR	USE
815026B	815026D	815026F	No. Subst.	815033	815032
815026A	815026E	815028	815032	815034	815032
815026C	No Subst.	815031	815032	815035	815032

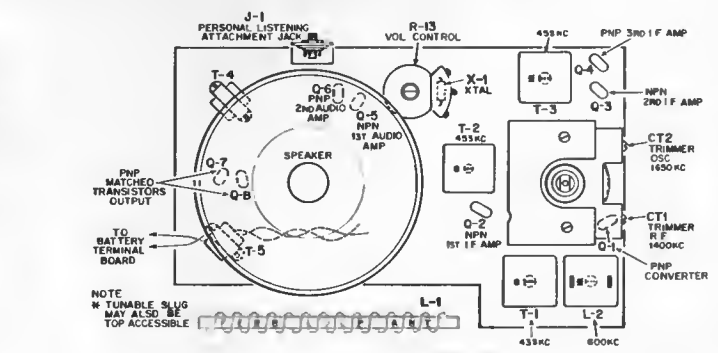
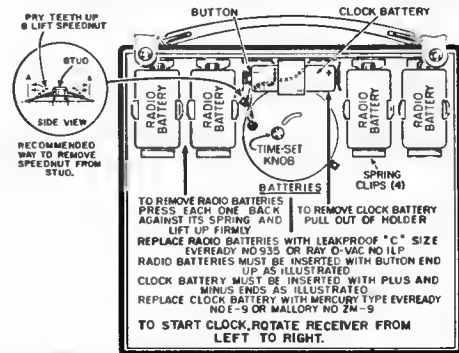

Emerson Radio

Model 895B, Chassis 120431B

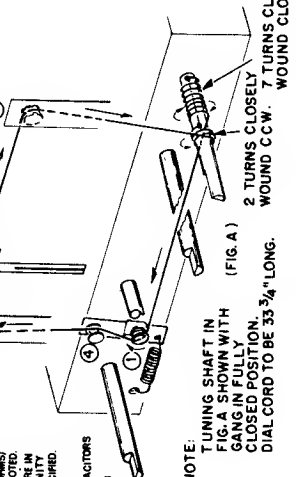
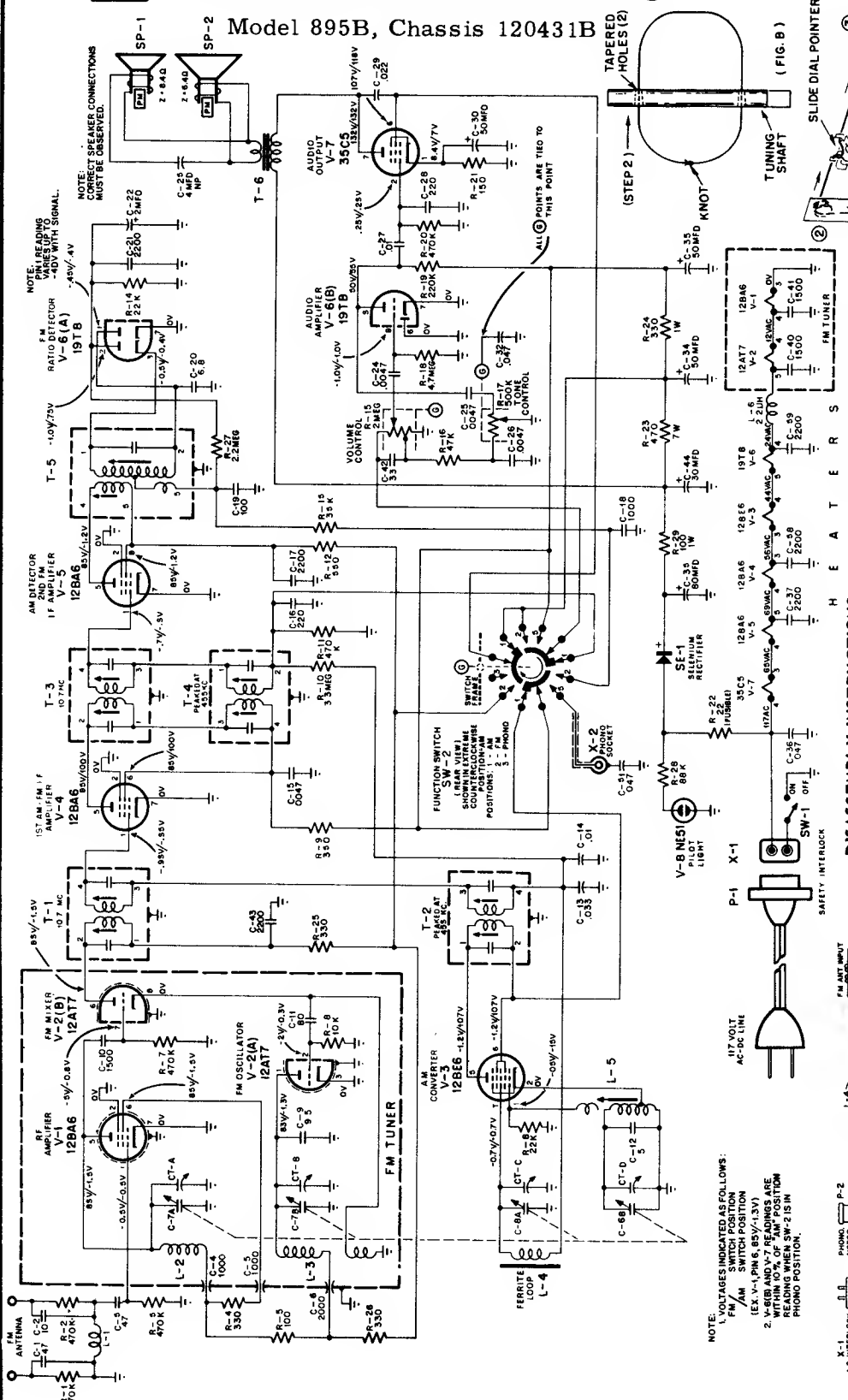

NOTE: TUNING SHAFT IN FIG. A SHOWN WITH GANG IN FULLY CLOSED POSITION. DIAL CORD TO BE 33 3/4" LONG. 2 TURNS CLOSELY WOUND C.C.W. 7 TURNS CLOSELY WOUND C.C.W.

DISASSEMBLY INSTRUCTIONS

Remove screws from cabinet back. Grasp line cord at point where it is connected to back and pull free of interlock. Remove back. Remove 3 control knobs and 1 tuning knob; disconnect built-in FM antenna and remove antenna terminal. Unsolder 2 speaker leads at chassis solder lug strip and unscrew chassis bolts from underside of cabinet. TO STRING DIAL:

1. STRING THROUGH SMALLER DIAMETER OF TAPERED HOLES (FIG. B) AND KNOT.
2. PULL KNOT THROUGH HOLE (FIG. B) AND ROTATE SHAFT COUNTERCLOCKWISE UNTIL GANG IS FULLY CLOSED.
3. WIND 7 REAR TURNS CLOCKWISE.
4. LOOP STRING OVER PULLEY ④ AND STUDS ② AND ③ (FIG. A).
5. WIND 2 FRONT TURNS COUNTERCLOCKWISE WORKING TOWARDS FRONT OF SHAFT.
6. STRING LOOPED CORD UNDER PULLEY ④ (FIG. A).

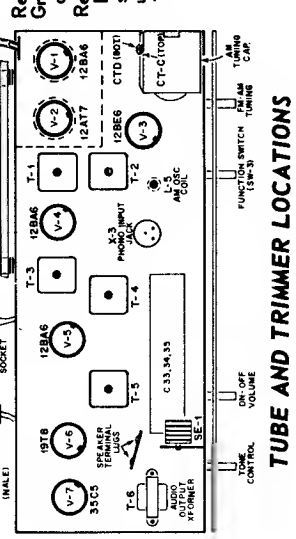

NOTE: 1. VOLTAGES INDICATED AS FOLLOWS: FM/AM SWITCH POSITION (EX. V-1, PH 6, 85V/-1.3V) 2. V-6(B) AND V-7 READINGS ARE IN OHMS UNLESS OTHERWISE SPECIFIED. PHONO POSITION. SW-2 IS ON.

TUBE AND TRIMMER LOCATIONS

VOLUME R-19, MOST-OFTEN-NEEDED 1959 RADIO SERVICING INFORMATION

EMERSON RADIO Model 999, Chassis 120433B, and Model 999R, Chassis 120433R

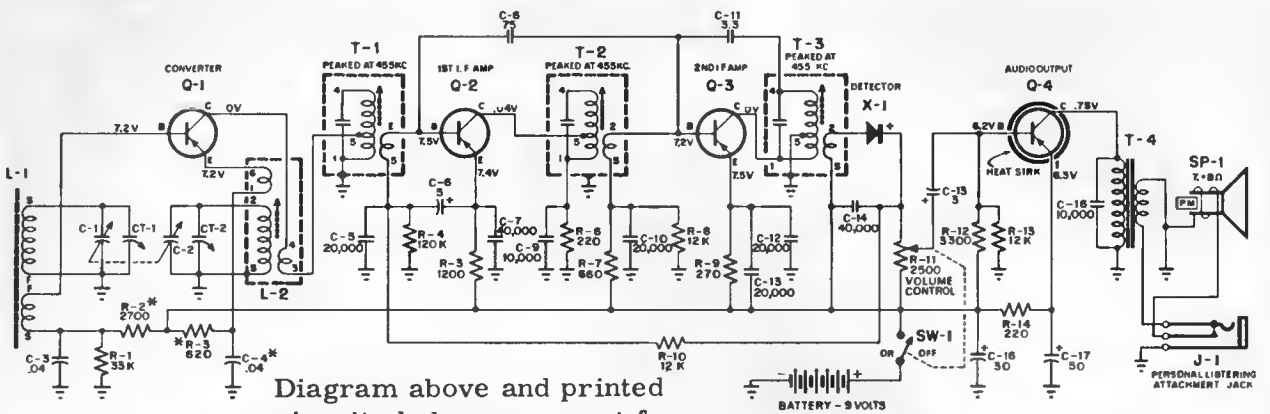

- NOTES:
- ⊕ SIGNIFIES CERAMIC OR MICA CAPACITORS, CAPACITY IN MICRO-MICROFARADS.
 - ⊗ SIGNIFIES TUBULAR CAPACITORS, CAPACITY IN MICROFARADS.
 - RESISTORS ARE IN OHMS (K=1000 OHMS) AND Ω V2 WATT.
 - * SOME SETS WILL USE THE FOLLOWING VALUES:
 R-2, 6800 Ω
 R-3, 2700 Ω
 C-4, 20,000 (CERAMIC)

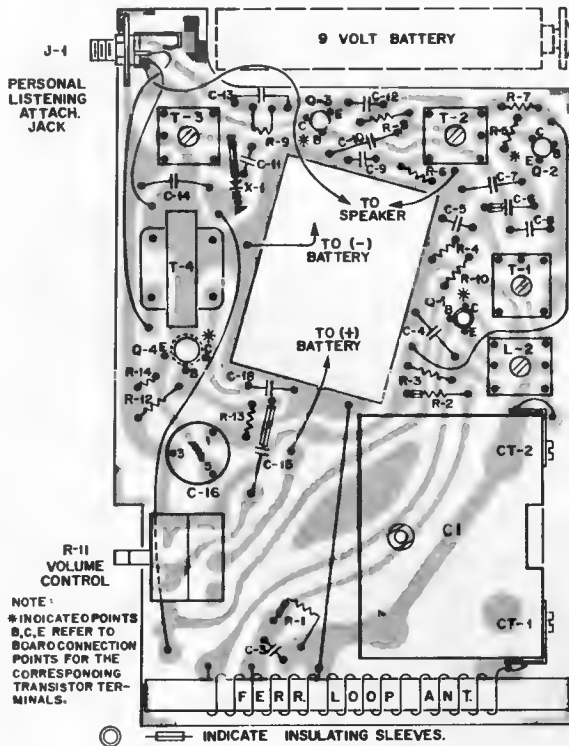

PRINTED CIRCUIT CHASSIS DIAGRAM (TOP VIEW)

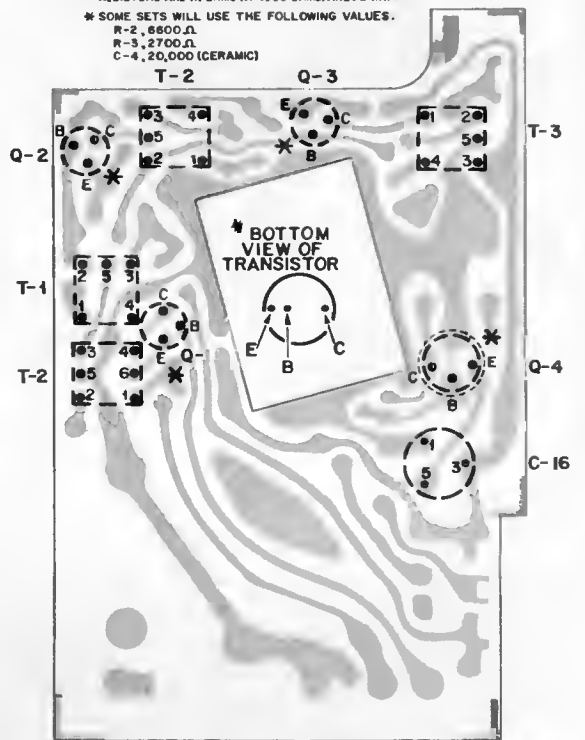

PRINTED CIRCUIT CHASSIS DIAGRAM (BOTTOM VIEW)

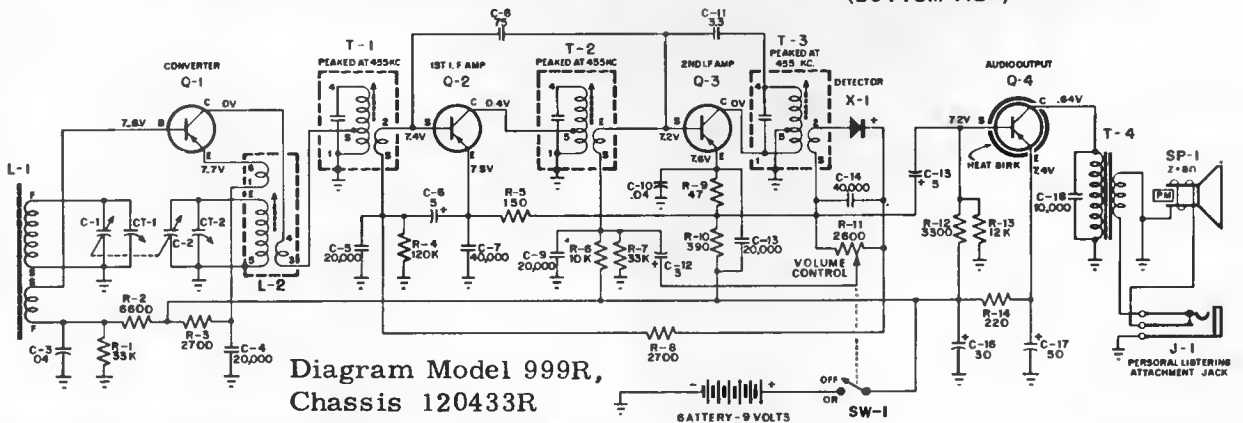

Emerson Radio

Models 896B, 970, 971, 971A, Chassis 120455B,
and Model 902, Chassis 120459B.

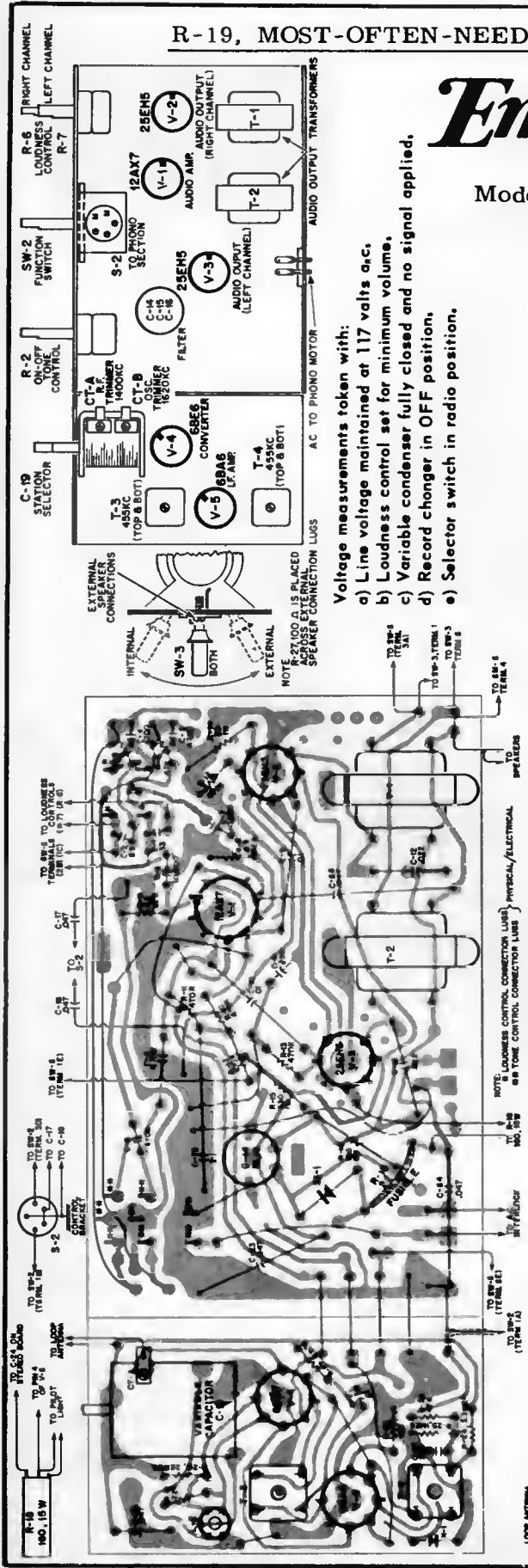

- AC TO PHONO MOTOR
- Voltage measurements taken with:
- Line voltage maintained at 117 volts a.c.
 - Loudness control set for minimum volume.
 - Variable condenser fully closed and no signal applied.
 - Record changer in OFF position.
 - Selector switch in radio position.

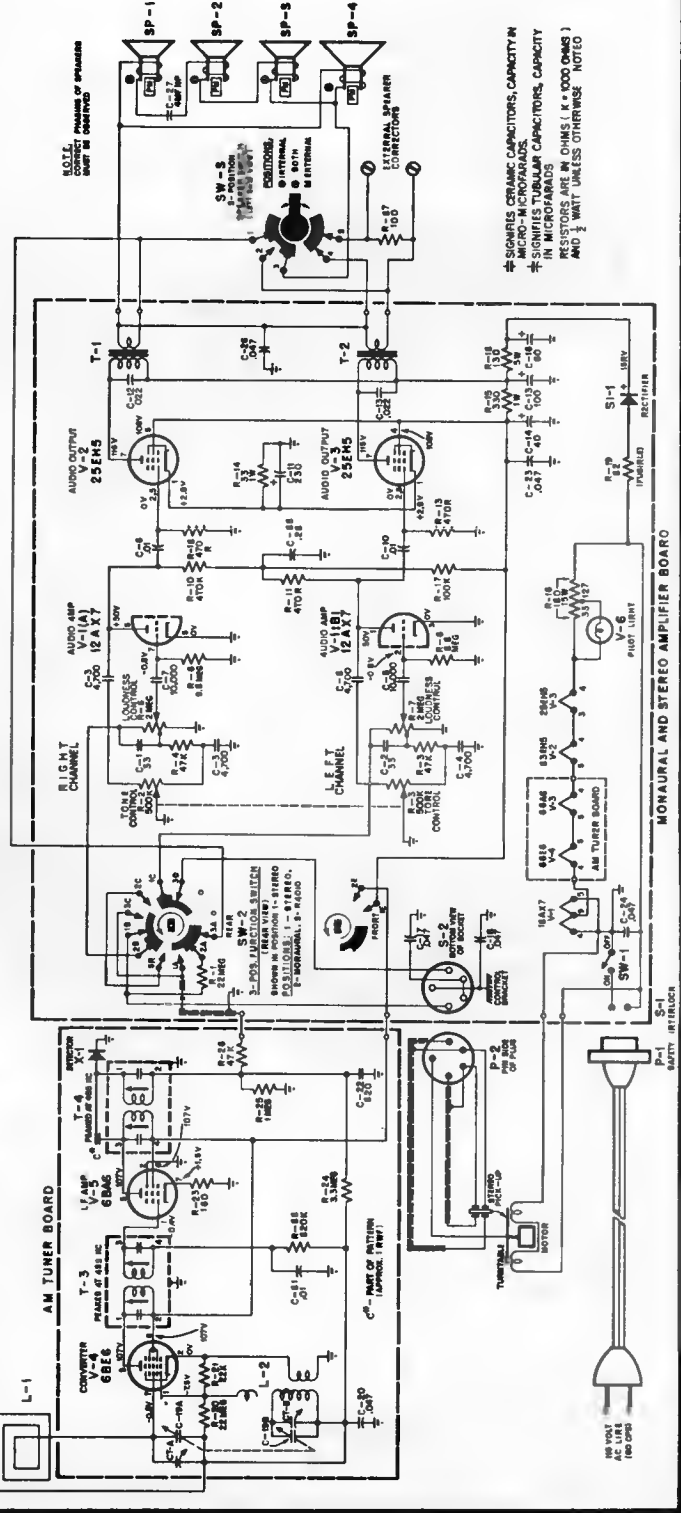

NOTE: CRAMIC CAPACITORS, CAPACITY IN MICROFARADS
RESISTORS ARE IN OHMS (K = 1000 OHMS) AND 1/2 WATT UNLESS OTHERWISE NOTED

Emerson Radio

MODEL 898B
CHASSIS 120456B
MODELS 970, 971, 971A

MODEL 903, chassis 120462B, is electrically similar to model 898B, chassis 120456B. Therefore, all control panel information is directly applicable, with the addition that the speaker selector switch is mounted on the control panel in model 903.

DISASSEMBLY INSTRUCTIONS

NOTE: To replace tubes, only masonite back within cabinet need be removed.

Record Changer:

Remove three Phillips head screws holding masonite back to cabinet and remove back.

Remove four Phillips head screws holding changer mounting board to cabinet.

Tilt mounting board up and back to a stable vertical position.

Remove five-prong plug and AC plug and line cord from amplifier chassis. (Unstaple fishpaper wire holders.)

Remove record changer.

To reassemble, reverse procedure.

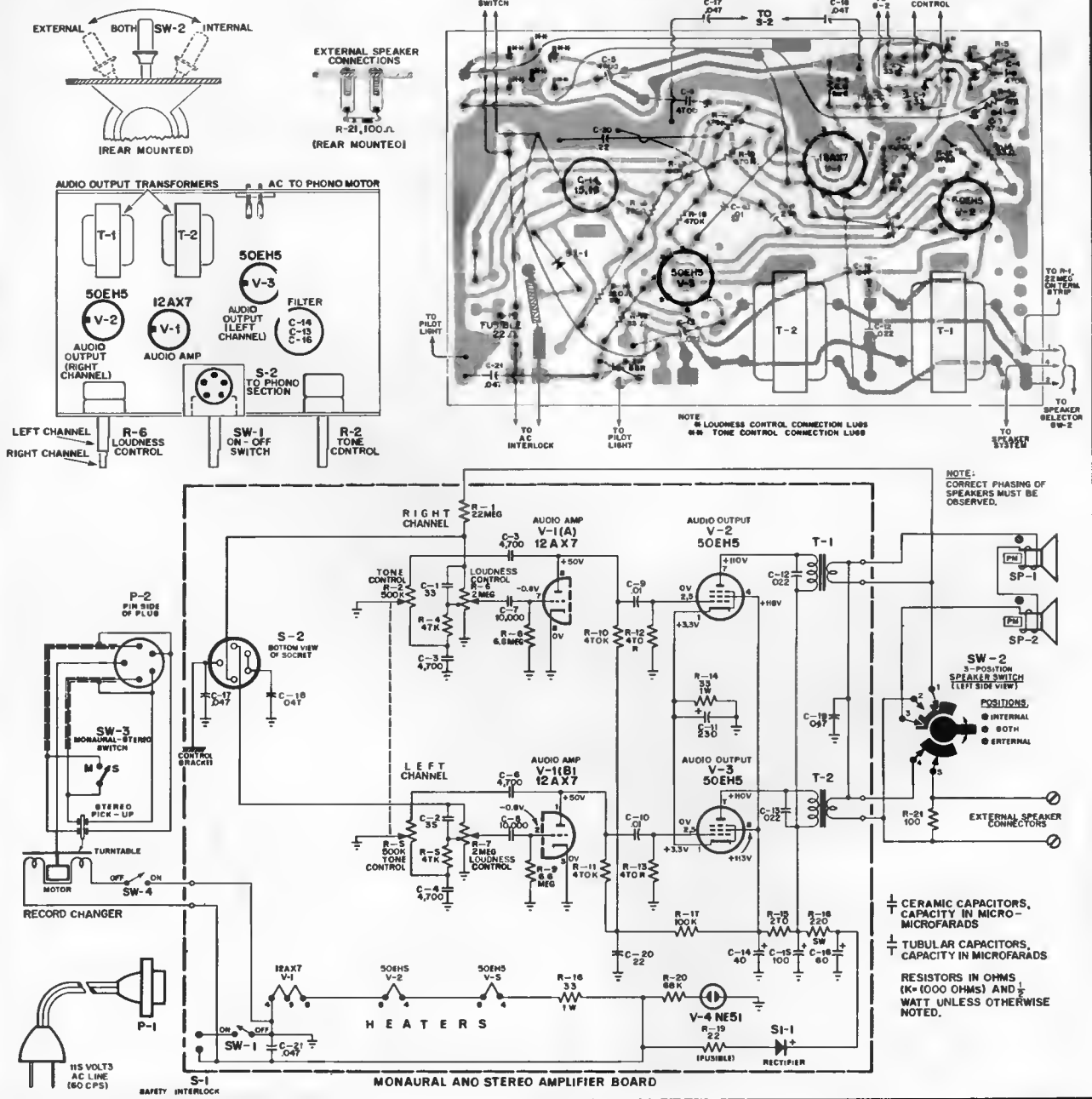

GENERAL ELECTRIC COMPANY

MODEL S
T105A
T106A,B
T107B

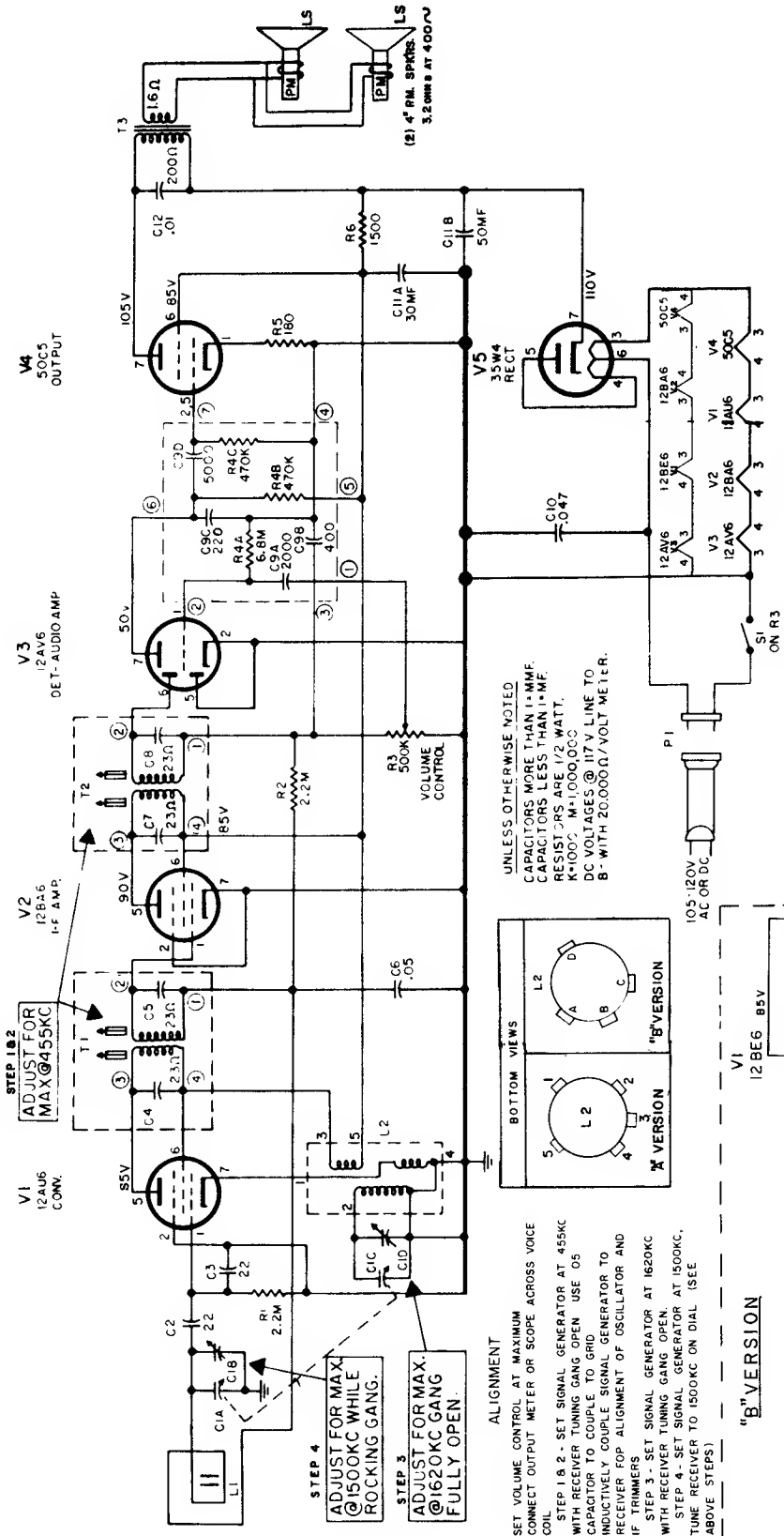

TO REMOVE CHASSIS FROM CABINET

To remove chassis from cabinet, remove cabinet back. Unsolder the output transformer leads from the speaker. Remove the four self-tapping screws, (hex heads) one on each corner of the chassis, and the single hex screw just below the tuning gang capacitor. Pull off the volume control knob. The tuning control knob is held to the cabinet, so the chassis must be pulled out of the cabinet, at the same time pulling it off the tuning knob, which remains on the cabinet. When pulling out the chassis, it is best to grasp the tuning capacitor (C1) by the thumb and forefinger of one hand, the tuning knob by the other hand and pull. CAUTION: It is important to use extreme care replacing parts and/or soldering on this chassis. Too much heat on the chassis will cause the copper plating to become unbonded. Only apply the soldering iron long enough to melt the solder and pull out the part to be replaced.

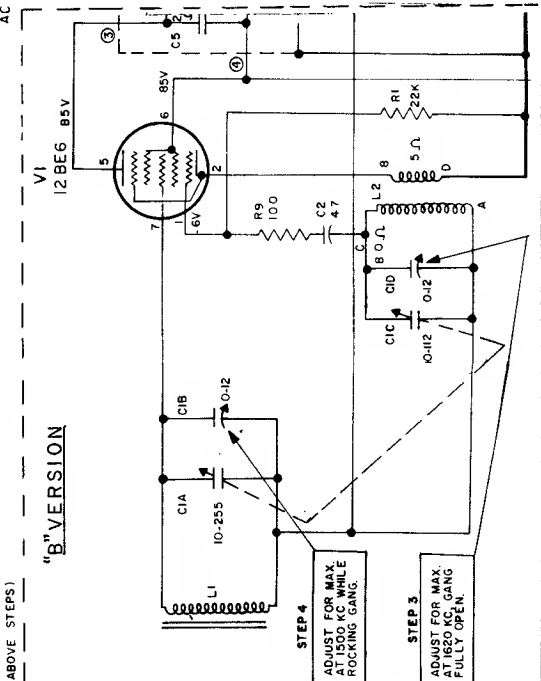

GENERAL ELECTRIC COMPANY

MODELS
TI20A,B

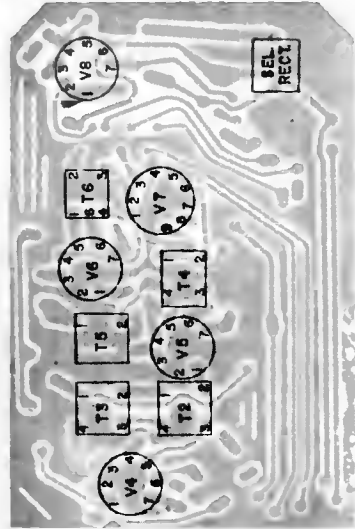
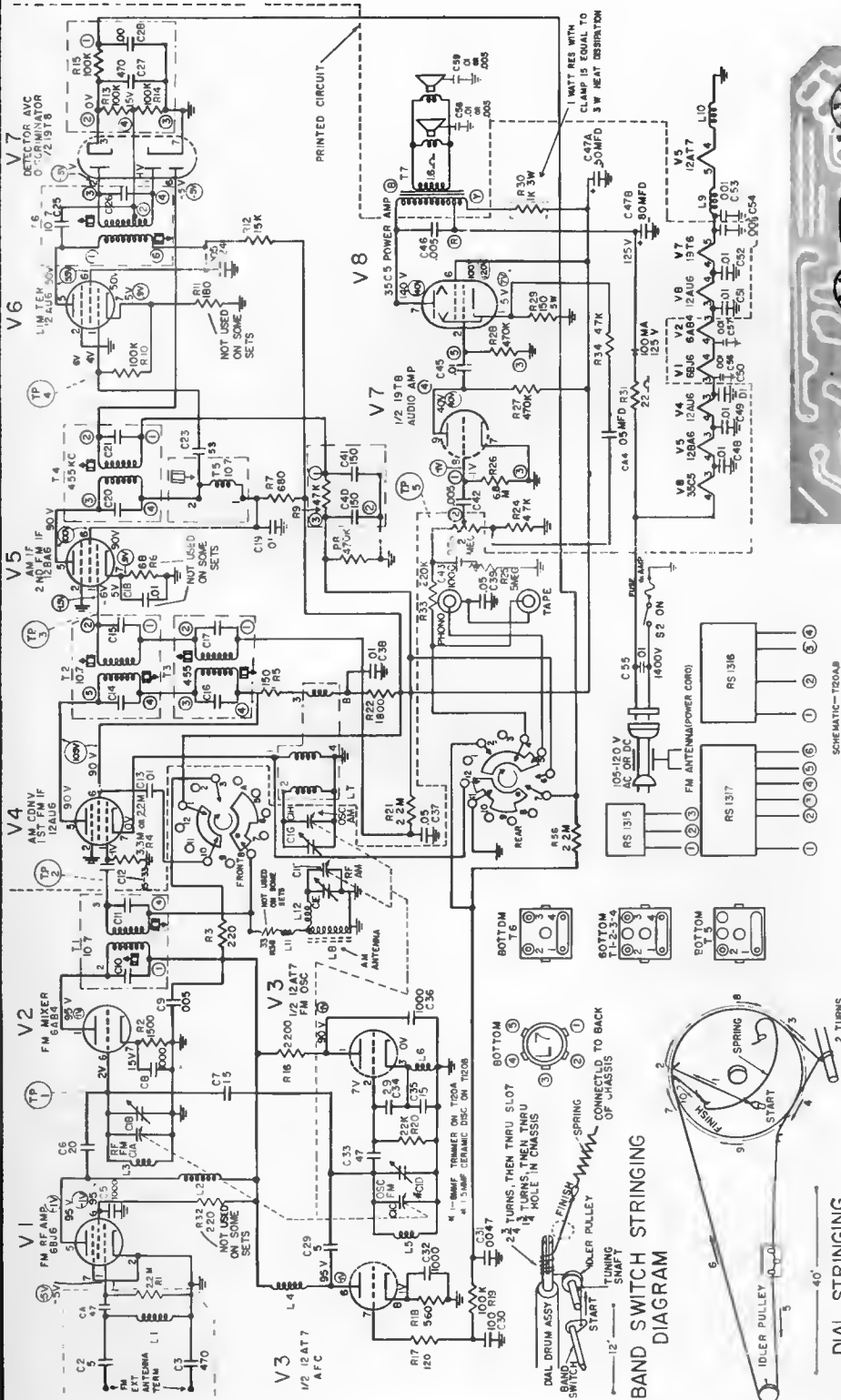

Component board, bottom view.

UNLESS OTHERWISE NOTED
RESISTORS IN OHMS-X.1000 INDICATED
CAPACITORS IN MICRO-FARADS
RESISTORS ARE 1/2 WATT UNLESS
OTHERWISE SHOWN

ALL DC VOLTAGES TAKE AT
100 VOLTS LINE WITH A 20,000
OHMS PER VOLT
CIRCLED VOLTAGES ARE AM
TAKEN IN AM BAND SW POS
ALL OTHER VOLTAGES ARE FM
TAKEN IN FM BAND SW POS.

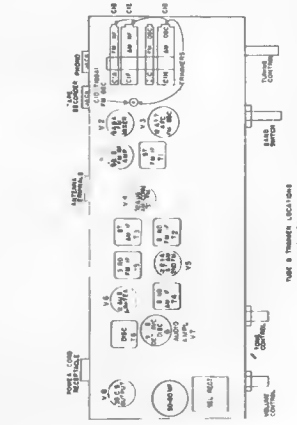
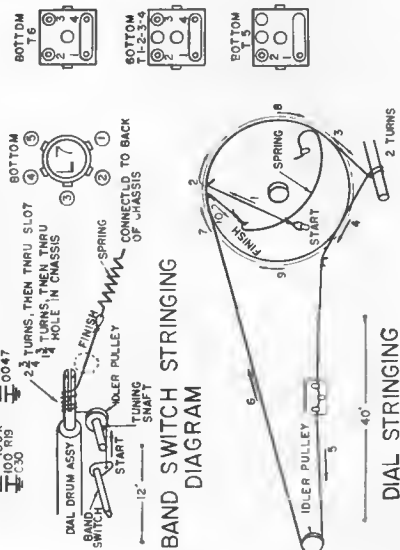

GENERAL ELECTRIC COMPANY

Models T125A, T126A, T127A

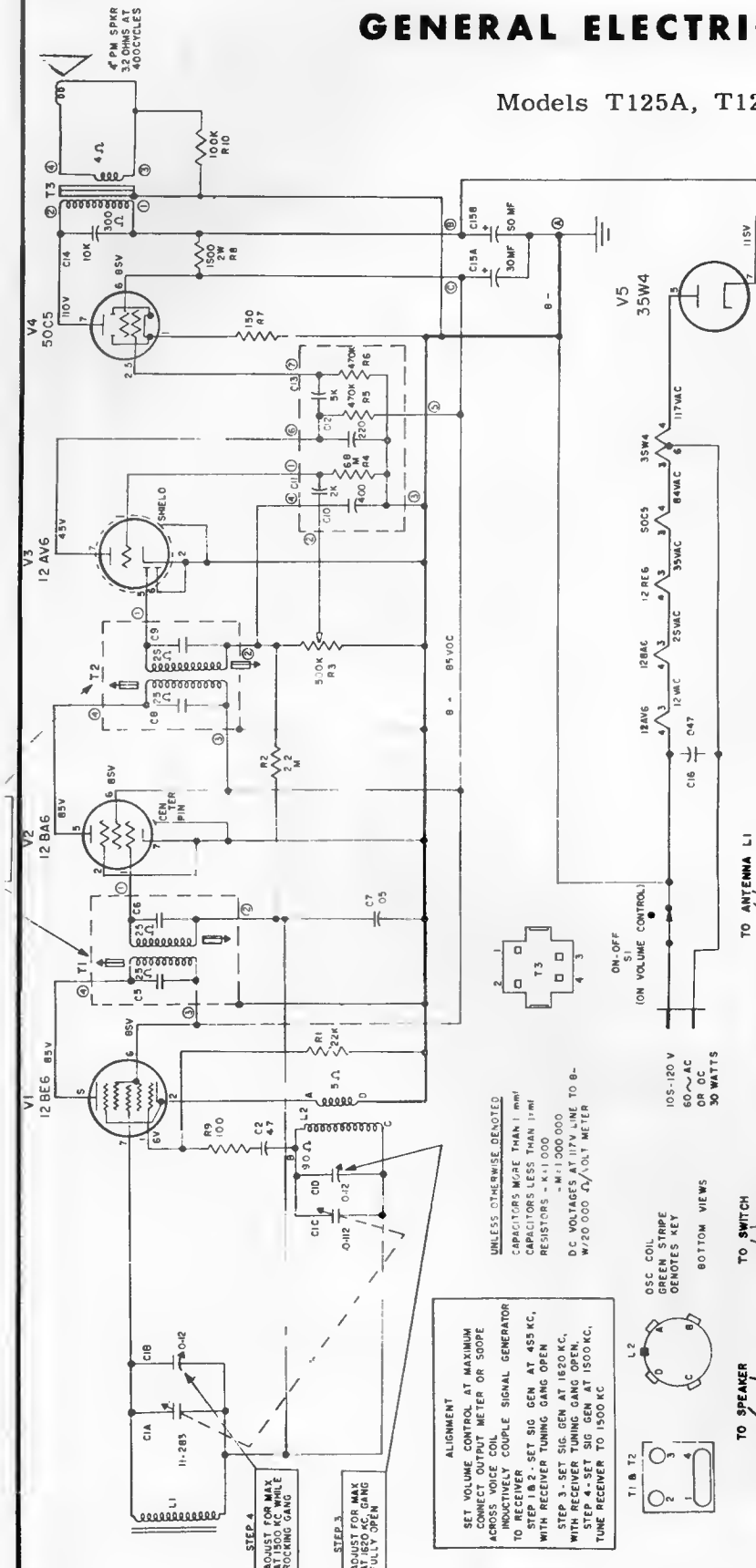

TO REMOVE CHASSIS FROM CABINET:

After removing cabinet back remove the screw on the cabinet bottom that holds the chassis board support. The tuning knob is a captive knob and remains in the cabinet front. Close the tuning gang to prevent any possible damage to the plates. Slide one hand under the printed chassis board placing the fingers over the front edge. Slide the board back out of the grooves on either end simultaneously removing the tuning gang shaft from the tuning knob. When replacing the chassis, close the tuning gang and line the flat side of the tuning gang shaft up with the flat in the tuning knob, place the ends of the board in the grooves and push on the edge of the board, not on the components. The tuning shaft will enter the tuning knob and the front edge of the board will seat itself in the grooved bosses inside the cabinet front. Replace the board support and self-tapping screw.

ALIGNMENT
 SET VOLUME CONTROL AT MAXIMUM
 CONNECT OUTPUT METER OR SLOPE
 ACROSS VOICE COIL
 INDUCTIVELY COUPLE SIGNAL GENERATOR
 TO TUNING GANG
 STEP 1. SET SIG. GEN. AT 455 KC.
 WITH RECEIVER TUNING GANG OPEN
 STEP 2. SET SIG. GEN. AT 1520 KC.
 WITH RECEIVER TUNING GANG OPEN.
 STEP 3. SET SIG. GEN. AT 1500 KC.
 WITH RECEIVER TUNING GANG OPEN.
 STEP 4. SET SIG. GEN. AT 1500 KC.
 TUNE RECEIVER TO 1500 KC

UNLESS OTHERWISE DENOTED
 CAPACITORS MORE THAN 1 MMF
 CAPACITORS LESS THAN 1 MMF
 RESISTORS - K=1,000
 -M=1,000,000
 DC VOLTAGES AT 117V LINE TO B-
 W/20,000 Ω/VOLT METER

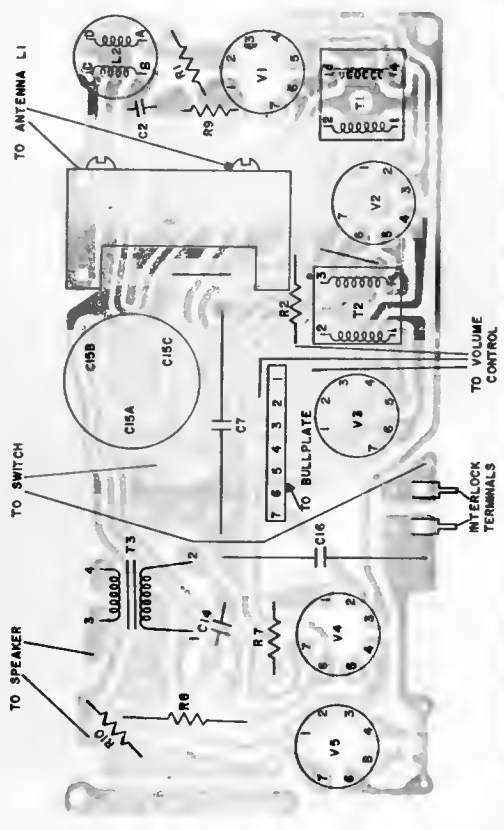

GENERAL ELECTRIC COMPANY

Models T130A,B, T131A,B, T132A,B

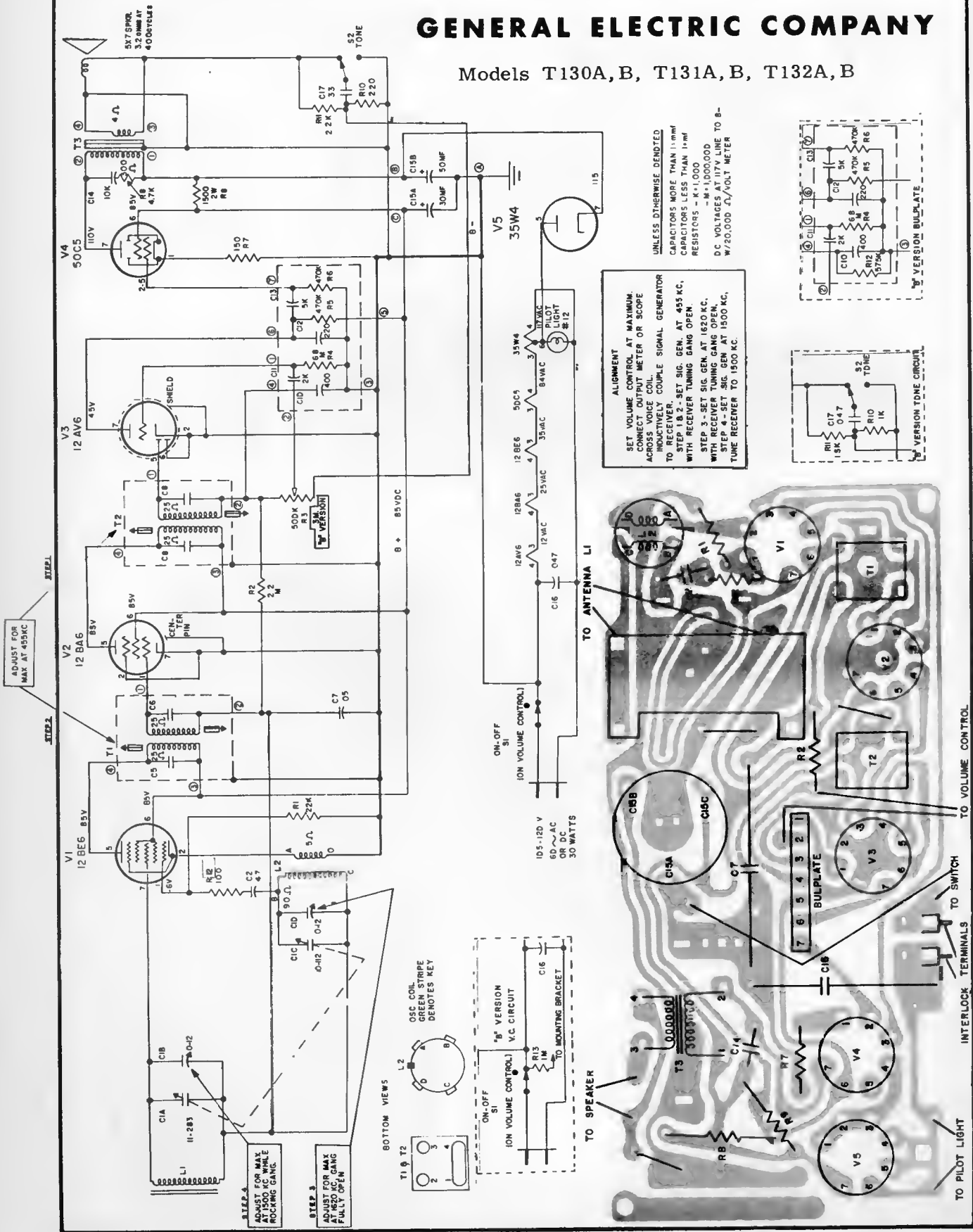

GENERAL ELECTRIC

Model T135A

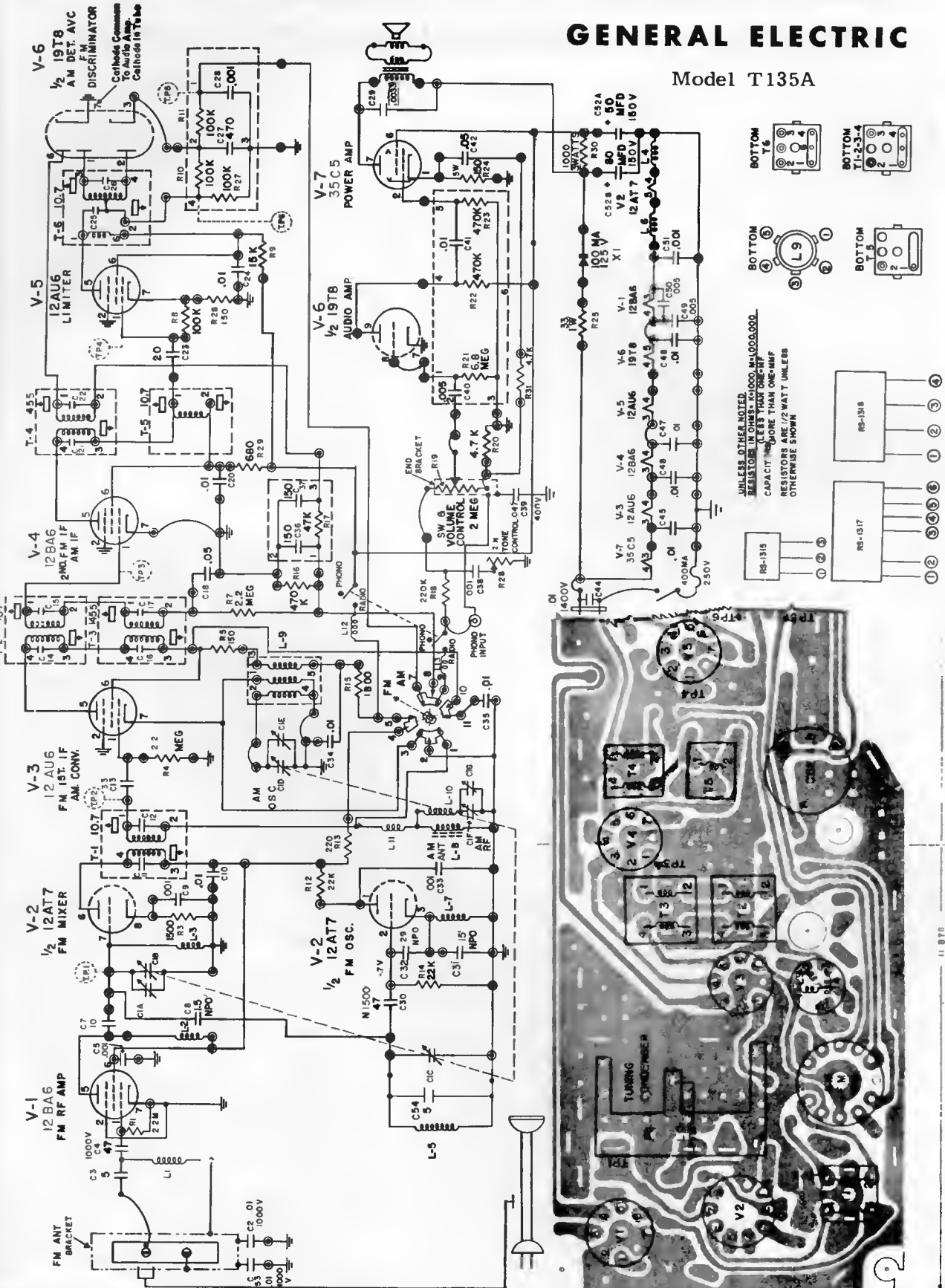

GENERAL ELECTRIC COMPANY

Models C-400A, C-401A

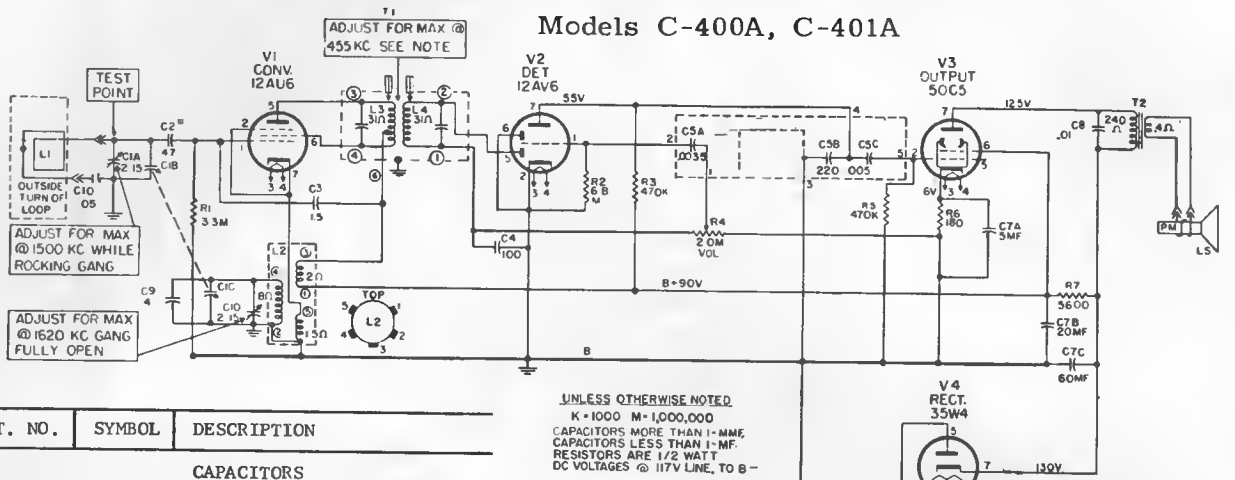

CAT. NO.	SYMBOL	DESCRIPTION
CAPACITORS		
RCE-217	C7A, B, C	5mf., @25V., 20mf., & 60mf., @150V., Electro.....
RCN-048	C3 C6	1.5mf., 20%, 500V., Ceramic .047mf., +40-10%, 600V., Molded.....
RCT-097	C1A, B C, D	Tuning Capacitor, Two Gang
RCW-3036	C5A, B, C	.0035mf., 220mf., .005mf. Bullplate.....
RCW-3079	C4	100mf., 20%, 500V., Ceramic
RCW-3209	C9	4mmf., ±20%, 500V., Ceramic
RS-1022		.01mf., +40-10%, 400V. Ceramic
POTENTIOMETERS		
RS-1028	R4	Volume Control 2 meg.....
COILS & TRANSFORMERS		
RLC-135	L2	Oscillator Coil C400.....
RS-1414	L2	Oscillator Coil C401.....
RS-1027	T1	I.F. Trans. C400-C401.....
RTO-176	T2	Output Trans. C400-C401..

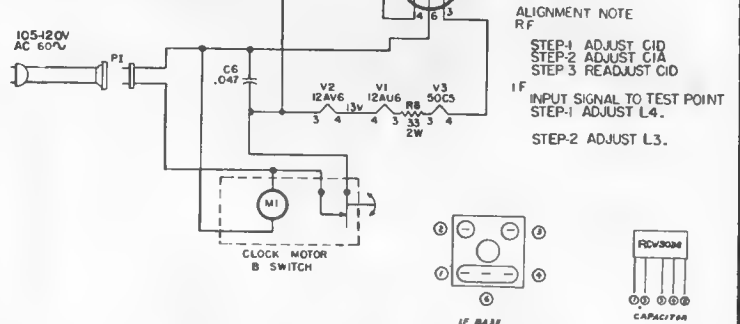

TO REMOVE CHASSIS FROM CABINET:
Remove cabinet back and interlock. Remove the five self-tapping screws (hex heads), one on each corner of the chassis, and the single hex screw just below the tuning gang capacitor. Pull off the volume control knob.

The tuning control knob is a captive knob which remains with the cabinet. The chassis must be pulled out of the cabinet and separated from the tuning knob simultaneously. When pulling out the chassis, first close the tuning capacitor. Grasp the tuning capacitor with the thumb and forefinger of one hand and the tuning knob with the other and pull the chassis out of the cabinet.

CAUTION:
It is important to use extreme care while replacing parts and or soldering on this chassis. Too much heat on the chassis will cause the copper plating to become unbonded. Only apply the soldering iron long enough to melt the solder and pull out the part to be replaced. A 35 watt soldering iron is recommended.

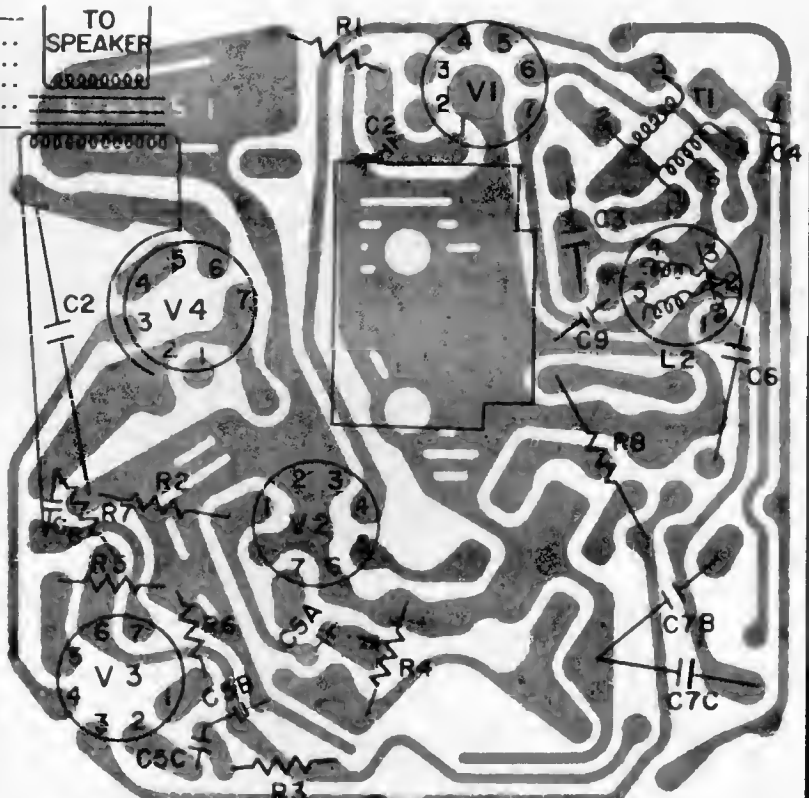

GENERAL ELECTRIC COMPANY

Models C405A, B, C406A, B

SPECIFICATIONS

CABINET:	Model C405A, B--Gray and White Model C406A, B--Pink
ELECTRICAL RATING:	105-120 volts AC 30 Watts @117 Volts AC
OUTPUT:	Undistorted .9 Watts Maximum 1.5 Watts

GENERAL INFORMATION

The main difference in the "A" and "B" versions of the C405 series of clock-radios is the oscillator-converter stage (V1). The "A" version uses a 12AU6 tube as V1 and the "B" version uses a 12BE6 as V1. The V1 stage for the "B" version is shown as a separate stage on the schematic.

The tuning knob is held to the cabinet and cannot be removed without first removing the chassis.

SERVICE NOTE

Always use an isolation transformer when servicing or aligning this receiver to protect personnel and test equipment.

When aligning, keep the signal input low so the AVC will not affect the output.

TO REMOVE CABINET FRONT

Remove the two screws located on each side of the cabinet back; unscrew the clock set knob; separate the cabinet front from the back. When separating the cabinet, the speaker leads must be unsoldered before complete separation of the cabinet can be accomplished. The speaker is mounted on the cabinet back with the radio chassis and clock mounted on the cabinet front.

TO REMOVE CHASSIS

Remove the volume control knob. Take out the four hexhead screws, one on each corner of the chassis board and one hexhead screw below the tuning condenser. Unsolder the one wire to switch on the clock and one to the clock motor.

Close the tuning condenser C1, and with the thumb and forefinger grasp the condenser and pull. The chassis will separate from the tuning knob which is left attached to the cabinet front.

TO REMOVE THE CLOCK

Separate the cabinet as described above. Unsolder the two leads, one from the switch to the circuit board and one from the clock motor to the circuit board. Remove the two screws holding the AC interlock to the cabinet. Remove the two clock knobs. Snap out the clock crystal starting from the left side. Then, remove the two nuts holding the clock to the cabinet and remove the clock.

TROUBLESHOOTING

Excessive loudness when adjusting the volume level to minimum is caused by excessive capacity between terminals 2 and 3 of RCW-3207. The excessive capacity can be eliminated without replacing the couplate or by removing the circuit board in the following manner:

1. Clip off couplate lead #3.
2. Solder a 220 mmf. capacitor (Cat. No. RS-1203) across the two outside terminals of the volume control, located on the component side of the chassis board.

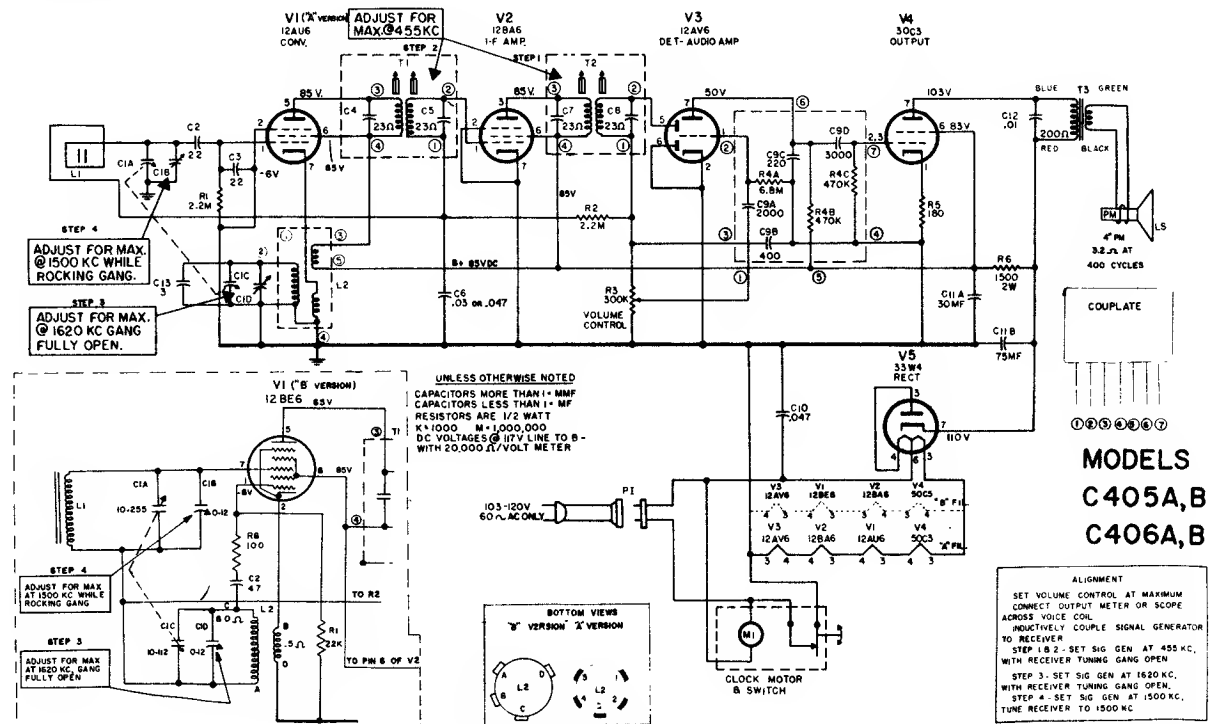

GENERAL ELECTRIC COMPANY

Model C435A

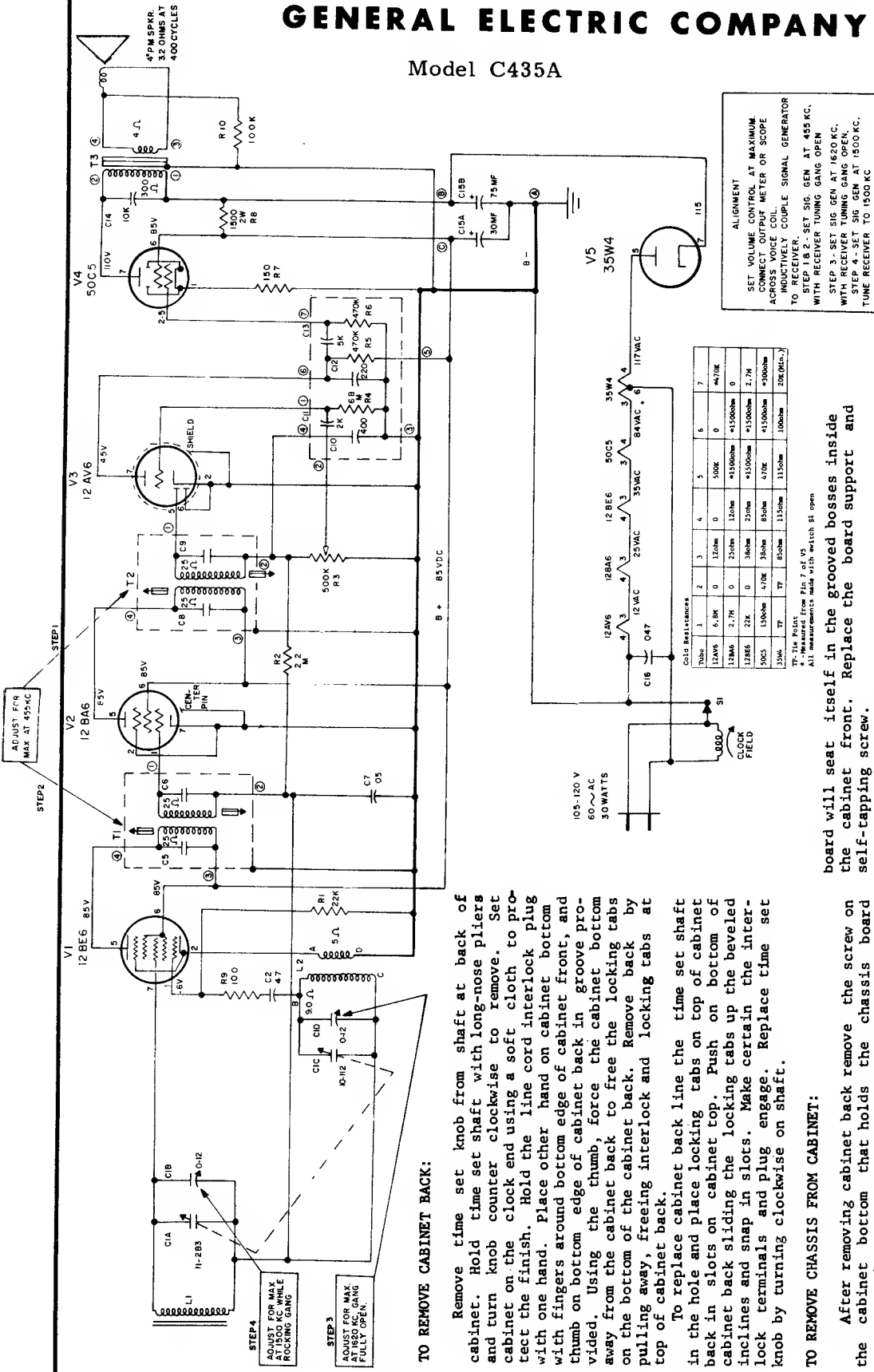

ALIGNMENT
 SET VOLUME CONTROL AT MAXIMUM
 CONNECT OUTPUT METER OR SCOPE
 ACROSS VOICE COIL.
 INDUCTIVELY COUPLE SIGNAL GENERATOR
 TO RECEIVER.
 STEP 1 B 2 - SET SIG. GEN AT 455 KC.
 WITH RECEIVER TUNING GANG OPEN.
 STEP 3 - SET SIG. GEN AT 1620 KC.
 WITH RECEIVER TUNING GANG OPEN.
 TUNE RECEIVER TO 1500 KC.

UNLESS OTHERWISE DENOTED
 CAPACITORS MORE THAN 1 μmf
 CAPACITORS LESS THAN 1 μmf
 RESISTORS - K=1,000
 -M=1,000,000
 DC VOLTAGES AT HTV LINE TO B-
 W/20,000 Ω/VOLT METER

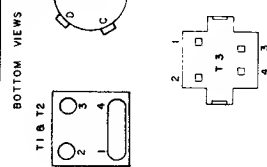

GOLD RESISTANCES

Tube	1	2	3	4	5	6	7
12AV6	6.8K	0	120Ω	0	500K	0	∞/7K
12BA6	2.7K	0	250Ω	120Ω	∞/1500Ω	∞/1500Ω	0
12BE6	22K	0	360Ω	250Ω	∞/1500Ω	∞/1500Ω	2.7M
50C5	1500Ω	∞/7K	360Ω	85Ω	∞/7K	∞/1500Ω	∞/300Ω
35W4	TP	TP	250Ω	115Ω	100Ω	20K (Min.)	

TP - Test Point
 ∞ - Infinite Impedance
 All measurements made with switch S1 open

board will seat itself in the grooved bosses inside the cabinet front. Replace the board support and self-tapping screw.

TO REMOVE VOLUME CONTROL:
 The volume control is attached to the cabinet and may be removed by pulling the knob straight off and removing the palmnut.
 When replacing the volume control place the tab on the control in the groove provided.

TO REMOVE SPEAKER:
 After removing the chassis board remove four tubular speaker clips and lift the speaker out of the cabinet.

TO REMOVE CABINET BACK:

Remove time set knob from shaft at back of cabinet. Hold time set shaft with long-nose pliers and turn knob counter clockwise to remove. Set cabinet on the clock end using a soft cloth to protect the finish. Hold the line cord interlock plug with one hand. Place other hand on cabinet bottom with fingers around bottom edge of cabinet front, and thumb on bottom edge of cabinet back in groove provided. Using the thumb, force the cabinet bottom away from the cabinet back to free the locking tabs on the bottom of the cabinet back. Remove back by pulling away, freeing interlock and locking tabs at top of cabinet back.

To replace cabinet back line the time set shaft in the hole and place locking tabs on top of cabinet back in slots on cabinet top. Push on bottom of cabinet back sliding the locking tabs up the beveled inclines and snap in slots. Make certain the interlock terminals and plug engage. Replace time set knob by turning clockwise on shaft.

TO REMOVE CHASSIS FROM CABINET:

After removing cabinet back remove the screw on the cabinet bottom that holds the chassis board support. The tuning knob is a captive knob and remains in the cabinet front. Close the tuning gang to prevent any possible damage to the plates. Slide one hand under the printed chassis board placing the fingers over the front edge. Slide the board back out of the grooves on either end simultaneously removing the tuning gang shaft from the tuning knob. When replacing the chassis, close the tuning gang and line the flat side of the tuning gang shaft up with the flat in the tuning knob. Place the end of the board in the grooves and push on the edge of the board, not on the components. The tuning shaft will enter the tuning knob and the front edge of the



GENERAL ELECTRIC COMPANY

Models C440A and C441A

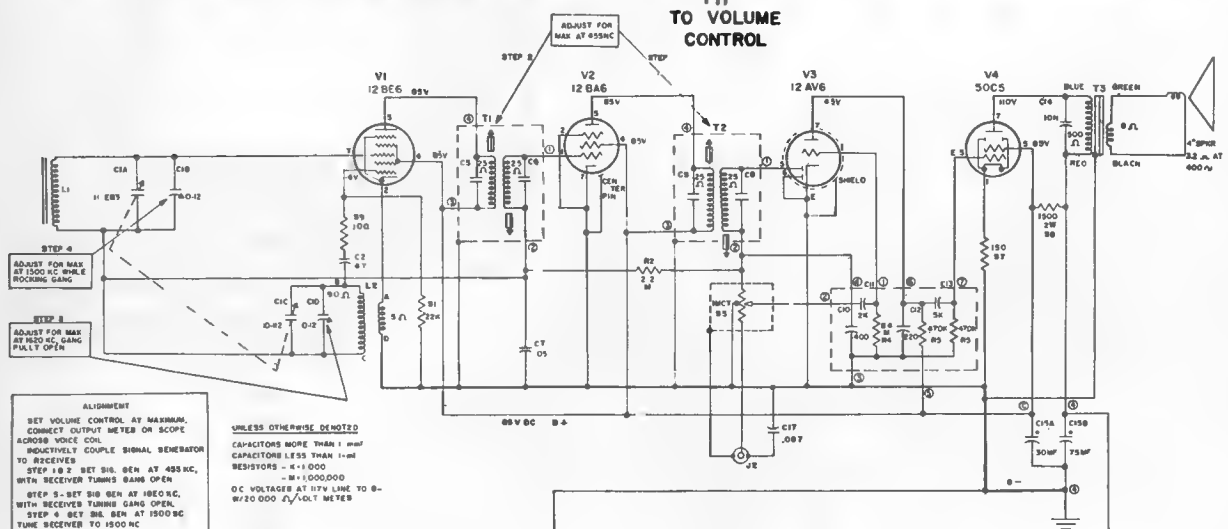
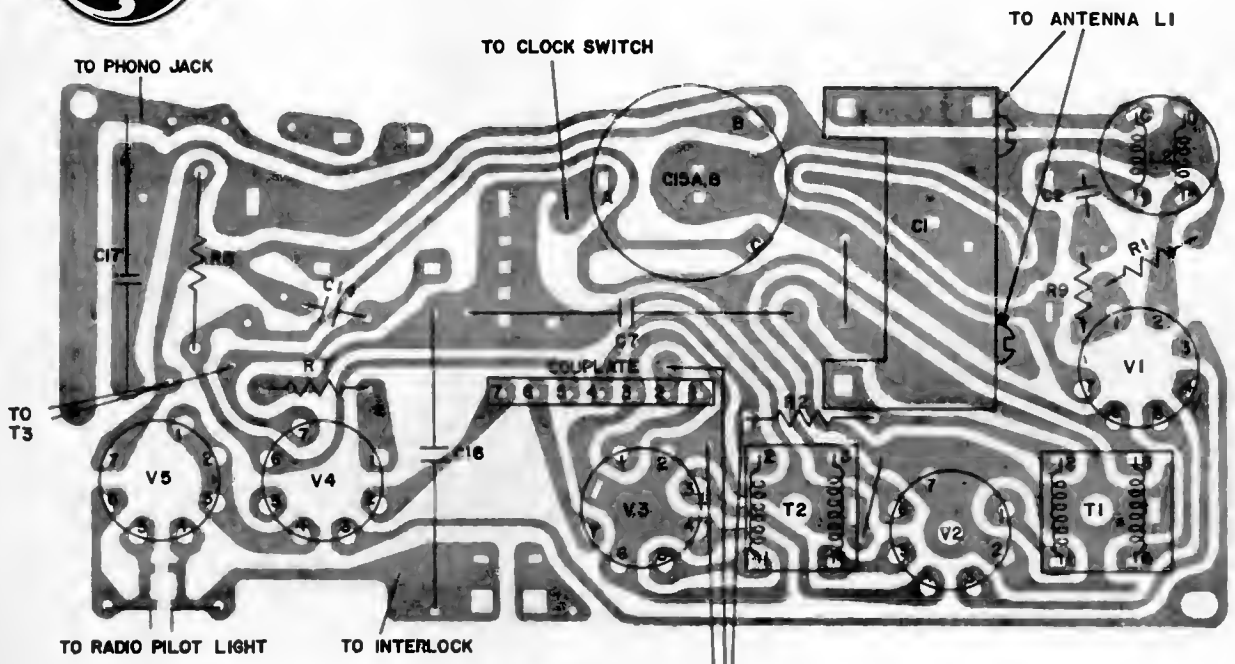

Tube Pin Resistance Chart

Tube	1	2	3	4	5	6	7
12AV6	6.8M	0	15	0	500K	0	*470K
12BA6	2.7M	0	25	15	*1500ohm	*1500ohm	0
12BE6	22K	0	35	25	*1500ohm	*1500ohm	2.7M
50C5	150ohm	470K	35	80	470K	*1500ohm	*300ohm
35W4	TP	TP	80	110	105	105	20% (min.)

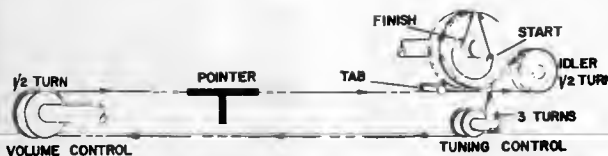

TP-Tie Point
 * Measured from Pin 7 of V5
 Resistances measured with pilot light (Mazda # 12) in socket
 All measurements taken with respect to 3- unless otherwise designated.

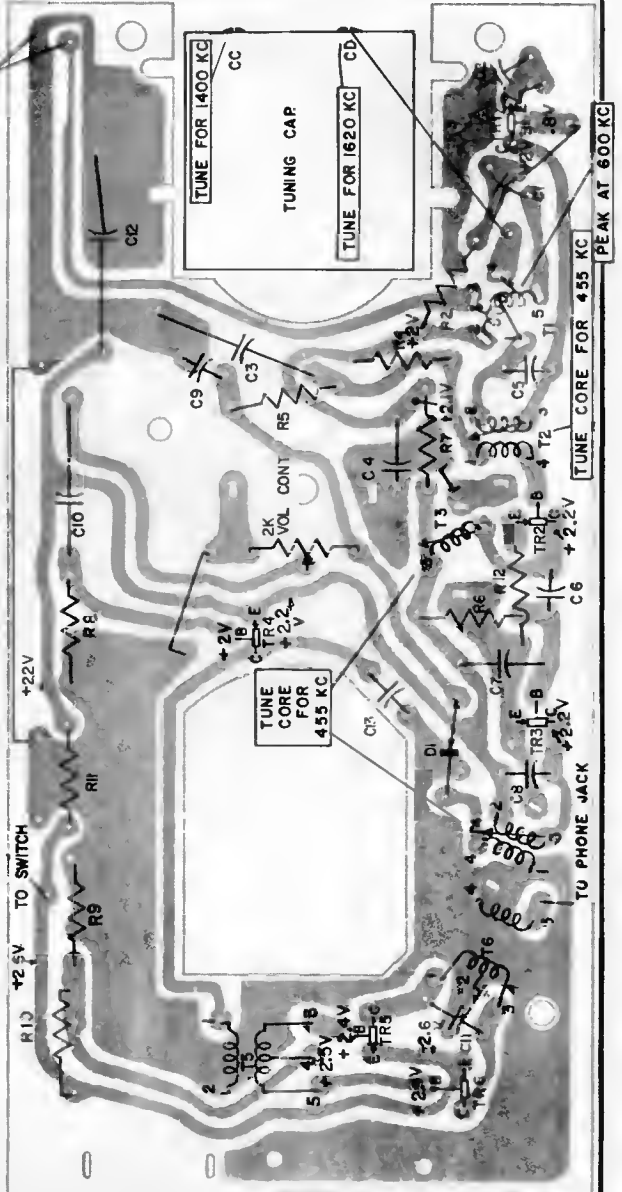
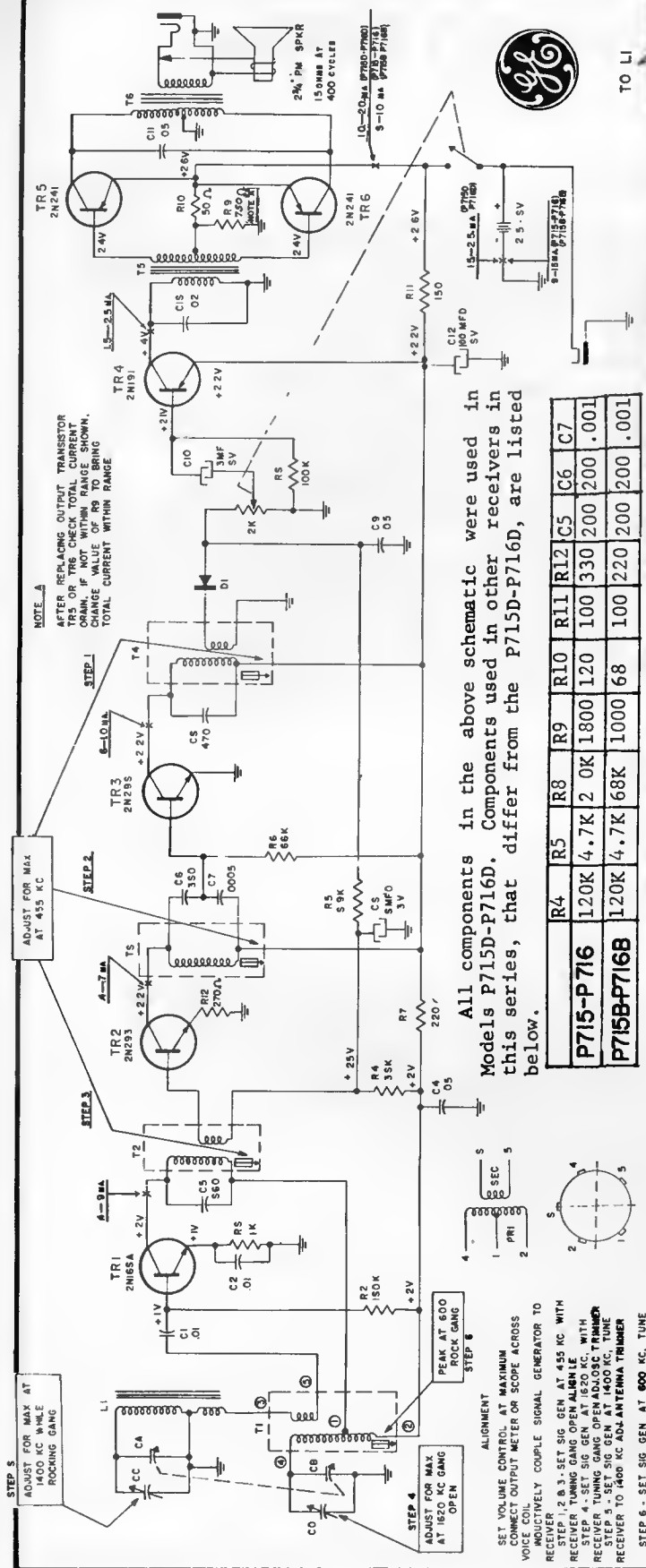

GENERAL ELECTRIC

MODELS
P715-P716
P715B-P716B
P715D-P716D

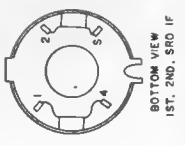

GENERAL ELECTRIC

MODELS
P725B
P726B

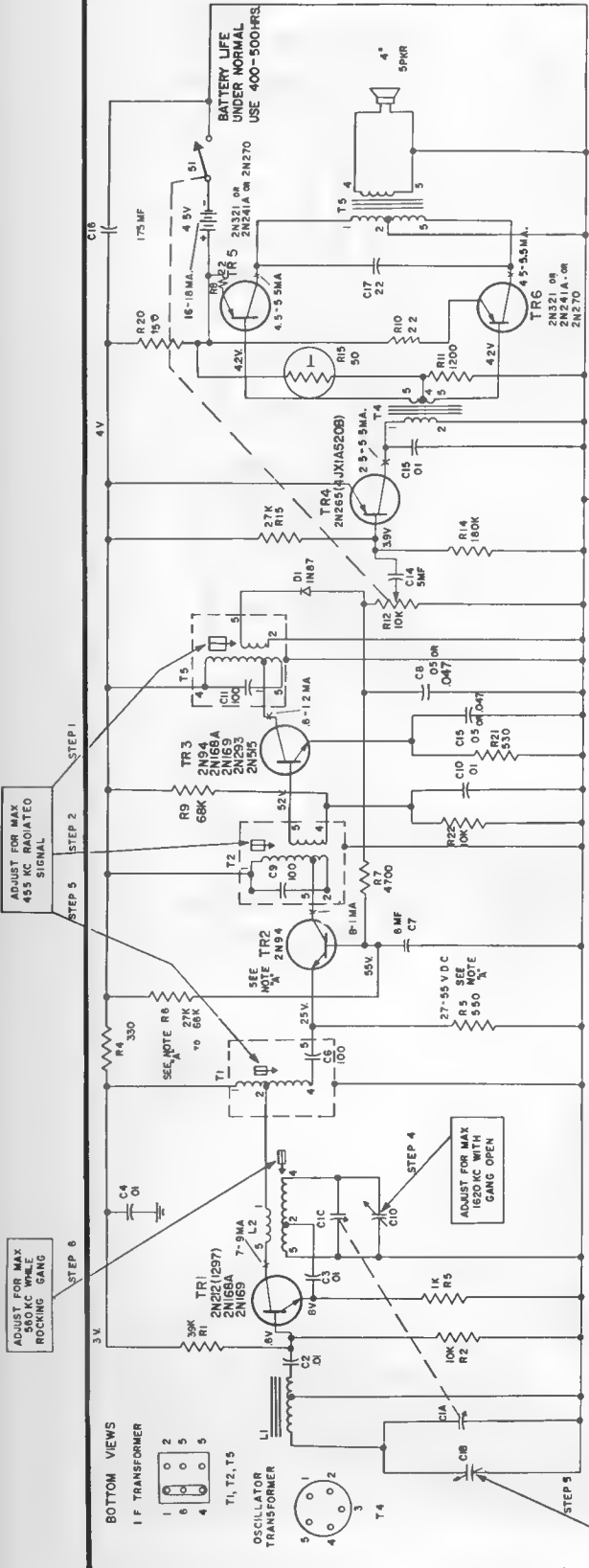

MEASURE COLLECTOR CURRENTS WITH A MILLIAMMETER INSERTED IN SERIES WITH THE CIRCUITS MARKED "A" AND ALSO MEASURE BATTERY CURRENT BY INSERTING METER LEADS IN SERIES WITH BATTERIES

NOTE "A" AFTER REPLACING TR2, CHECK VOL. TAGE ACROSS RA IF NOT WITHIN RANGE, CHANGE VALUE OF R6 UNTIL VOLTAGE ACROSS R5 IS WITHIN VOLTAGE RANGE SHOWN

UNLESS OTHERWISE NOTED—ADJUST FOR MAX 1500 KC WHILE ROCKING GANG CAPACITORS MORE THAN 1-1/2 MF CAPACITORS LESS THAN 1-1/2 MF RESISTORS ARE 1/2 WATT * = 1000

VOLTAGES ARE POSITIVE WITH RESPECT TO GROUND

ALIGNMENT SET VOLUME CONTROL AT MAXIMUM CONNECT OUTPUT METER OR SCOPE ACROSS VOICE COIL. CAREFULLY COUPLE SIGNAL GENERATOR TO RECEIVER STEP 1, 2 & 3—SET SIG GEN AT 455 KC, WITH RECEIVER TUNING GANG OPEN STEP 4—SET SIG GEN AT 1620 KC, WITH RECEIVER TUNING GANG OPEN STEP 5—SET SIG GEN AT 1500 KC, TUNE RECEIVER TO 500 KC STEP 6—SET SIG GEN AT 580 KC, TUNE RECEIVER TO 580 KC

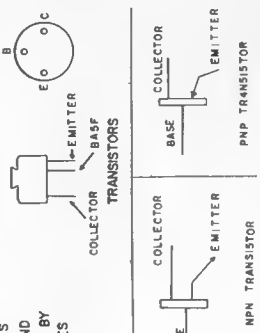

TROUBLESHOOTING

A check of battery condition and total current drain of the receiver should be made first. All current measurements are made at quiescence with the receiver turned on, volume control at maximum, tuning gang closed, and with no signal conditions. The total receiver current drain is 16 to 18 mils. This is measured by inserting a milliammeter in series with the batteries. If an excessive total current drain is recorded, the individual collector currents of each transistor should be checked. An excessive current reading may mean a shorted transistor; no current will indicate that a transistor or associated circuit component is defective.

A single-edge razor blade is a satisfactory tool for cutting the copper circuit wiring so that a milliammeter can be inserted in series with the break to measure the current flow. After each current check is completed, solder the cut carefully to complete the circuit again.

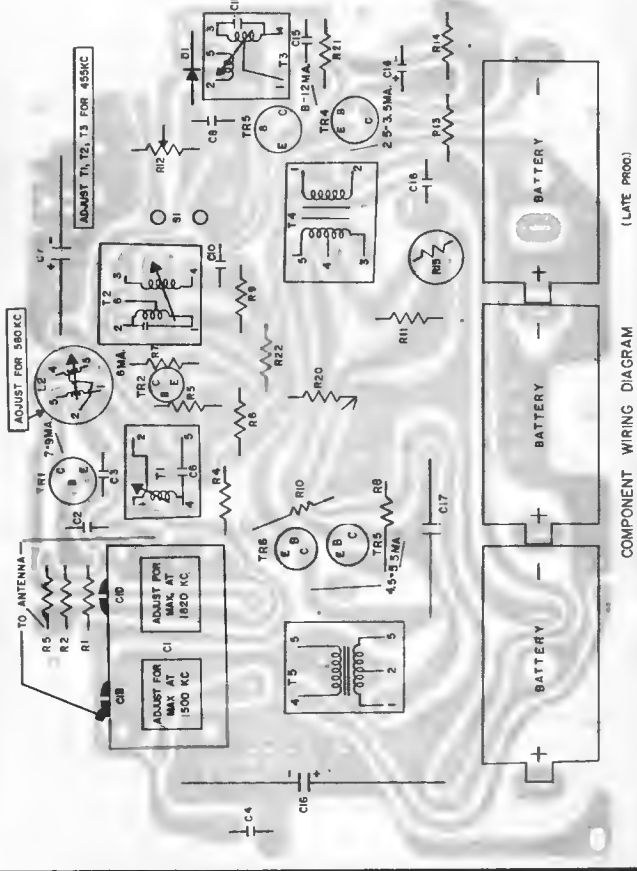

COMPONENT WIRING DIAGRAM (LATE PROG)

GENERAL ELECTRIC

MODELS
P735A
P736A

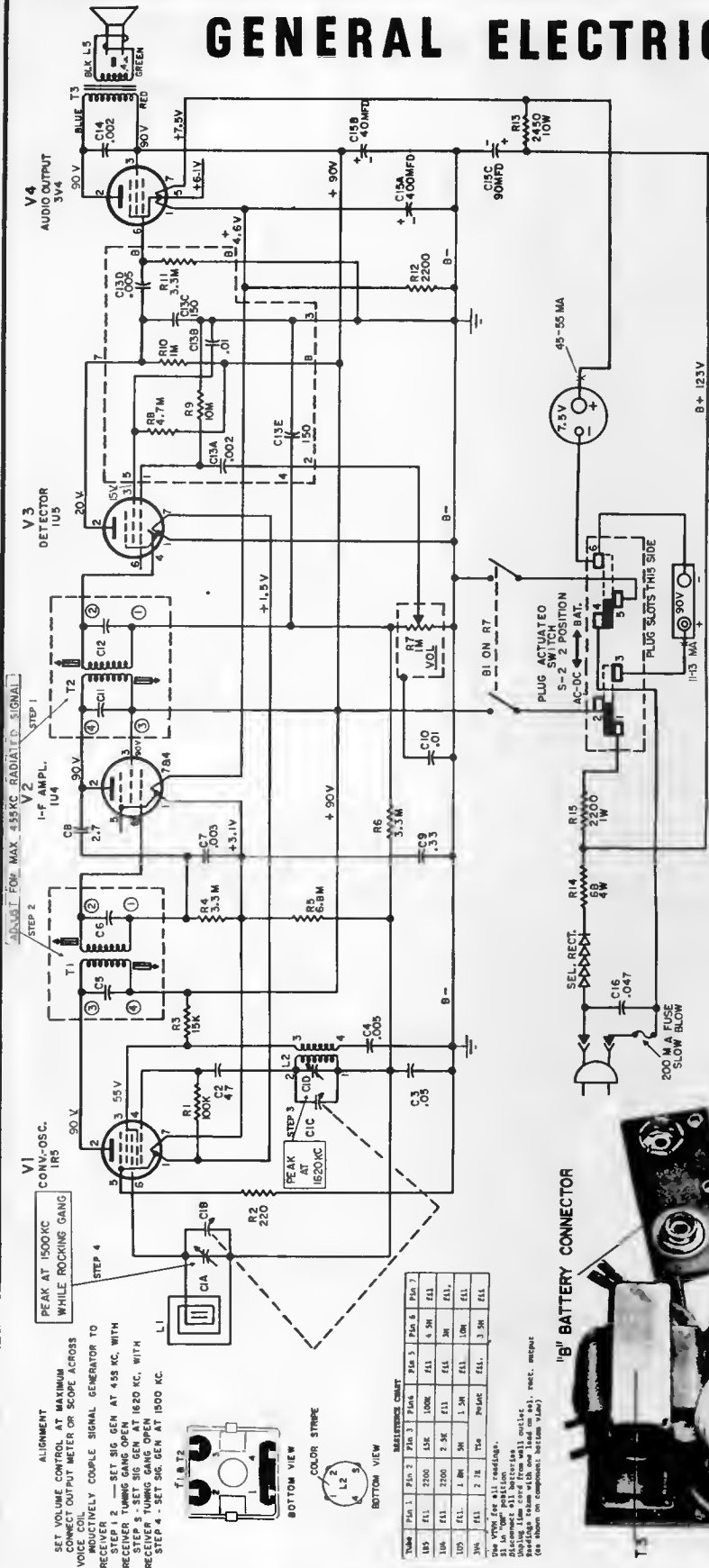

OPERATING FREQUENCIES:	Tuning range	540-1600 KC
AUDIO POWER OUTPUT:	I-F Amplifier.....	455 KC
	Maximum -	250-300 Milliwatts

UNLESS OTHERWISE NOTED
K=1,000 M=1,000,000
CAPACITORS MORE THAN 1-M.F.
CAPACITORS LESS THAN 1-M.F.
RESISTORS ARE 1/2 WATT

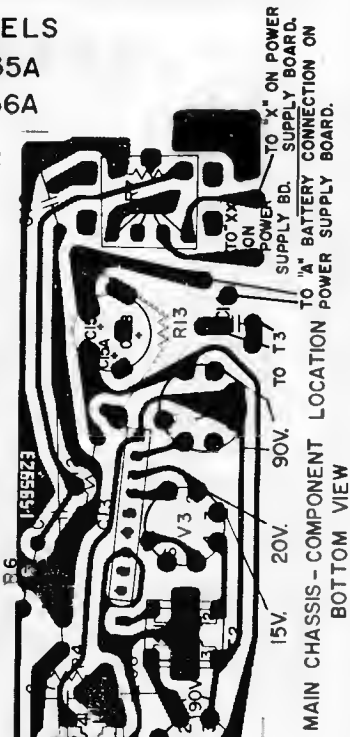

MAIN CHASSIS - COMPONENT LOCATION
BOTTOM VIEW

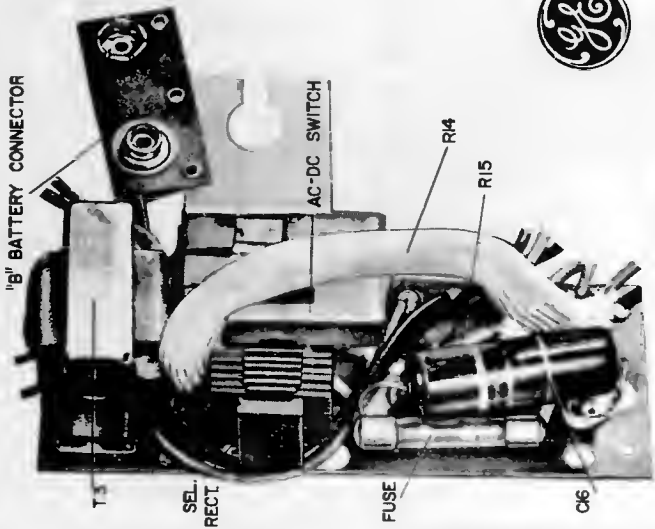

POWER CHASSIS TOP VIEW



ALIGNMENT
SET VOLUME CONTROL AT MAXIMUM
CONNECT OUTPUT METER OR SCORE ACROSS
VOICE COILS TO RECEIVE SIGNAL GENERATOR TO
RECEIVER
STEP 1 2 - SET SIG. GEN. AT 455 KC. WITH
RECEIVER TUNING GANG OPEN AT 1620 KC. WITH
RECEIVER TUNING GANG OPEN
STEP 4 - SET SIG. GEN. AT 1800 KC.



Tube	Pin 1	Pin 2	Pin 3	Pin 4	Pin 5	Pin 6	Pin 7
1L5	EL1	2500	150K	1000K	EL1	4.5M	EL1
1L6	EL1	2500	2.5K	EL1	EL1	3M	EL1
1D5	EL1	1.8M	5M	1.5M	EL1	10M	EL1
1L7	EL1	2.7K	10M	EL1	EL1	3.5M	EL1

RESISTOR COLOR CODINGS
1st and 2nd digits in white, 3rd in black
4th and 5th digits in black
6th digit in red
7th digit in blue
8th digit in green
9th digit in yellow
10th digit in brown
11th digit in purple
12th digit in orange
13th digit in pink
14th digit in light blue
15th digit in light green
16th digit in light yellow
17th digit in light purple
18th digit in light orange
19th digit in light pink
20th digit in light blue

GENERAL ELECTRIC

Models P755A, P805, and P806

TRANSISTOR CHART

TR1*	TR2	TR3	TR4	TR5
2N194A	2N135	2N169	2N192	2N241A
2N212		2N233A	2N324	2N270
(1297)		2N293	2N406	2N321
		2N314		2N408

*When TR1 is 2N169, resistor R1 is 82K.
When 2N212(1297) is used, R1 is 33K.

TO REMOVE CIRCUIT BOARD

1. Remove screw from the cabinet back.
2. Insert a coin in either slot on the cabinet bottom and twist to remove the cabinet back.
3. Remove screw holding tuning dial.
4. Remove 3 screws under tuning dial to release tuning gang from cabinet front.
5. Remove 3 hexhead screws and one 11/32" nut (bottom center of circuit board) holding circuit board to bosses on cabinet front.
6. Fold tuning gang and circuit board out of cabinet front toward the volume control end. It is not necessary to remove volume control to repair the circuit board.

TO REMOVE VOLUME CONTROL

1. Remove cabinet back.
2. Remove hex head screw from center of volume control knob.
3. Remove chassis.
4. Remove pal nut holding volume control to cabinet front boss.

TO REMOVE SPEAKER

1. Remove cabinet back.
2. Remove chassis.
3. Unsolder speaker wires.
4. Remove clips holding speaker to cabinet front.

TROUBLE SHOOTING

A check of battery current drain will indicate if a receiver is operating properly. To measure the current drain, remove cabinet back, unsnap ground section of battery terminal and swing away from battery. Connect milliammeter between battery terminal and battery contact.

The total current drain should be between 19.0 and 24.0 ma. The current drain is measured with no-signal-conditions (tuning gang closed) and volume control at maximum.

If an excessive current drain is recorded, the individual collector current readings should be checked on each transistor. Current drain is an important indication of the transistor operating conditions.

ALIGNMENT
SET VOLUME CONTROL AT MAXIMUM.
CONNECT OUTPUT METER OR SCOPE ACROSS TUNING GANG AND TUNE TO RECEIVER.
STEP 1 & 2 - SET SIG. GEN. AT 455 KC. WITH RECEIVER TUNING GANG OPEN.
STEP 3 - SET SIG GEN AT 1620 KC. WITH RECEIVER TUNING GANG OPEN. TUNE RECEIVER TO 800 KC

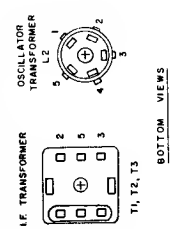

UNLESS OTHERWISE NOTED - ALL CAPACITORS ARE LESS THAN 1 MF. RESISTORS ARE 1/2 WATT K-1.0000
MEASURE COLLECTOR CURRENTS WITH A MILLIAMMETER INSERTED IN SERIES WITH THE CIRCUITS MARKED "X" AND ALSO BATTERY CURRENT AT POINT MARKED "X" IN THE BATTERY CIRCUIT.
*WHEN TR1 IS 2N169
*WHEN TR1 IS 2N212
*C7 IS DELETED
*R1 IS REPLACED BY A JUMPER

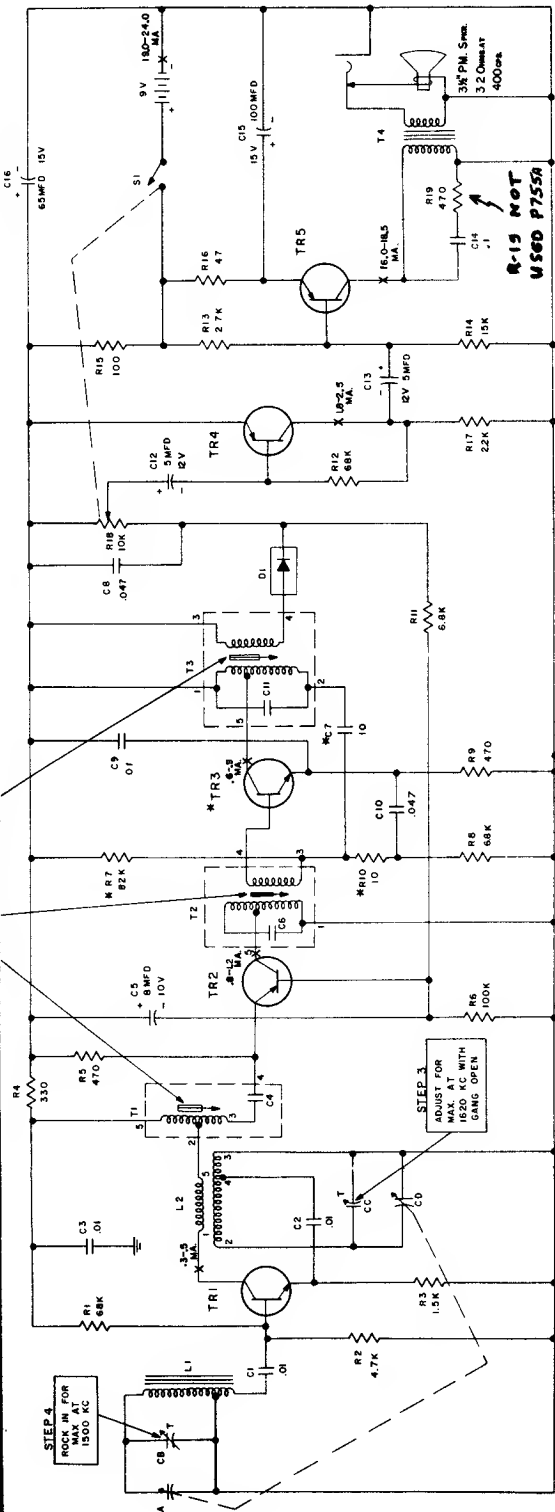

GENERAL ELECTRIC COMPANY

Models P671A,B, P672A,B, P673A,B, P674B

SPECIFICATIONS

CABINETS: (Plastic)	Models P671A,B - Black and White Models P672A,B - White and Terra Cotta Models P673A,B - Turquoise and White Model P674B - Green
ELECTRICAL RATING:	105-120 Volts A-C (50 to 60 cycles) or DC 1 "A" battery - 7 1/2 volt Eveready No. 717 or equivalent 1 "B" Battery - 90 Volt Eveready No. 479 or equivalent
OPERATING FREQUENCIES:	Tuning range 540-1600 KC I-F 455 KC

CHASSIS REMOVAL:

The chassis is easily removed by means of the following procedure:

1. Swing down cabinet front by grasping front at top edge under handle.
2. Remove tuning and volume control knobs by pulling straight off their shafts.
3. Remove the two small Phillips-head screws from the top rear edge of the metal chassis mounting bracket.
4. Slide chassis and bracket out of cabinet.
5. Remove bracket from chassis by unscrewing the 1/4" mounting screw from the bracket.

The power supply chassis is removed from the cabinet by removing the four small hex-head mounting screws.

The speaker is mounted on the cabinet front and may be removed by taking off the four speaker mounting clips which secure the speaker to the four bosses on the inside of the cabinet front.

IMPORTANT: Use care when replacing defective parts. Apply as little heat to terminals and connections as possible to remove parts, as excessive heat will damage the plated wiring on the chassis boards.

When replacing knobs, do not force them on, as too much pressure may cause circuit board to bend and crack.

VOLUME CONTROL REPLACEMENT:

The chassis must first be removed from the cabinet as described under CHASSIS REMOVAL, then replace volume control as follows:

1. Cut off the three control lugs and the four on-off lugs.
2. Heat the remaining part of the lugs on the circuit board and pull out with long-nose pliers.
3. Clean all mounting holes of all excess solder.
4. The volume control on-off switch (catalog no. RRC-367) is used as the replacement. This control has a combined mounting bracket which can be mounted with the control on the circuit board. There are four holes on the board in which the mounting bracket can be inserted and soldered on the dip-soldered side of the circuit board.

TO REPLACE A TUBE SOCKET:

Cut the socket free by cutting all of the socket terminals at the chassis. One socket (V2) has a center terminal which must be unsoldered. Now, heat the pieces of terminals remaining in the board only enough so they may be pushed out. The new socket can now be inserted into the holes left by the old one and soldered into place.

BATTERY INSTALLATION:

Insert batteries in place as shown in the Tube and Battery location illustration. Make sure the battery connections are well seated.

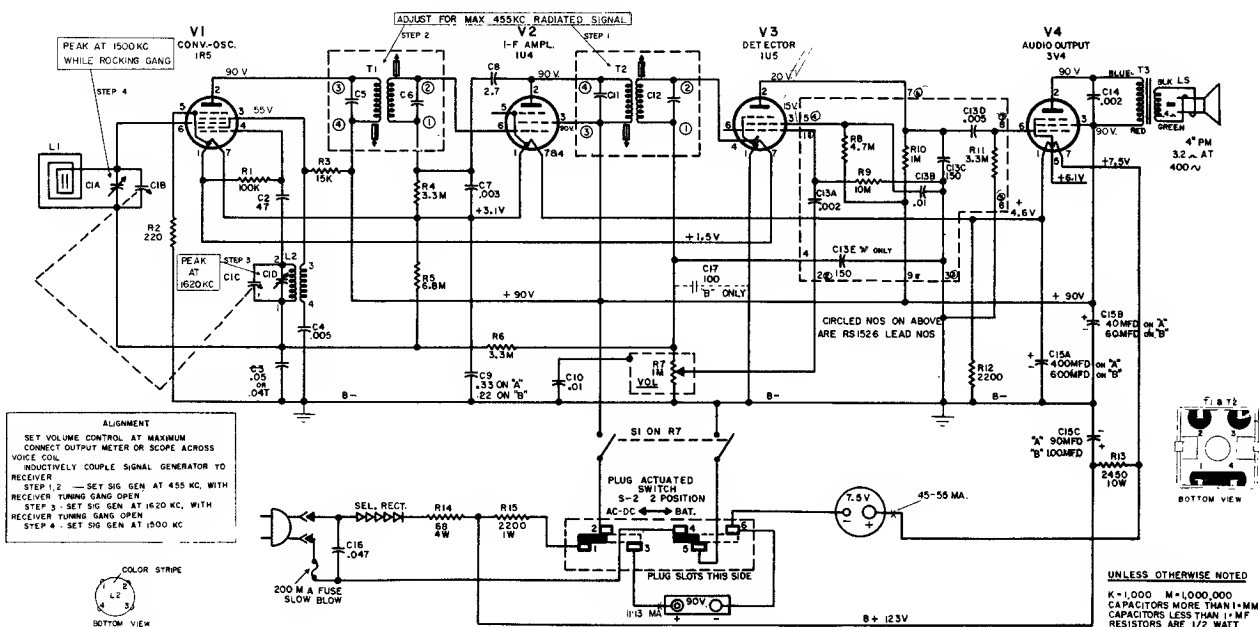

GENERAL ELECTRIC COMPANY

Model RP1110A

SPECIFICATIONS

ELECTRICAL RATING:	105-120 Volts 60 Cycle AC 45 Watts
POWER OUTPUT:	Undistorted: 1.5 Watts Maximum: 2 Watts
RECORD CHANGER:	Model CH10 four speed automatic with 90 Volt AC motor
PHONOGRAPH PICK-UP:	Dual Sapphire Stylus Astatic 81T or equivalent

TROUBLESHOOTING

The tube filaments and changer motor are connected in series. An open filament in an amplifier tube will prevent the operation of the changer motor. Be sure the tubes are operating properly before troubleshooting changer.

The input AC voltage rating of the changer is 90 volts. When testing a changer disconnected from amplifier, a 100 ohm 10 watt resistor may be used as a substitute in place of tube filaments, or a variac set at 90 volts must be inserted between changer and power line. Do not plug changer into a 105-120 volt outlet.

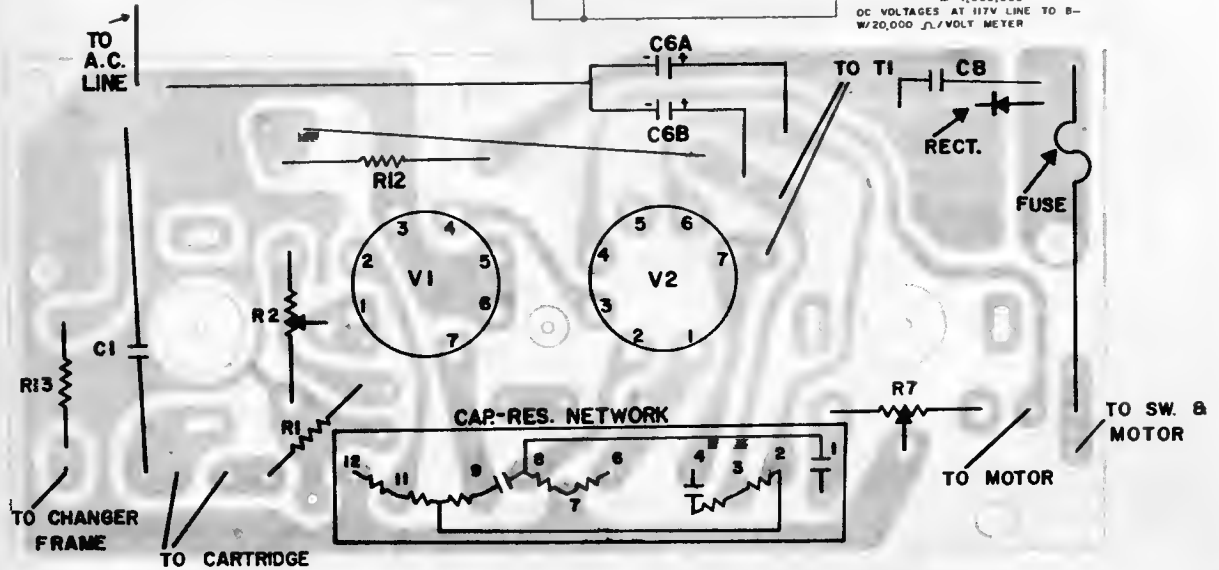
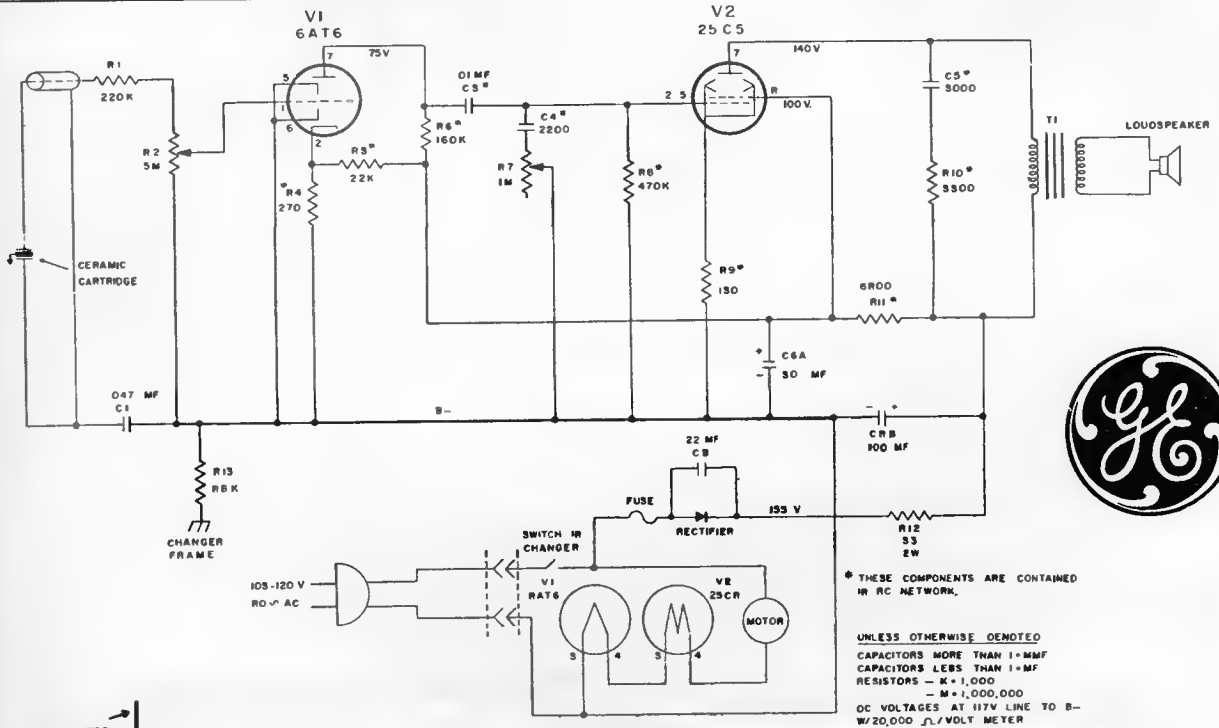

COMPONENT LOCATIONS - BOTTOM VIEW - RP-1110A

GENERAL ELECTRIC COMPANY Models RP1120A, RP1120B

TO REPLACE TUBES

1. Open cabinet lid.
2. Remove screws holding vent panel board and interlock.
3. Remove vent panel board (interlock is automatically disconnected.)

TO REMOVE AMPLIFIER CHASSIS

1. Follow steps 1 through 3 as above.
2. Remove loudness and tone knobs.
3. Loosen screws on interlock bracket; slide interlock out of mounting slot. (Mark location of bracket on cabinet before removing so that bracket can be "keyed" to correct location when replacing.)

4. Remove the three hexhead nuts from screws on cabinet brace above speakers and the three hexhead nuts from screws on cabinet brace under speakers.
5. Lift out grille (with all electronic components) and place down in front of cabinet carefully.
6. Unscrew two clamps holding wires from chassis to changer.
7. Remove amplifier chassis by unscrewing the three screws holding chassis to grille.
Before replacing knobs, turn control shafts fully counterclockwise; press on knobs with the knob indicator dot to the left of center at the bottom.

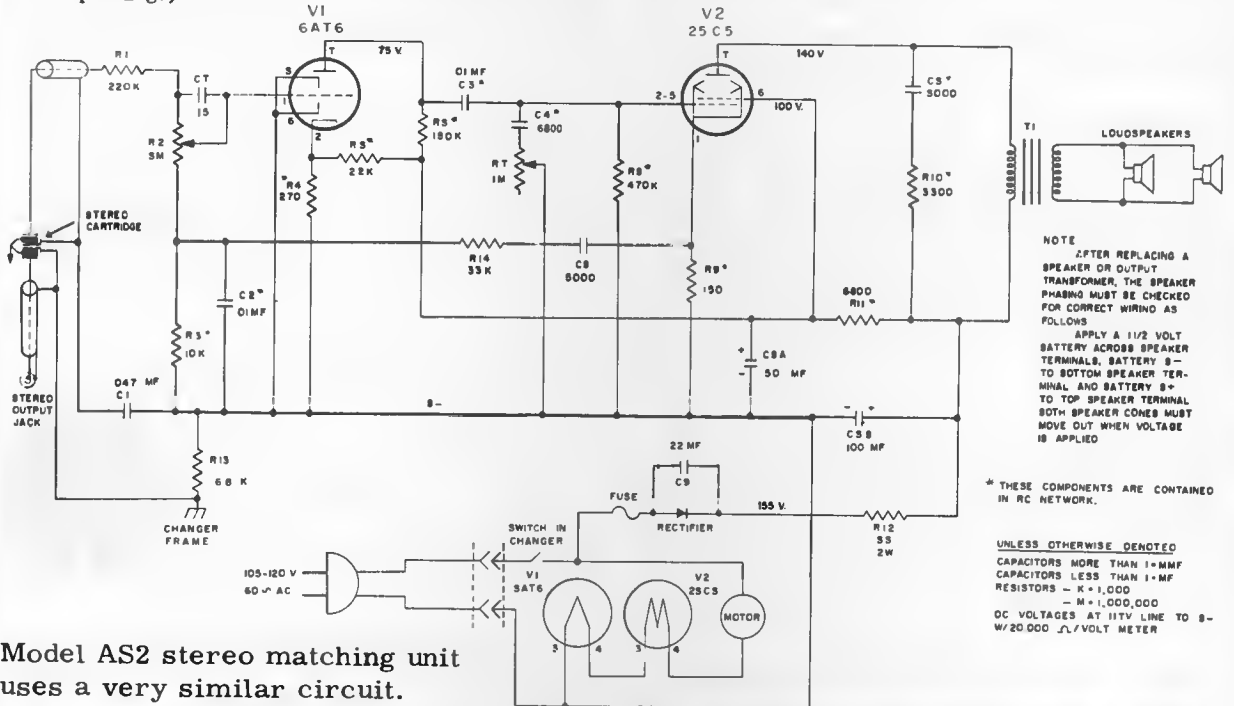

Model AS2 stereo matching unit uses a very similar circuit.

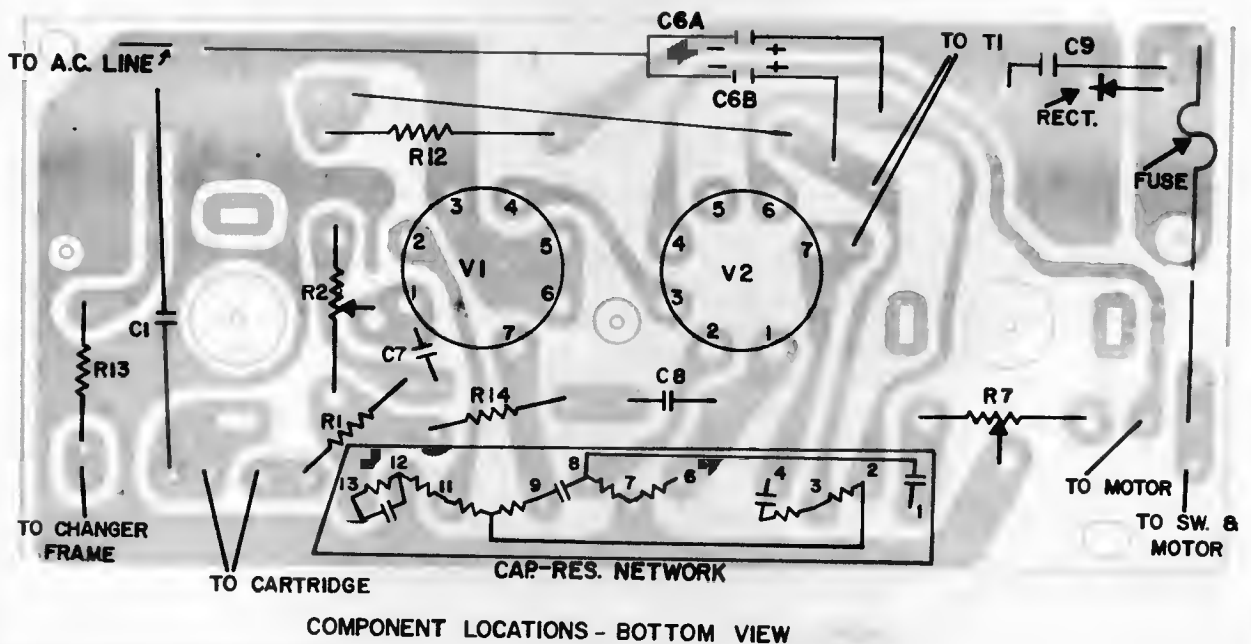

GENERAL ELECTRIC

RADIO/PHONO
MODEL
RP1160A

PHASING NOTE:
PLACE 15 VOLT BATTERY
ACROSS SPEAKERS
INDICATED. POINT
MOVES INWARD

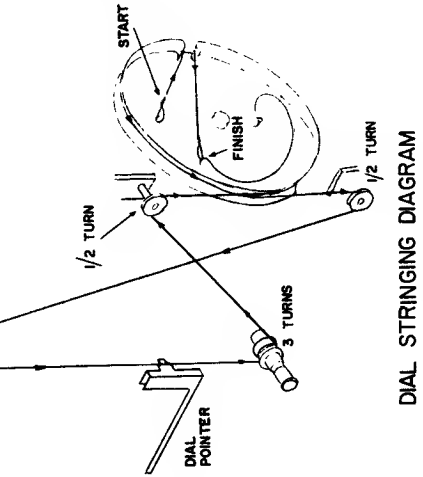
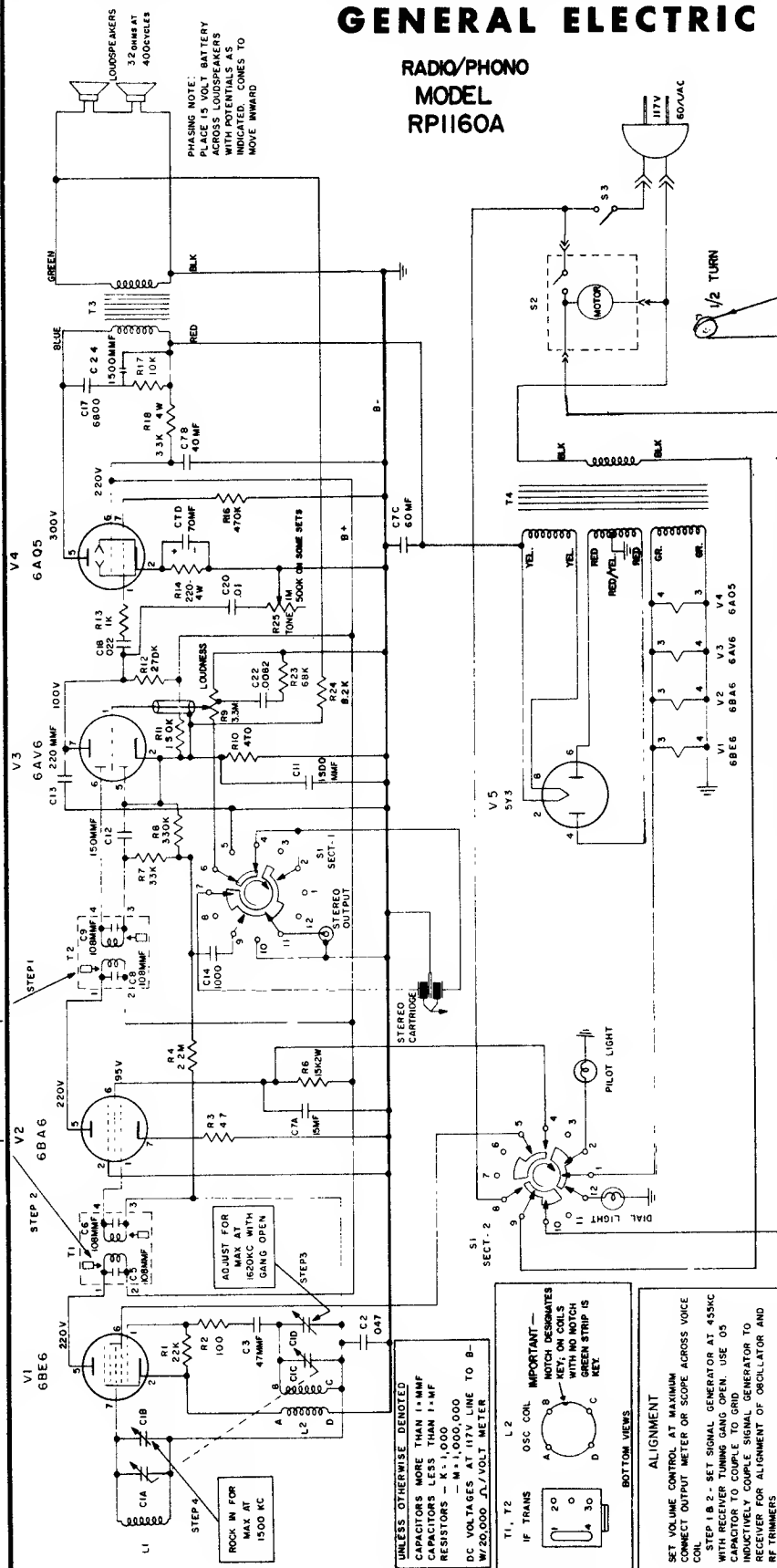

DIAL STRINGING DIAGRAM

6. Remove grille by sliding out and down from bottom, be careful not to break speaker and antenna wires.
7. Remove compartment light from antenna bracket.
8. Remove antenna screws from top and bottom of metal chassis front plate. (It is not necessary to remove plastic dial assembly from chassis front plate.)
10. Turn clips on bottom of the shipping screws parallel to the screws.
11. Lift record changer free of mounting board.
12. Remove screw holding electrolytic.
13. Disconnect plug.
14. Unsolder and label the shielded signal wires (that go to the Stereo-Mono-Radio switch) from the terminal board on bottom of changer.
15. Loosen nuts holding power transformer mounting plate and slide chassis, electrolytic, antenna and compartment light out the front.

- TO REPLACE TUBES**
1. Open cabinet lid.
 2. Remove screws holding vent panel cover and interlock.
 3. Remove vent panel cover (interlock is automatically disconnected.)
- TO REMOVE CHASSIS**
1. Follow steps 1 through 3 as above.
 2. Remove knobs.
 3. Remove screws holding ventilated speaker compartment panel, remove panel.
 4. Remove screws holding interlock connector.
 5. Remove screws (holding grille bottom and chassis) from bottom of cabinet.

ADJUST FOR MAX. 455KC RADIATED SIGNAL

ADJUST FOR MAX AT 1620KC WITH GANG OPEN

ROCK IN FOR MAX AT 1500 KC

UNLESS OTHERWISE DENOTED CAPACITORS MORE THAN 1µMUF ARE ELECTROLYTIC. RESISTORS - M=1,000,000 - M=1,000,000 DC VOLTAGES AT 117V LINE TO B-W/20,000 Ω/VOLT METER

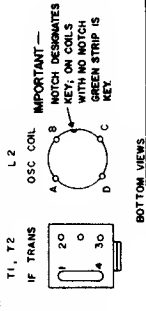

ALIGNMENT
SET VOLUME CONTROL AT MAXIMUM. CONNECT OUTPUT METER OR SCOPE ACROSS VOICE COIL.
STEP 1 B-2 - SET SIGNAL GENERATOR AT 455KC WITH RECEIVER TUNING GANG OPEN. USE OSC GENERATOR TO COUPLE SIGNAL TO RECEIVER FOR ALIGNMENT OF OSCILLATOR AND RF TRIMMERS.
STEP 3 - SET SIGNAL GENERATOR AT 1620KC WITH RECEIVER TUNING GANG OPEN.
STEP 4 - SET SIGNAL GENERATOR AT 1500KC. TUNE RECEIVER TO 1500KC ON DIAL. (SEE ABOVE STEPS)

GENERAL ELECTRIC

Models AS15A and AS16A

SPECIFICATIONS

CABINET:	AS15A - Mahogany AS16A - Blond Oak
ELECTRICAL RATING:	105-120 volts 60 cycles AC 75 watts
POWER OUTPUT:	Maximum 10 watts 10% Distortion 8 watts

TO REMOVE CHASSIS FROM CABINET

1. Remove cabinet back.
2. Remove two screws holding chassis to cabinet.
3. Unscrew clamps holding connecting wires and remove screws holding electrolytic condenser and output transformer.
4. Pull pilot light holder off bracket.
5. Remove Chassis.

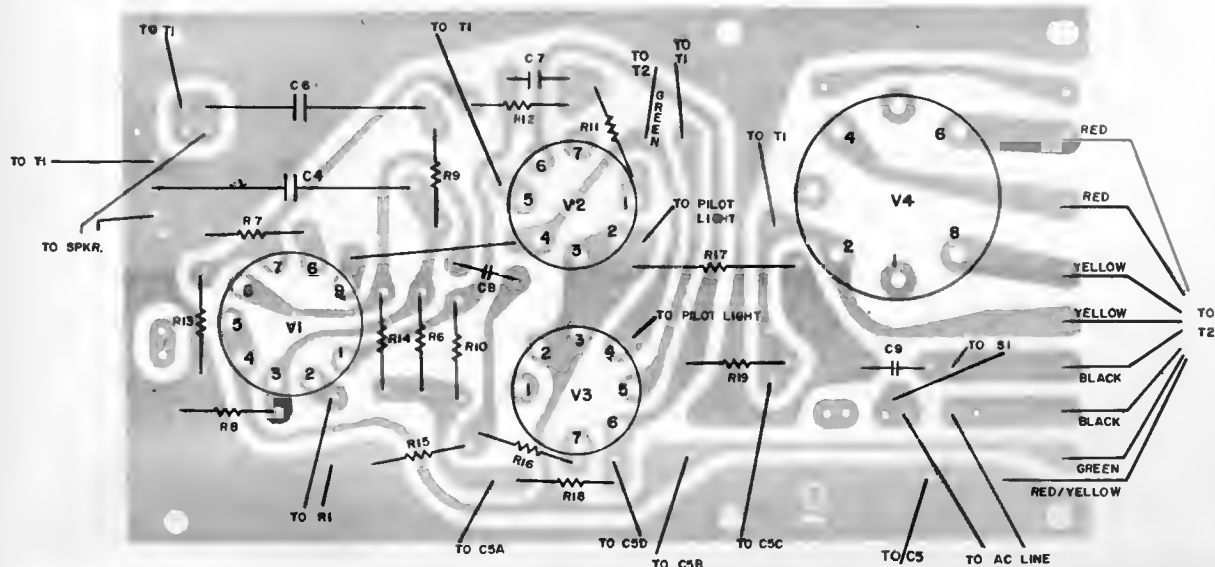
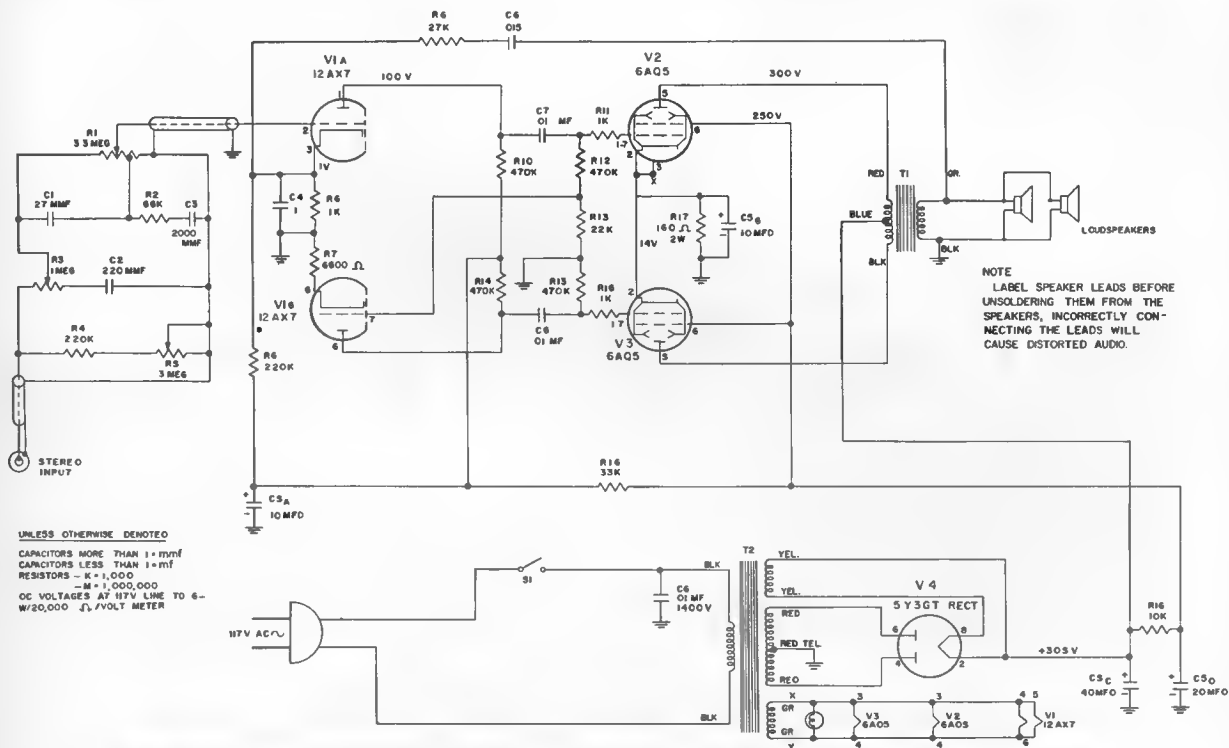

GRANCO PRODUCTS INC. MODEL 601 FM RADIO

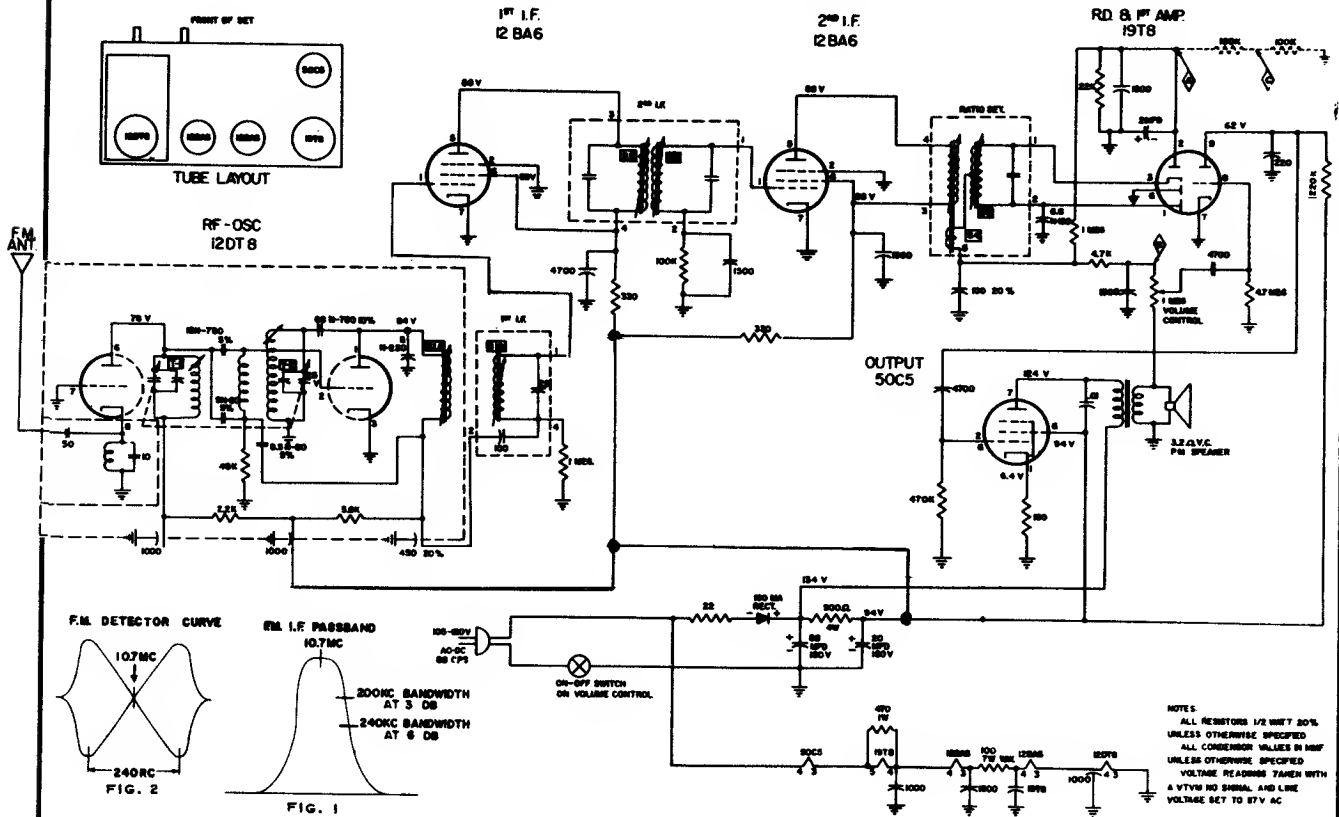

NOTES:
ALL RESISTORS 1/2 WATT 20%
UNLESS OTHERWISE SPECIFIED
ALL CONDENSERS 50V 50%
UNLESS OTHERWISE SPECIFIED
VOLTAGE READINGS TAKEN WITH
A VTVM NO SIGNAL AND LINE
VOLTAGE SET TO 87 V AC

NOTE #1 - To remove chassis from cabinet, place receiver face down on flat surface. Remove bottom screw and proceed to remove rear portion of cabinet by slapping sides of cabinet with palm of hands and at same time lifting set. The chassis, which is mounted on the front portion of cabinet, should fall out. Proceed to service chassis.

NOTE #2 - This chassis is connected to one side of the power line. On AC operation an isolation transformer should be used to prevent shock hazard. To protect the signal generator, if no isolation transformer is available or if the radio is operated on DC, connect a 0.1 MFD capacitor between the high side of the signal generator and the radio.

The output of the signal generator should be no higher than necessary to obtain a usable output reading. Use a non-metallic type alignment screw-driver for adjustments. Connect signal generator ground to chassis.

FM IF ALIGNMENT USING FM SIGNAL GENERATOR AND OSCILLOSCOPE

FREQUENCY MODULATE THE IF SIGNAL WITH A 60 CYCLE SINE WAVE TO A TOTAL DEVIATION OF 450 KC. ADJUST THE OSCILLOSCOPE INTERNAL HORIZONTAL DEFLECTION VOLTAGE TO 120 CYCLES, AND SYNCHRONIZE IT WITH THE 60 CYCLE SINE WAVE.

	SIGNAL GENERATOR COUPLING	SIGNAL GEN. FREQ.	BAND SWITCH POS.	RADIO DIAL SETTING	CONNECT SCOPE	ADJUST	REMARKS
6.	TO PIN 8 (CATHODE) OF 12DT8 THROUGH A 50 MMF (REMOTE ANT. HANK)	10.7MC 145DKC TOTAL DEV.)	FM	POINT OF NON-INTERFERENCE	VERT. AMP TO POINT ◇ LOW SIDE TO CHASSIS.	S4, S3, S2, S1B, S1A.	DISCONNECT STABILIZER CAPACITOR 2MFD. ADJUST FOR CURVE OF MAXIMUM AMPLITUDE AND SYMMETRY SIMILAR TO FIG. 1.
7.	"	"	"	"	VERT. AMP TO POINT ◇ LOW SIDE TO CHASSIS.	S5	RECONNECT STABILIZING CAPACITOR 2MFD. ADJUST SO THAT 10.7MC OCCURS AT CENTER OF CROSSOVER LINES, SIMILAR TO FIG. 2. SLIGHTLY RETOUCH S-4 FOR MAXIMUM AMPLITUDE AND STRAIGHTNESS OF CROSSOVER LINES, PROCEED WITH STEP 8.

FM RF ALIGNMENT

	SIGNAL GENERATOR COUPLING	SIGNAL GEN. FREQ.	BAND SWITCH POS.	RADIO DIAL SETTING	CONNECT VTVM	ADJUST	REMARKS
8.	TO PIN 8 (CATHODE) OF 12DT8 THROUGH A 50 MMF (REMOTE ANT. HANK)	108MC	FM	108MC (SLUGS OUT)	DC PROBE TO POINT ◇ COMMON TO CHASSIS.	T1, T2	ADJUST FOR MAXIMUM DEFLECTION.
9.	"	88MC	"	88MC (SLUGS IN)	"	PADDER FLAPS	MOVE PADDER FLAPS CLOSER OR FURTHER FROM OSC. & RF COILS FOR MAX. DEFLECTION. REPEAT STEPS 8 & 9 FOR HIGHEST READING.

VOLUME R-19, MOST-OFTEN-NEEDED 1959 RADIO SERVICING INFORMATION

GRANCO PRODUCTS INC. MODEL 701 FM-AM RADIO

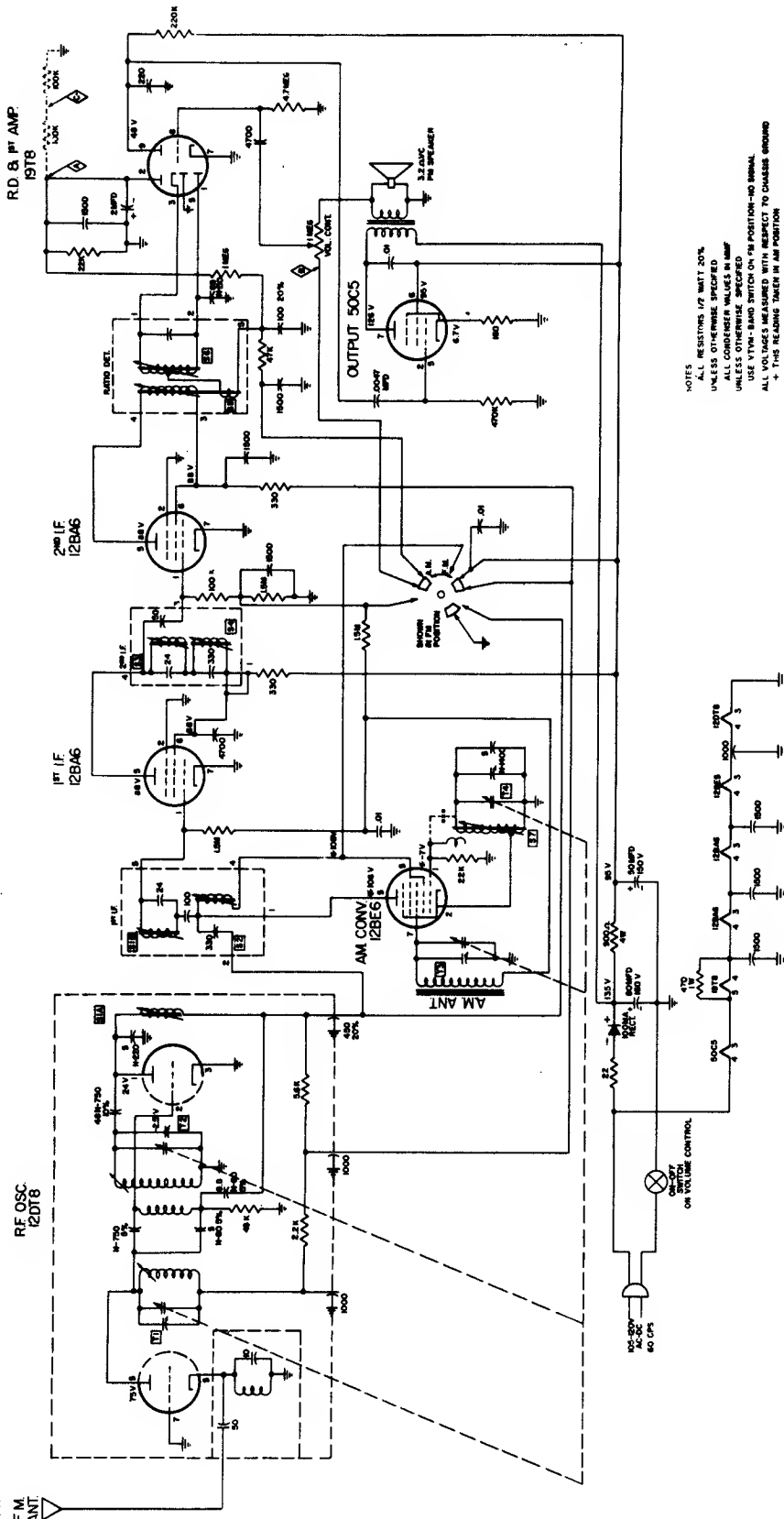

NOTES
 RESISTORS 1% NET 50%
 UNLESS OTHERWISE SPECIFIED
 ALL CONDENSER VALUES IN MUMF
 UNLESS OTHERWISE SPECIFIED
 USE VTM-BAND SWITCH ON FM POSITION-NO SIGNAL
 ALL VOLTAGES MEASURED WITH RESPECT TO CHASSIS GROUND
 + THIS READING TAKEN IN AM POSITION

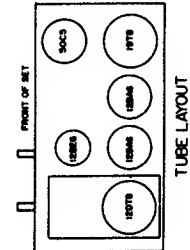

AM IF & RF ALIGNMENT

SIGNAL GENERATOR COUPLING	SIGNAL GEN. FREQ.	BAND SWITCH POS.	RADIO DIAL SETTING	CONNECT VTM	ADJUST	REMARKS
1. TO PIN 7 (GRID) OF 12BE6.	485KC (400 MOD.)	AM	TUNING GANG FULLY OPEN.	ACROSS VOICE COIL	S4, S2	ADJUST FOR MAXIMUM DEFLECTION.
2. LOOP (RADIATED)	610KC	"	TUNE TO 610KC SIGNAL	"	S7	ADJUST FOR MAXIMUM DEFLECTION. WHILE ROCKING TUNING GANG.
3. "	1650KC	"	TUNING GANG FULLY OPEN.	"	T3, T4	ADJUST FOR MAXIMUM DEFLECTION. REPEAT STEPS 1, 2, & 3.

For FM alignment information see instruction under Model 601, on preceding page, which can be applied to this set as well.

MONTGOMERY WARD & CO.

Model 1120A, -B

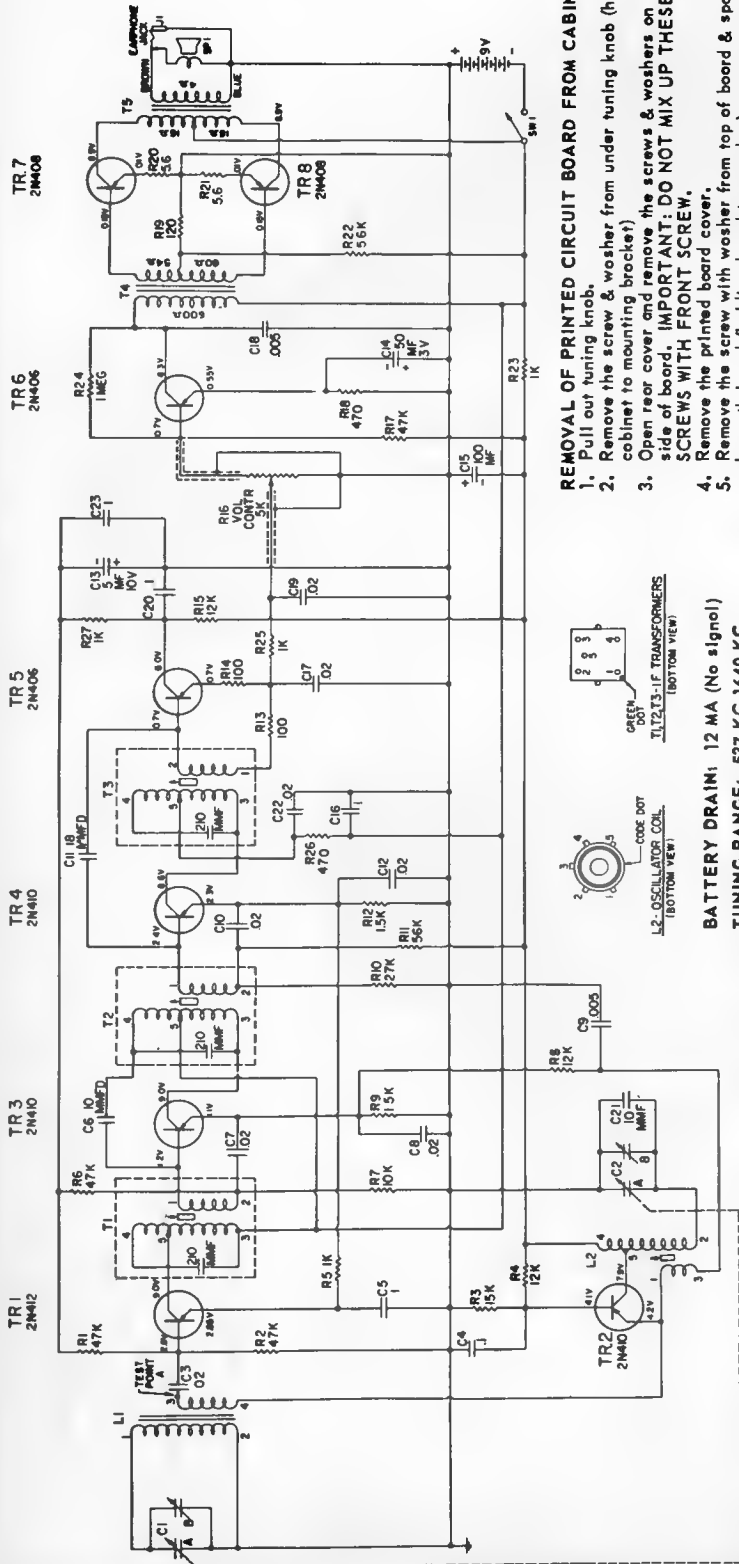

REMOVAL OF PRINTED CIRCUIT BOARD FROM CABINET

1. Pull out tuning knob.
2. Remove the screw & washer from under tuning knob (holding cabinet to mounting bracket).
3. Open rear cover and remove the screws & washers on each side of board. **IMPORTANT: DO NOT MIX UP THESE SCREWS WITH FRONT SCREW.**
4. Remove the printed board cover.
5. Remove the screw with washer from top of board & spacer beneath board (holding board to speaker).
6. Lift the printed board out of cabinet.
7. Unsolder speaker leads, if servicing requires removal of board from cabinet.

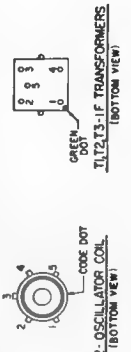

BATTERY DRAIN: 12 MA (No signal)
TUNING RANGE: 537 KC-1640 KC
I. F. STAGES: 455 KC

TOP VIEW OF BOARD SHOWING ALIGNMENT ADJUSTMENT LOCATIONS.

- 1) 1st I.F.
- 2) OSC. COIL
- 3) TRIM. C1B
- 4) TRIM. C2B
- 5) 2nd I.F.
- 6) 3rd I.F.



MOTOROLA

AUTO RADIO

MODEL
9AX

2N176
PWR AMP
MNS3 OR 2N652
DRIVER

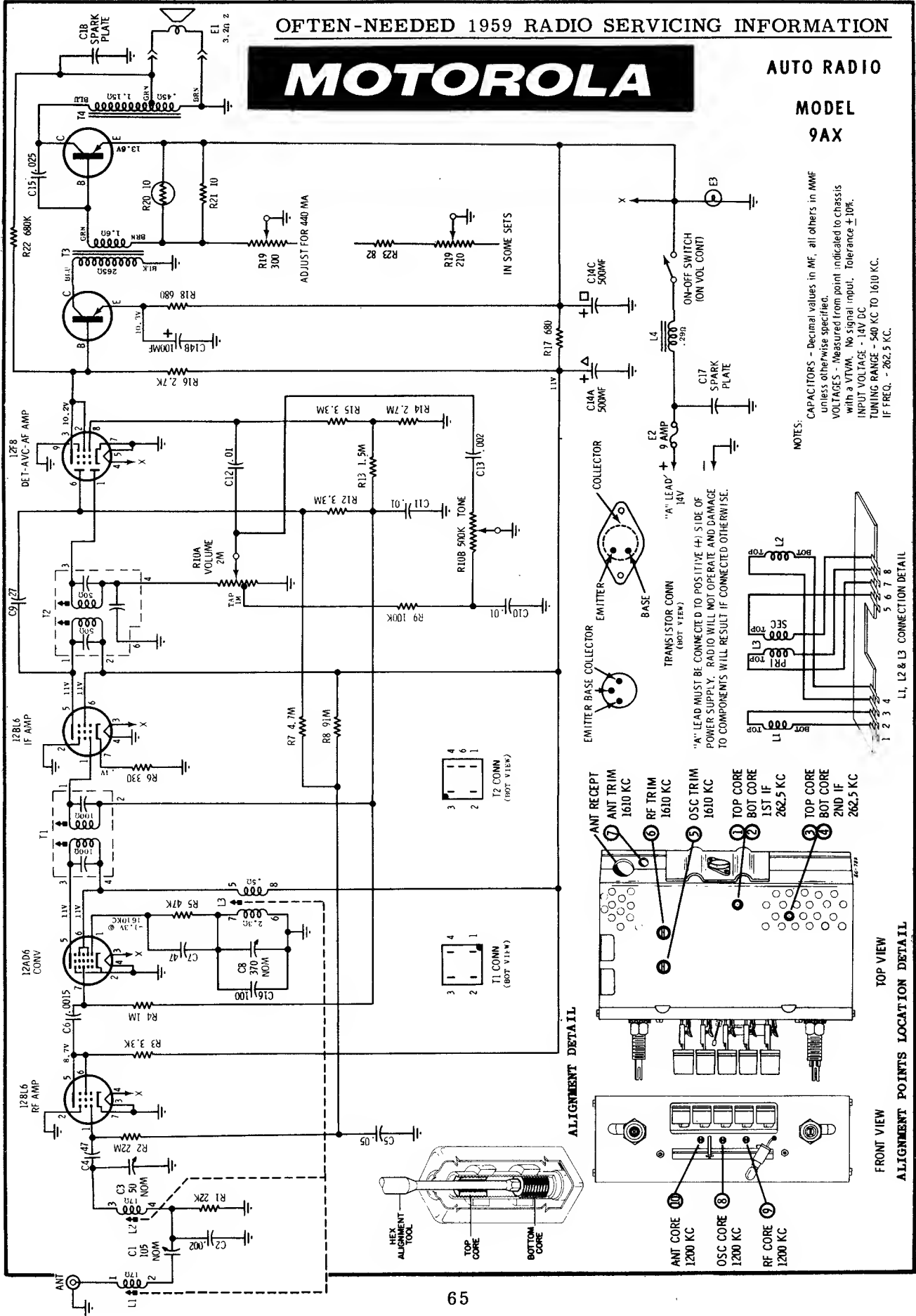

NOTES:
CAPACITORS - Decimal values in MF, all others in MMF unless otherwise specified.
VOLTAGES - Measured from point indicated to chassis with a VTVM. No signal input. Tolerance $\pm 10\%$.
INPUT VOLTAGE - 14V DC
TUNING RANGE - 540 KC TO 1610 KC.
IF FREQ. - 262.5 KC.

"A" LEAD MUST BE CONNECTED TO POSITIVE (+) SIDE OF POWER SUPPLY. RADIO WILL NOT OPERATE AND DAMAGE TO COMPONENTS WILL RESULT IF CONNECTED OTHERWISE.

MOTOROLA

Model CTA9X

Models BKA9X, OEA9X, PCA9X, are electrically very similar to CTA9X covered on this page.

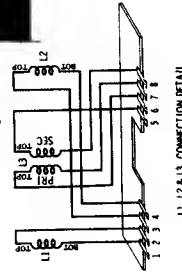

NOTES:
CAPACITORS - Decimal values in μ F, all others in MMF unless otherwise specified.
VOLTAGES - Measured from point indicated to chassis unless otherwise noted.
CURRENTS - Measured from input, tolerance $\pm 10\%$.
TUNING RANGE - 540 KC to 1610 KC.
IF FREQ. - 262.5 KC.

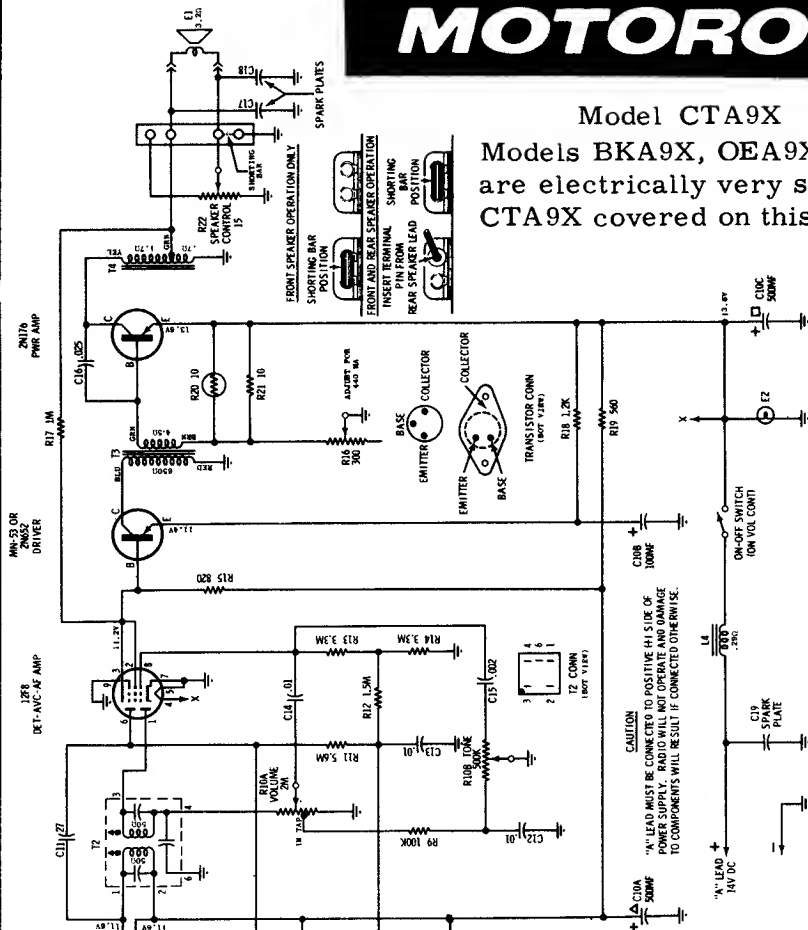

POWER TRANSISTOR CURRENT ADJUSTMENT - After a power transistor has been replaced, the collector current should be checked and adjusted for proper operation.

- Connect a 0-3 amp DC ammeter in series with the "A" lead.
- Remove output transistor from its socket.
- Turn radio on and read ammeter with 12.6 volts input to "A" lead (approximately 800 ma). **NOTE READING.**
- Turn radio off and replace transistor
- Turn radio on and adjust R-16 for a 360 ma increase over reading noted in step c with 12.6 volts input to "A" lead.

NOTE: Two values of radio input voltage are given as a convenience to service personnel in order to accommodate different power sources. The current value of 440 ma stated on the schematic is for 14 volts DC input to receiver "A" lead.

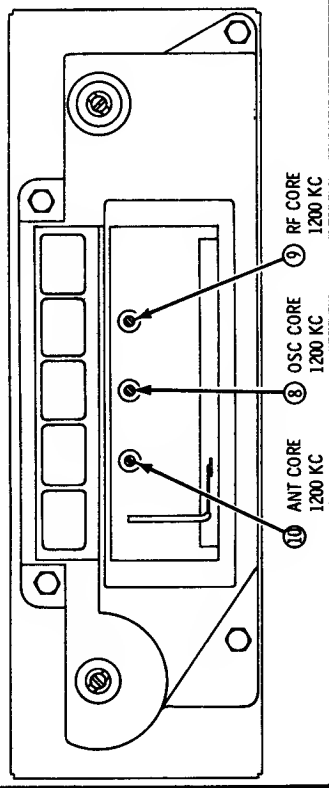
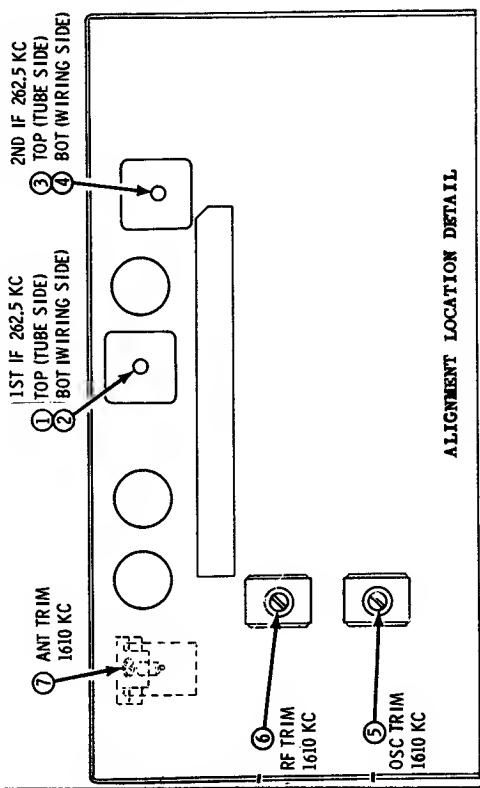

MOTOROLA

MODEL
CTM9X

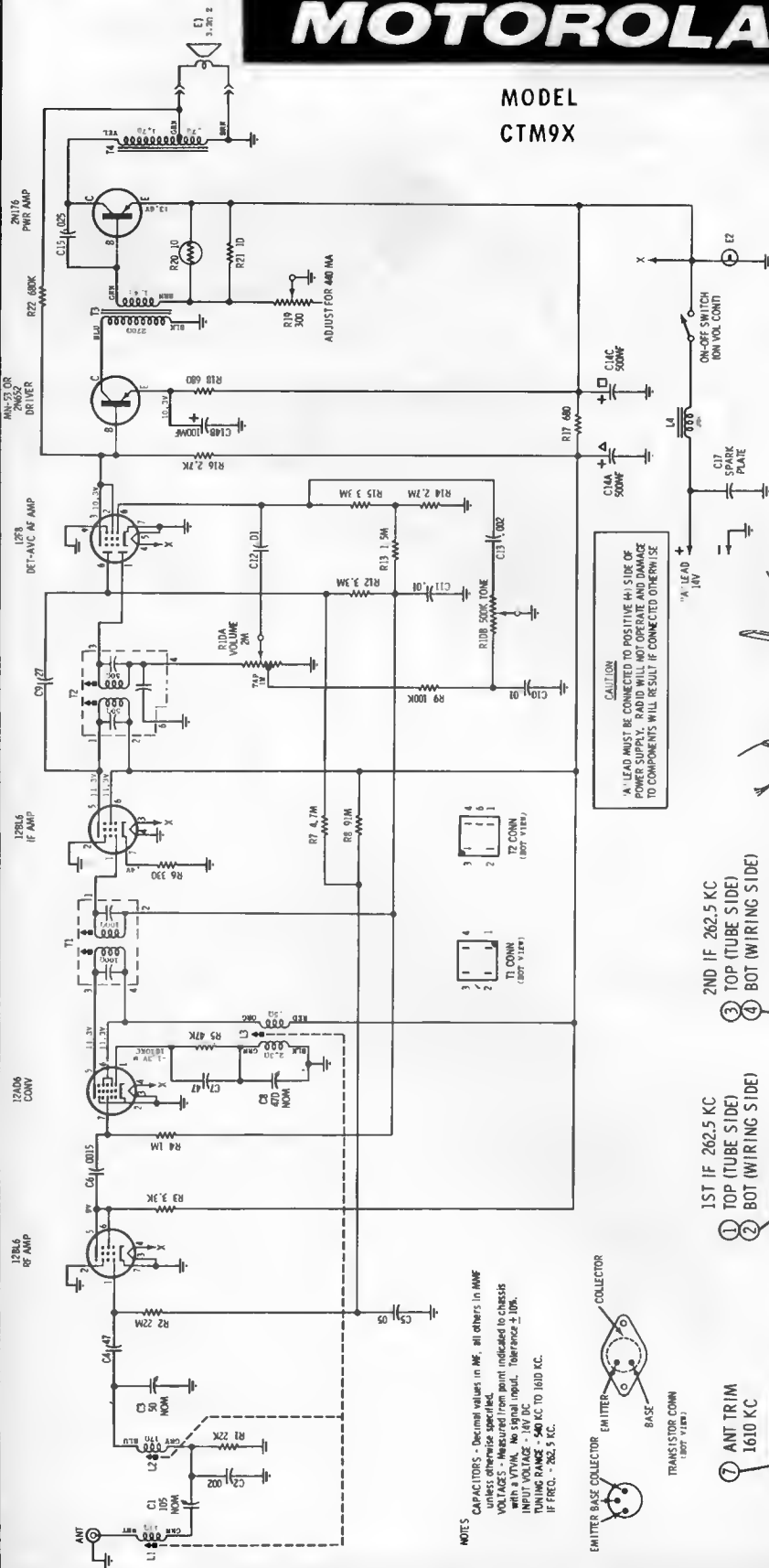

NOTES
CAPACITORS - Decimal values in MF, all others in MWF unless otherwise specified.
VOLTAGES - Measured from point indicated to chassis with a VTVM. No signal input. Tolerance $\pm 10\%$.
INPUT VOLTAGE - 180 DC.
TUNING RANGE - 540 KC TO 1610 KC.
IF FREQ. - 455.5 KC.

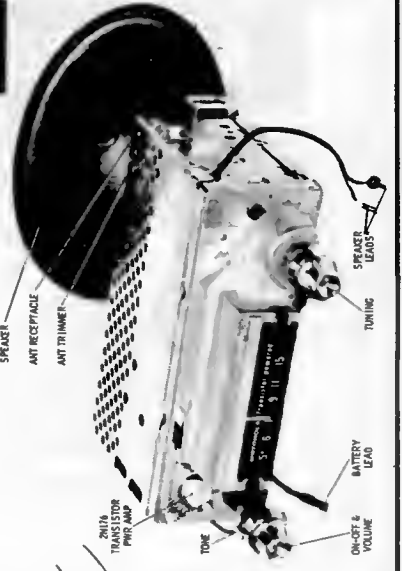
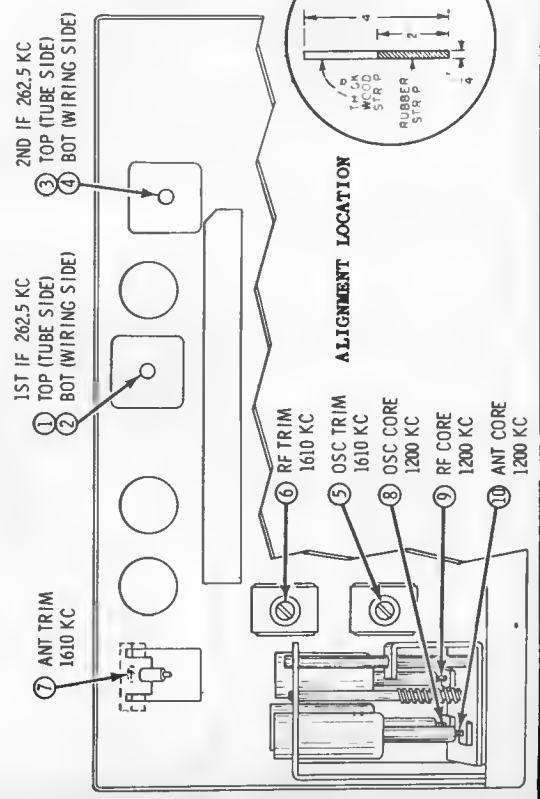

CORE ALIGNMENT TOOL DETAIL

MOTOROLA

MODEL
AMERICAN MOTORS 8990582
MOTOROLA 93MR

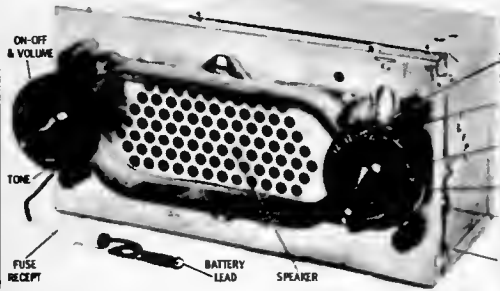
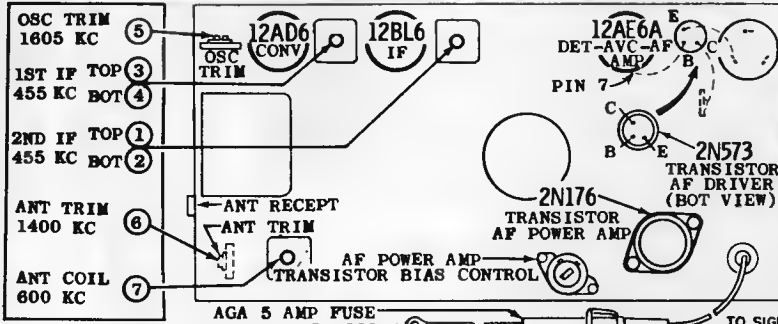

ALIGNMENT ADJUSTMENTS LOCATION

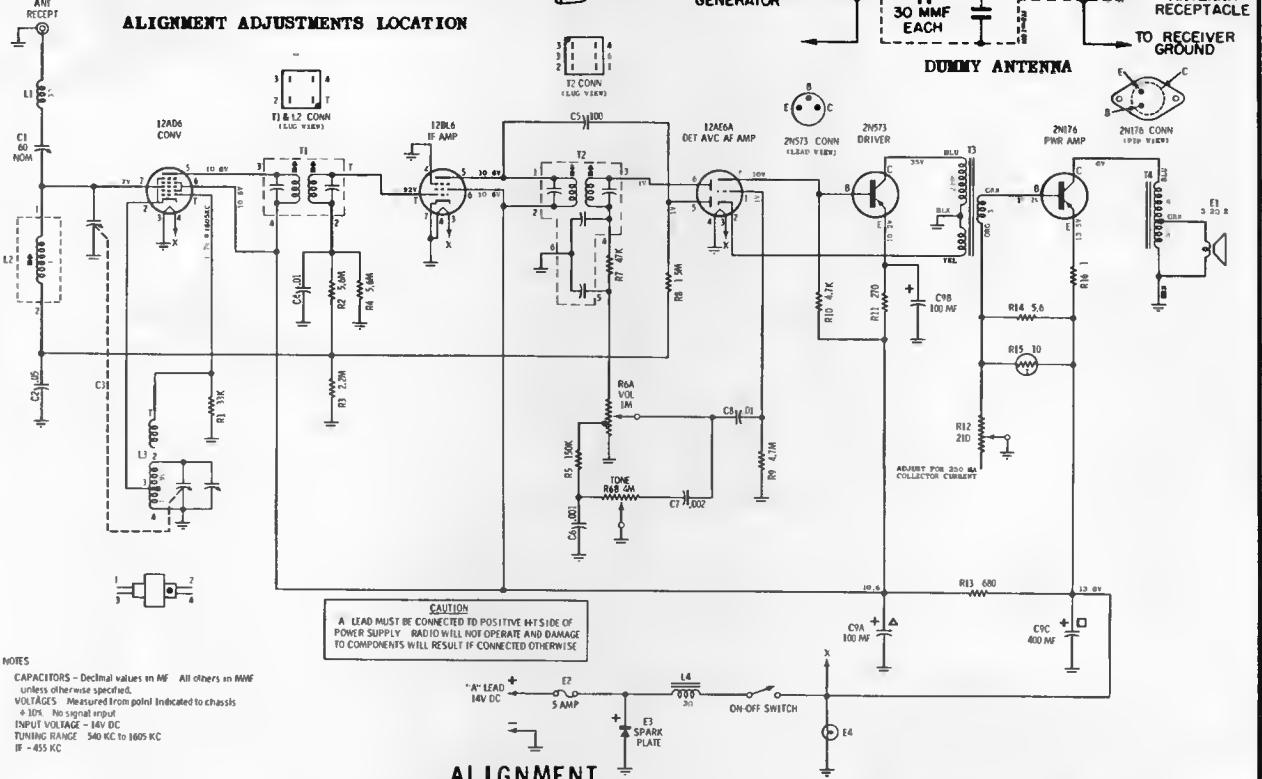

ALIGNMENT

Connect an output meter across the speaker voice coil. Set tone control to high and volume to maximum. Attenuate signal generator output to maintain 1.3 volts on output meter to prevent overloading the receiver.

STEP	GENERATOR CONNECTION	GENERATOR FREQUENCY (400 cycle mod)	GANG SETTING	ADJUST	REMARKS
IF ALIGNMENT					
1.	Ant recept through .1 mf & chassis	455 Kc	Fully open	1, 2, 3 & 4	Peak for maximum.
RF ALIGNMENT					
2.	Ant recept through dummy antenna	1605 Kc	Fully open	5	Peak for maximum.
3.	"	1400 Kc	Tune for max	6	Peak for maximum.
4.	"	600 Kc	Tune for max	7	Peak for maximum while rocking gang.
5.	Repeat steps 3 & 4 until no further increase. The last adjustment should be the trimmer (6).				
ANTENNA TRIMMER					
6.	-	-	Tune to a weak station around 1400 Kc	6	With radio installed in car and antenna fully extended, peak antenna trimmer for max.

MOST-OFTEN-NEEDED 1959 RADIO SERVICING INFORMATION

MOTOROLA

MODEL
AMERICAN MOTORS 8990576
MOTOROLA 94MA

VC
-125V @ 400 CYCLES AT GRID OF 12A6GA
FOR ONE WATT OUTPUT
6
40X
262.5 KC TO 400 CYCLES
70X
1000 KC TO 262.5 KC
3.3X
1000 KC
6.3X
1000 KC

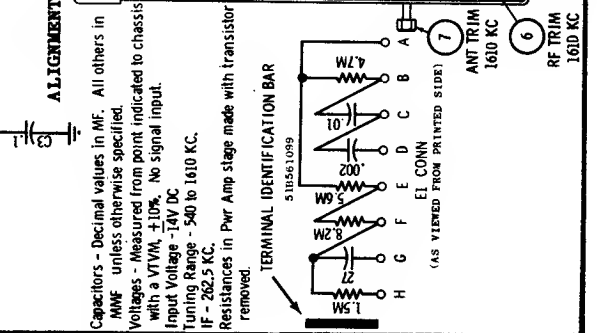
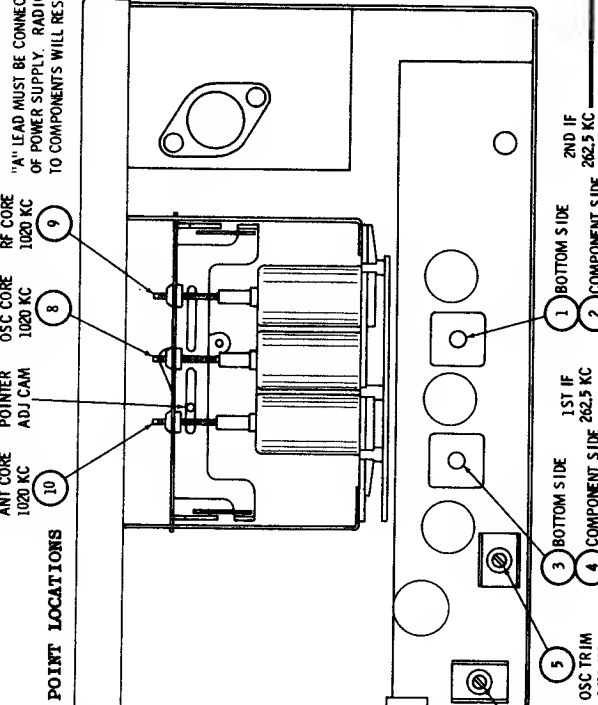
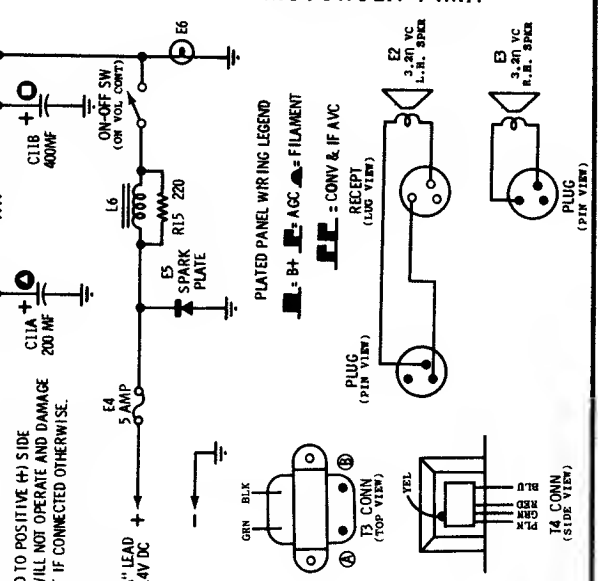
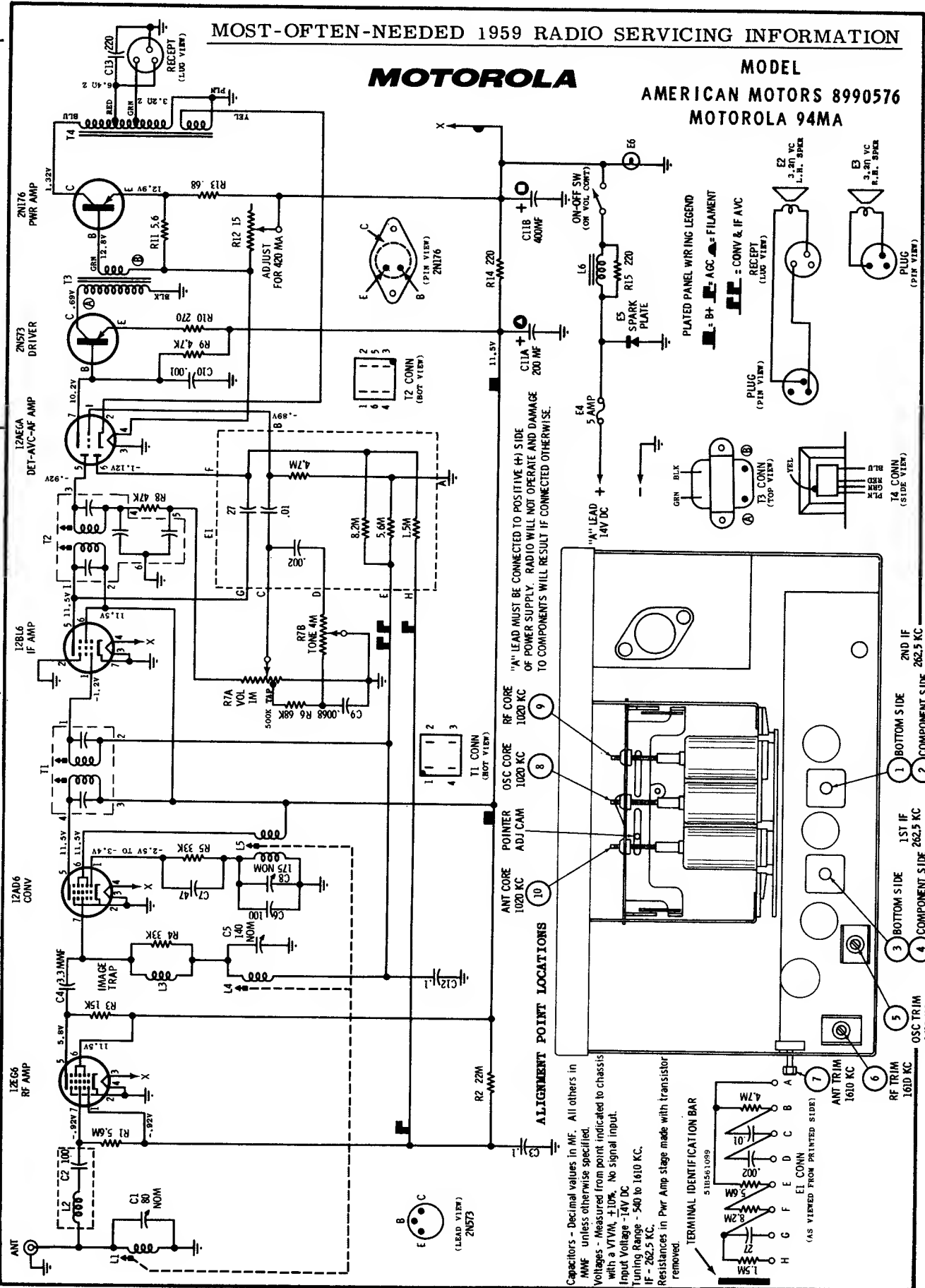

"A" LEAD MUST BE CONNECTED TO POSITIVE (+) SIDE OF POWER SUPPLY. RADIO WILL NOT OPERATE AND DAMAGE TO COMPONENTS WILL RESULT IF CONNECTED OTHERWISE.

Capacitors - Decimal values in MF. All others in MMF unless otherwise specified.
 Voltages - Measured from point indicated to chassis with a VTVM, $\pm 10\%$. No signal input.
 Input Voltage - 14V DC
 Tuning Range - 540 to 1610 KC.
 IF - 262.5 KC.
 Resistances in Pwr Amp stage made with transistor removed.

MOTOROLA

MODELS
 MOTOROLA 94MF, 94MFM
 FORD B9FA-18806-C, B9FA-18805-E

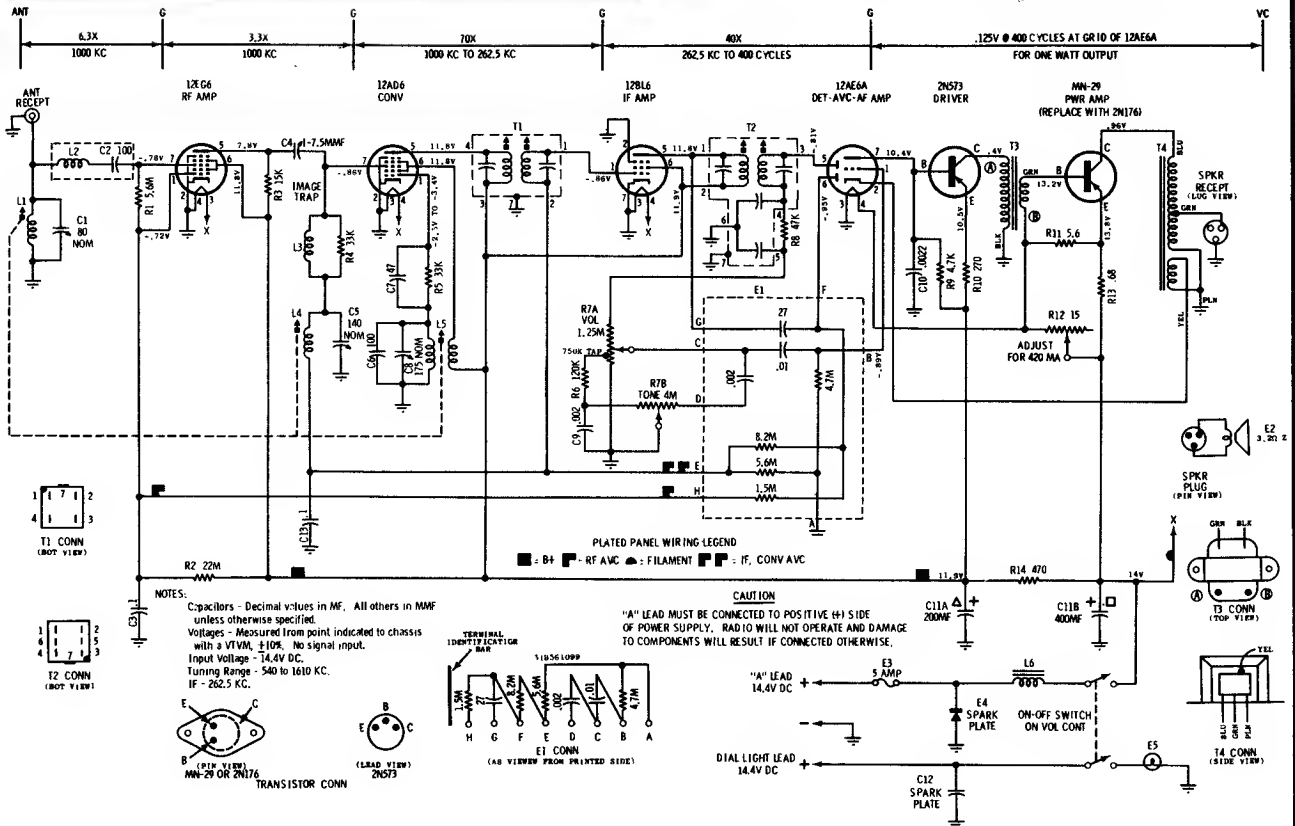

ALIGNMENT POINT LOCATION DETAIL

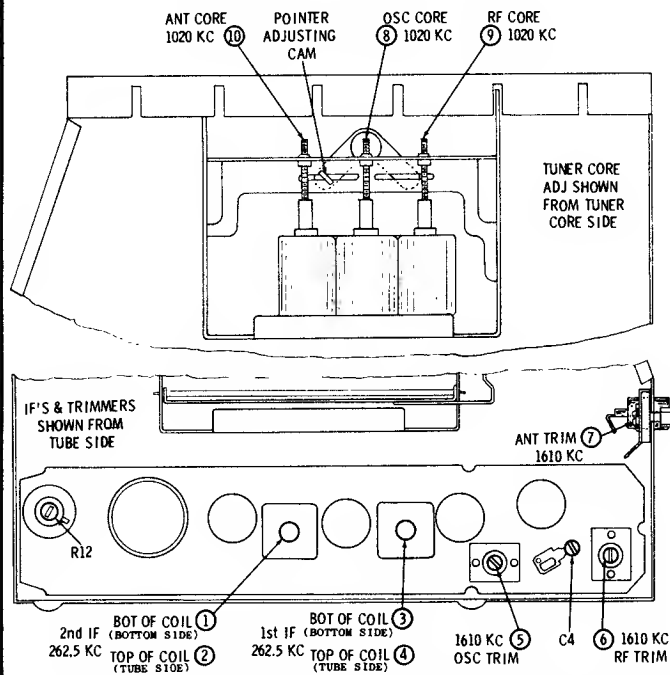

PLATED CIRCUIT COMPONENT REPLACEMENT

Most of the components can be removed from the panel with the aid of a soldering iron. When using a soldering pot, it may be difficult to dip some of the components close to the edge of the panel because of interference from the radio housing. To use a soldering pot on these components, it will be necessary to partially drop the panel from the housing. to do this proceed as follows:

- Remove two screws which hold radio housing to front plate (on volume control side of housing).
- Unsolder connecting lead from antenna spark choke at trimmer side.
- Unsolder plated panel support bracket from housing and panel, bend ears straight, and carefully remove from plated panel.
- Carefully remove plated panel from housing and drop below edge of housing.
- Replace screws removed from housing in step "a." so panel and housing will be more solid during soldering operation.

PLATED CHASSIS REMOVAL - If necessary to remove the plated panel completely from radio housing, proceed as follows:

- Remove two screws which hold radio housing to front plate (on volume control side of housing).
- Unsolder connecting leads to free panel. Where possible, avoid unsoldering leads at plated panel.
- Unsolder plated panel support bracket from housing and panel, bend ears straight, and carefully remove bracket from panel and housing.
- Plated panel will now be free for careful removal from housing.

MOTOROLA

**MODEL
MOTOROLA 95MF
FORD B9FA-18806-B**

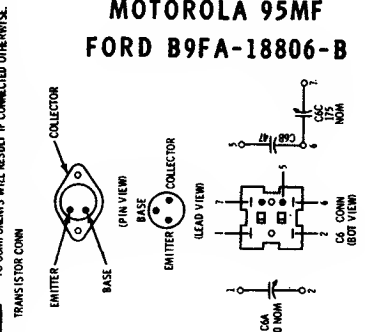
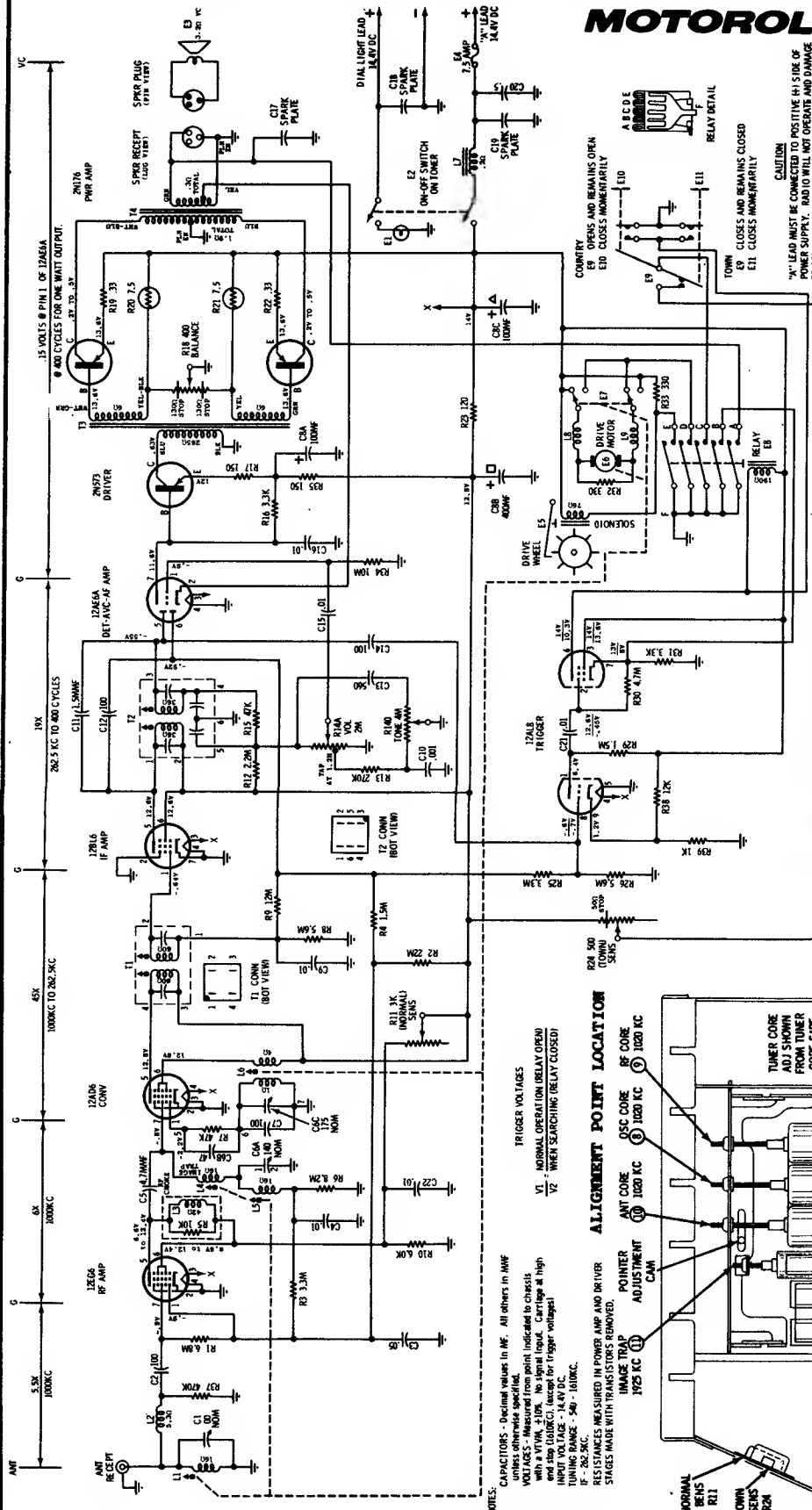

DRIVER TRANSISTOR REPLACEMENT - When replacing a driver transistor, the heat must be carried away from the transistor to prevent heat damage while soldering. This can be accomplished by grasping the transistor leads (between the transistor and soldering lug) with a pair of long-nose pliers.

TRANSISTOR CURRENT ADJUSTMENT - After replacing transistor and before connecting radio to power supply, set the transistor balance control (R-18) to the mid-position to prevent excessive current from damaging the transistors. Allow about 15 minutes warm-up time before proceeding with the following:

- Connect a VTVM from collector to collector. Be sure VTVM is accurately zeroed and set to a low voltage scale. **NOTE:** If VTVM has a center zero scale, use this scale.
- Adjust R-18 for zero DC reading on VTVM.

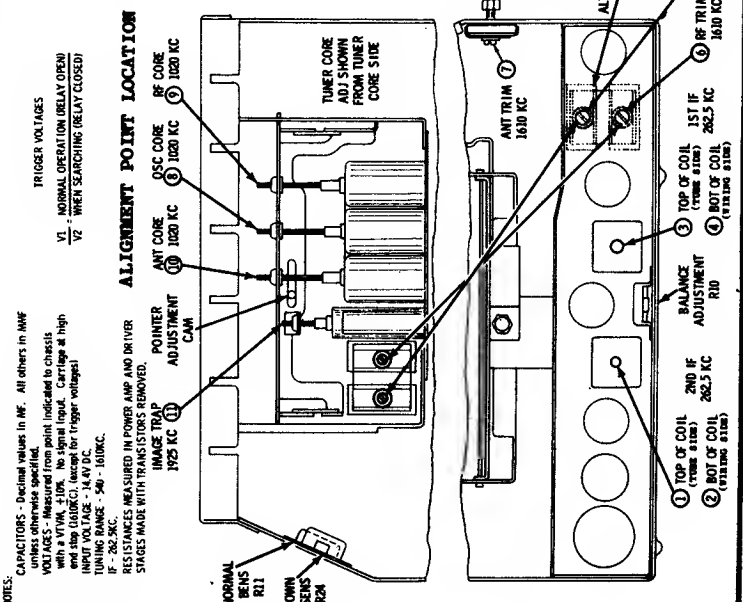

MOTOROLA

Models 300X and 301X

These are 12-volt sets designed for universal underdash installation. Model 300X, circuit on this page, is for use in cars with a negative ground electrical system. Model 301X, diagram on next page adjacent at right, is for cars with positive ground electrical system. Other material applies to both models.

MODEL 300X SCHEMATIC DIAGRAM

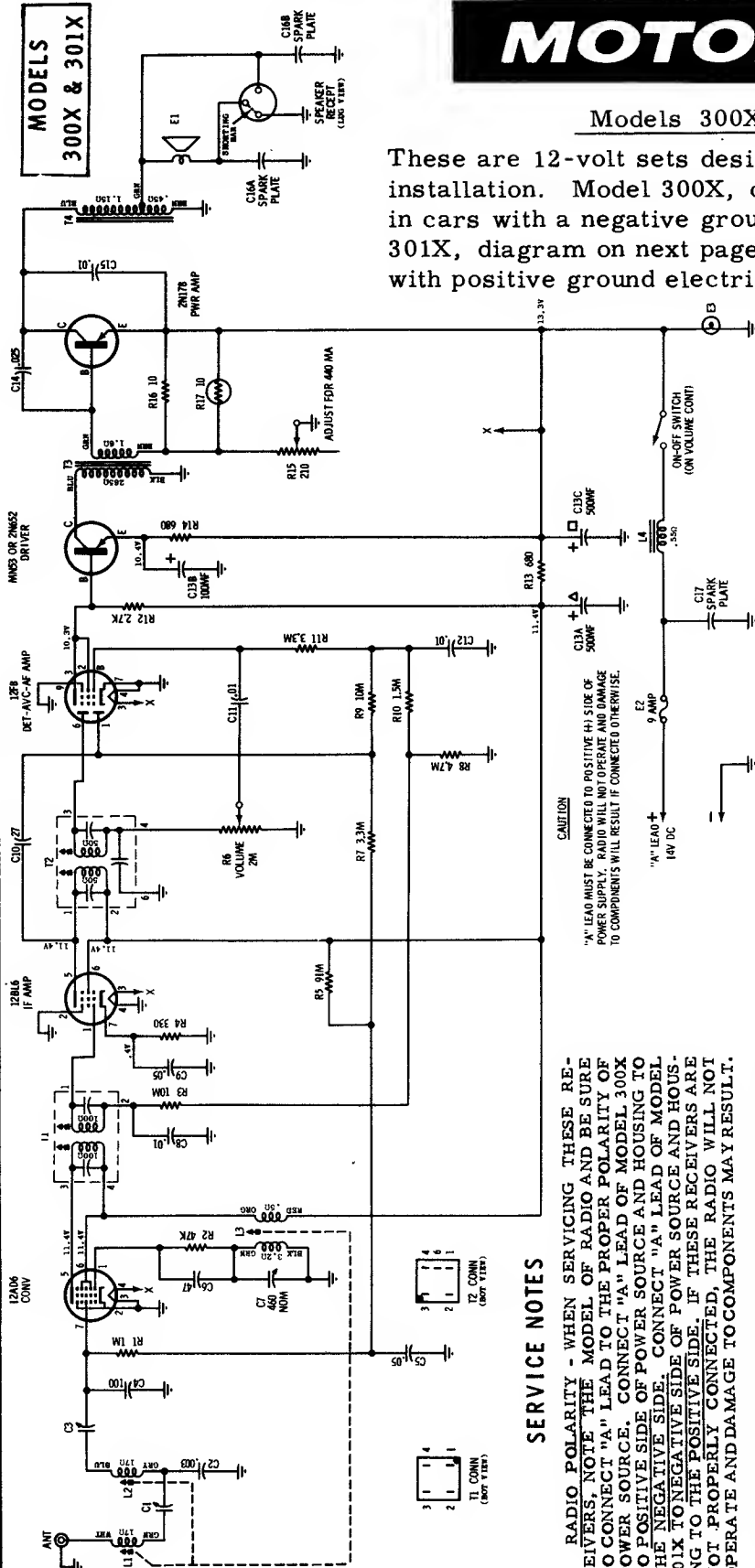

NOTE:
CAPACITORS - Decimal values in MF, all others in MWF unless otherwise specified.
VOLTAGES - Measured from point indicated to chassis with a VTVM, No signal input. Tolerance $\pm 10\%$.
INPUT VOLTAGE - 14V DC.
TUNING RANGE - 540 KC TO 1610 KC.
IF FREQ. - 262.5 KC.

NOTE: Two values of radio input voltage are given as a convenience to service personnel in order to accommodate different power sources. The current value of 440 ma stated on the schematic is for 14 volts DC input to receiver "A" lead.

POWER TRANSISTOR INSULATOR - When replacing a power transistor or power transistor insulator, be sure to coat both sides of insulator with DC-4 Grease (Motorola Part No. 11M490487) to insure proper heat dissipation.

TRANSISTOR CHECK - The transistors used in this receiver can be expected to give unusually long trouble-free life. However, the following transistor checks are provided to facilitate servicing:

Substituting a known good transistor for a suspected one is the simplest and most positive way of checking transistors. When a transistor is not available for substitution, make a resistance check of the stage. If the values are within the tolerance rating, the bias network can be eliminated as a source of defect and the transistor safely suspected. Bias network defects can be located by resistance checks.

SERVICE NOTES

RADIO POLARITY - WHEN SERVICING THESE RECEIVERS, NOTE THE MODEL OF RADIO AND BE SURE TO CONNECT "A" LEAD TO THE PROPER POLARITY OF POWER SOURCE. CONNECT "A" LEAD OF MODEL 300X TO POSITIVE SIDE OF POWER SOURCE AND HOUSING TO THE NEGATIVE SIDE. CONNECT "A" LEAD OF MODEL 301X TO NEGATIVE SIDE OF POWER SOURCE AND HOUSING TO THE POSITIVE SIDE. IF THESE RECEIVERS ARE NOT PROPERLY CONNECTED, THE RADIO WILL NOT OPERATE AND DAMAGE TO COMPONENTS MAY RESULT.

POWER SUPPLY REQUIREMENTS - It is preferable to use a storage battery (without a battery charger) in place of a battery eliminator when servicing this receiver, because the average eliminator has an extremely high AC ripple content which may damage the transistor and other low voltage components.

POWER TRANSISTOR CURRENT ADJUSTMENT - After a power transistor has been replaced, the collector current should be checked and adjusted for proper operation.

- a. Connect a 0-3 amp DC ammeter in series with the "A" lead.
- b. Remove output transistor from its socket.
- c. Turn radio on and read ammeter with 12.6 volts input to "A" lead (approximately 800 ma). **NOTE READING.**
- d. Turn radio off and replace transistor.
- e. Turn radio on and adjust R-15 for a 360 ma increase over reading noted in step c with 12.6 volts input to "A" lead.

MOTOROLA Models 300X and 301X, Continued

This page has the circuit of Model 301X, and other service material that is applicable to both 300X and 301X. See also the material on previous page, at left.

MODEL 301X SCHEMATIC DIAGRAM

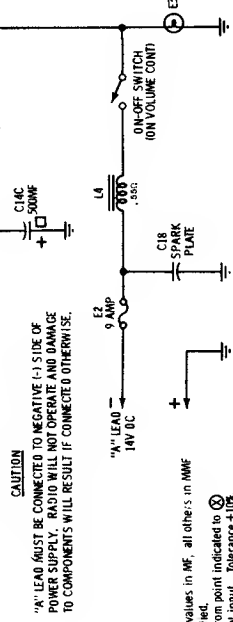
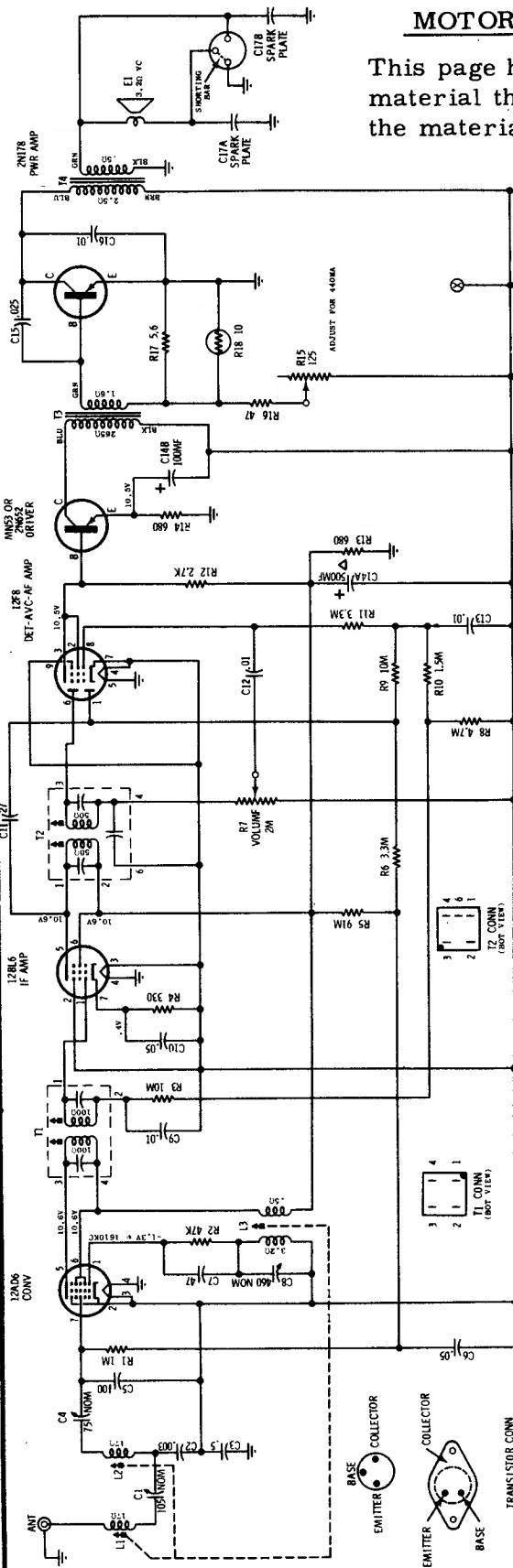

CAUTION
"A" LEAD MUST BE CONNECTED TO NEGATIVE (-) SIDE OF POWER SUPPLY. RADIO WILL NOT OPERATE AND DAMAGE TO COMPONENTS WILL RESULT IF CONNECTED OTHERWISE.

NOTES
CAPACITORS - Decimal values in MF, all others in MMF, unless otherwise specified.
VOLTAGES - Measured from point indicated to ⊕ with a VTVM. No signal input. Tolerance ±10%.
INPUT VOLTAGE - 14V DC.
TUNING RANGE - 540 KC to 1610 KC.
IF FREQ. - 262.5 KC.

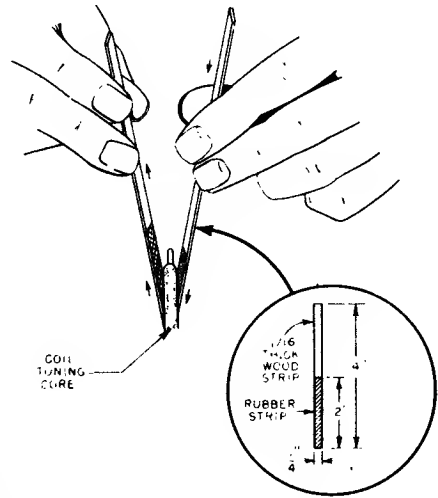

CORE ALIGNMENT TOOL DETAIL

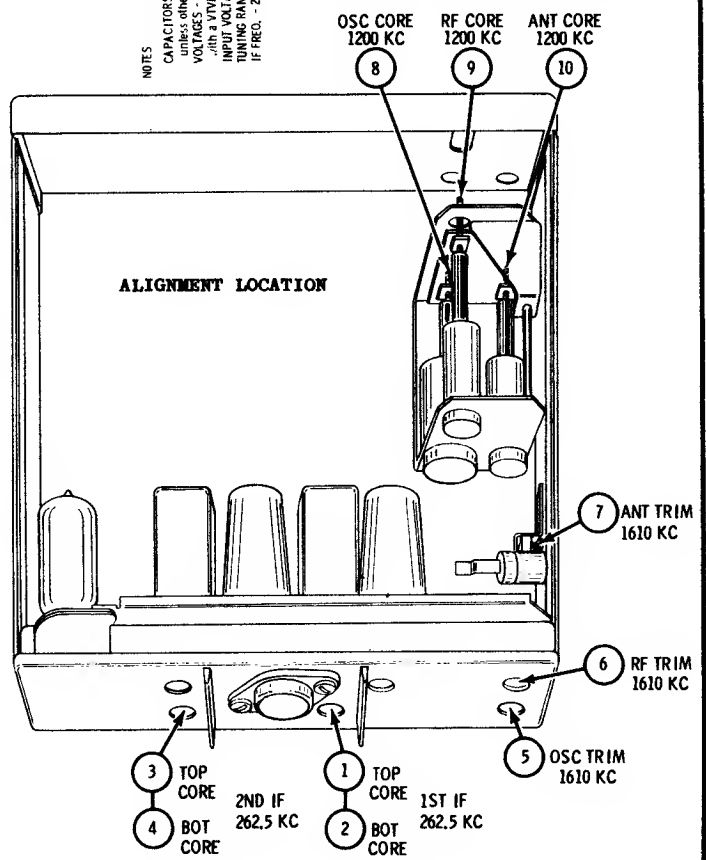

MOTOROLA

MODEL
406

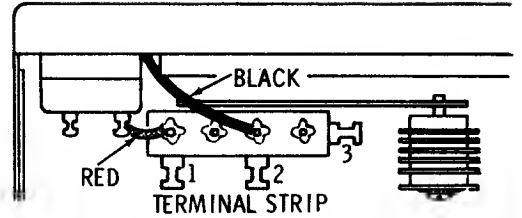

RADIO WIRING FOR CARS WITH A NEGATIVE GROUND ELECTRICAL SYSTEM - RED LEAD MUST BE SOLDERED TO TERMINAL NO. 1; BLACK LEAD TO TERMINAL NO. 2.

RADIO POLARITY - BEFORE CONNECTING RADIO TO A 6 VOLT POWER SOURCE, REMOVE BOTTOM COVER AND CHECK POLARITY WIRING AGAINST DETAIL. THEN CONNECT RADIO TO POWER SOURCE PER DETAIL. IF THIS RECEIVER IS NOT PROPERLY CONNECTED, IT WILL NOT OPERATE AND DAMAGE TO COMPONENTS MAY RESULT.

OUTPUT TRANSISTOR CURRENT ADJUSTMENT - After an output transistor has been replaced, the collector current should be checked and adjusted for proper operation.

- Connect a 3 amp DC ammeter in series with the "A" lead.
- Remove output transistor from its socket.
- Turn radio on and read ammeter with 6.3 volts input to "A" lead (approximately 2.0 amp). **NOTE READING.**
- Turn radio off and replace transistor
- Turn radio on and adjust R-14 for a 600 ma increase over reading noted in step c with 6.3 volts input to "A" lead.

NOTE: Two values of radio input voltage are given as a convenience to service personnel in order to accommodate different power sources. The current value of 720 ma stated on the schematic is for 7 volts DC input to receiver "A" lead.

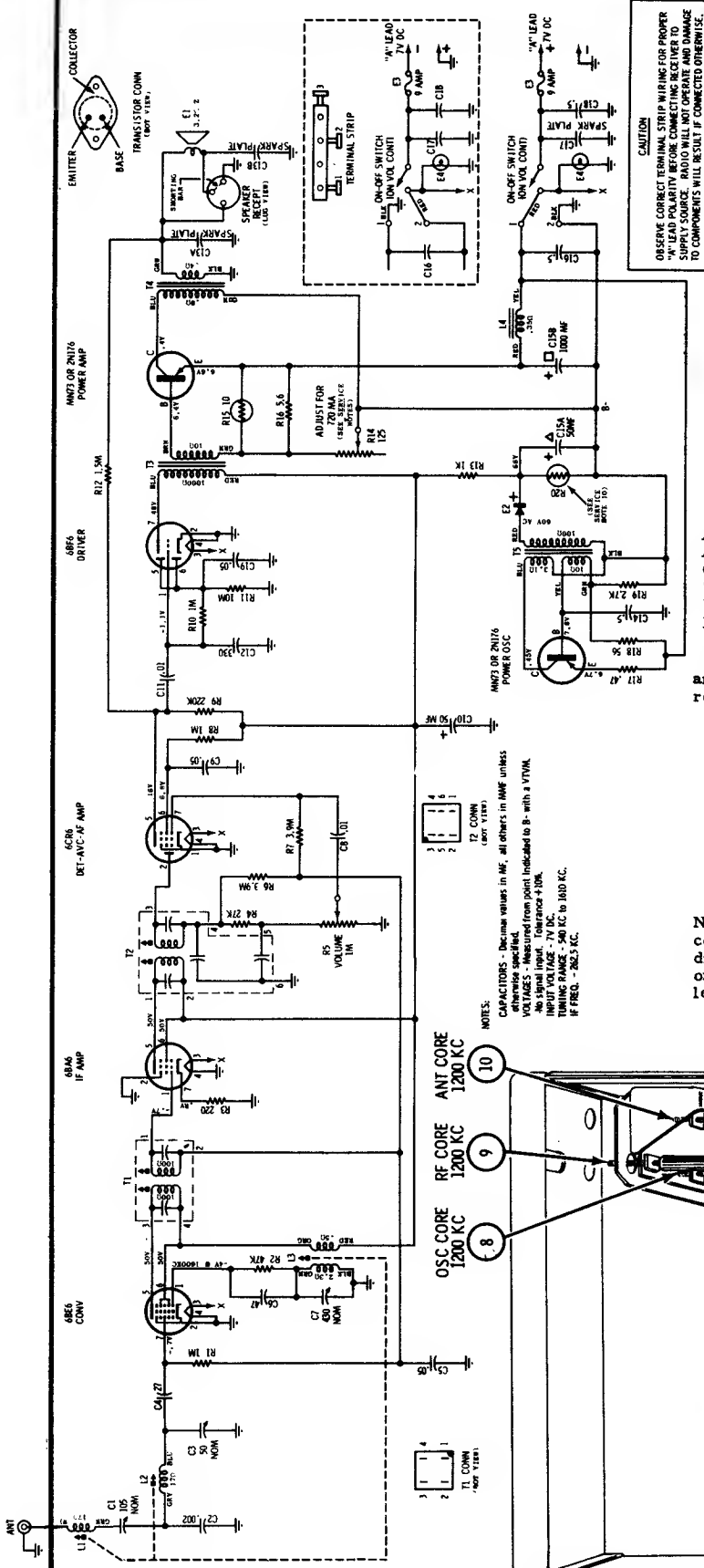

CAUTION
OBSERVE CORRECT TERMINAL STRIP WIRING FOR PROPER "A" LEAD POLARITY. BEFORE CONNECTING RADIO TO POWER SUPPLY SOURCE. RADIO WILL NOT OPERATE AND DAMAGE TO COMPONENTS WILL RESULT IF CONNECTED OTHERWISE.

NOTES:
CAPACITORS - Resistor values in μ F, all others in MMF unless indicated.
VOLTAGES - Measured from point indicated to B - with a VTVM.
No signal input. Tolerance $\pm 10\%$.
INPUT VOLTAGE - 7V DC.
TUNING RANGE - 540 KC to 1610 KC.
IF FREQ. - 262.5 KC.

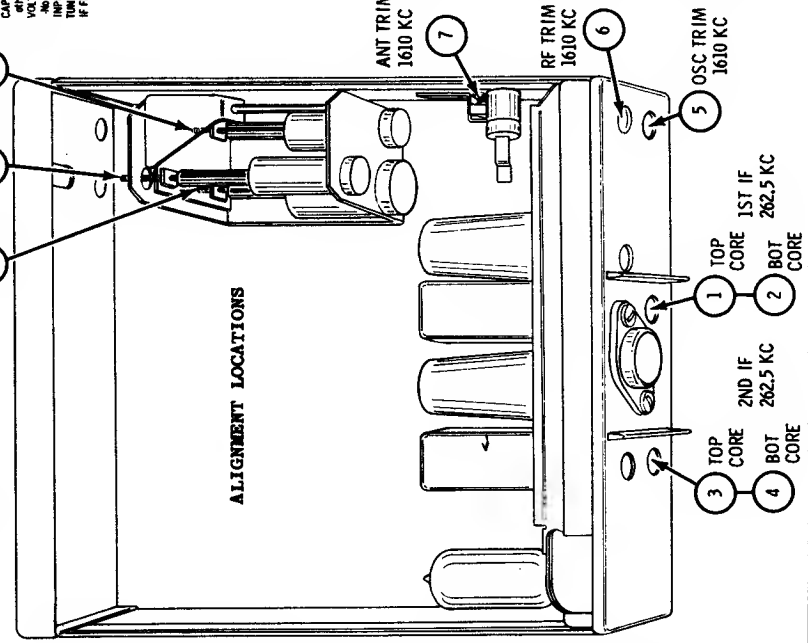

MOTOROLA

MODEL
GV-701

TRANSISTOR CURRENT ADJUSTMENT - After replacing a transistor, the collector current must be adjusted to insure proper operation of the output stage. Adjustment of the collector current must be made within one minute after the receiver has been turned on - before it has time to warm up. If the receiver is warm from operation, it will have to be cooled before adjusting the collector current.

A. Set R-21 to maximum resistance position (fully counter-clockwise when viewed from the wiring side) so that the new transistor does not draw excessive collector current and "run away".

B. Unsolder output transformer (T-4) black lead and grounded speaker lead from chassis; connect the two leads together. Be sure speaker is connected while making adjustment; volume control must be set to minimum. Connect the positive side of a 0 - 1.0 amp DC ammeter to the two leads just removed and the negative side to chassis. The

meter used must have an internal resistance of .05 ohms or less; if higher, meter will act as a current limiter and cause an incorrect adjustment.

C. Adjust R-21, within one minute, after turning on a cold receiver for a total collector current reading of 160 ma with 12.6 volts input to receiver's "A" lead. Resolder two leads to chassis after adjustment.

NOTE: Two values of receiver input voltage are given as a convenience to service personnel to accommodate different power sources. The schematic total collector current value of 200 ma is stated with 14 volts DC input to receiver's "A" lead.

POWER TRANSISTOR INSULATOR - When replacing a power transistor or power transistor insulator, be sure to coat both sides of insulator with DC-4 grease (Motorola Part No. 11M490487) to insure proper heat dissipation.

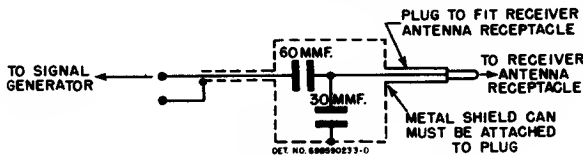

DUMMY ANTENNA DETAIL

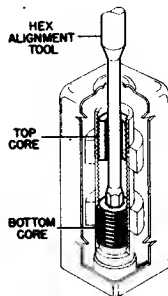

IF ALIGNMENT DETAIL

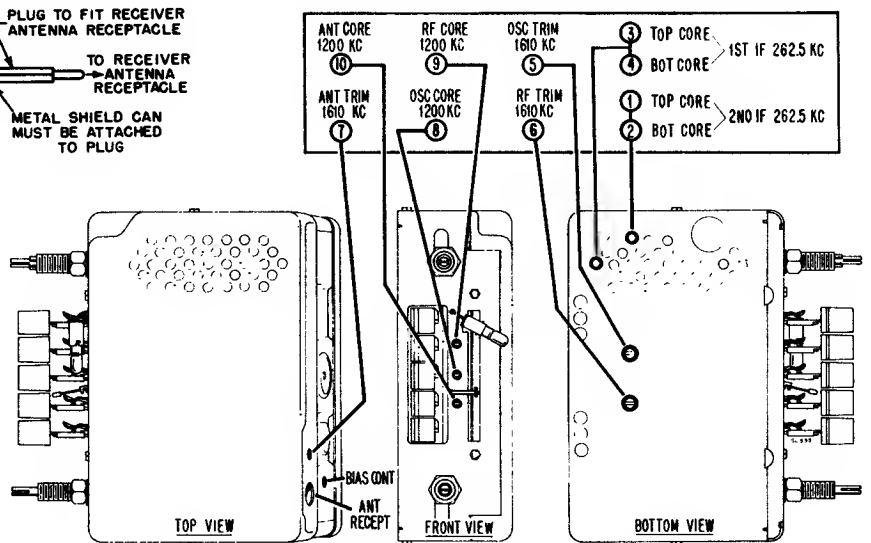

ALIGNMENT POINT LOCATIONS DETAIL

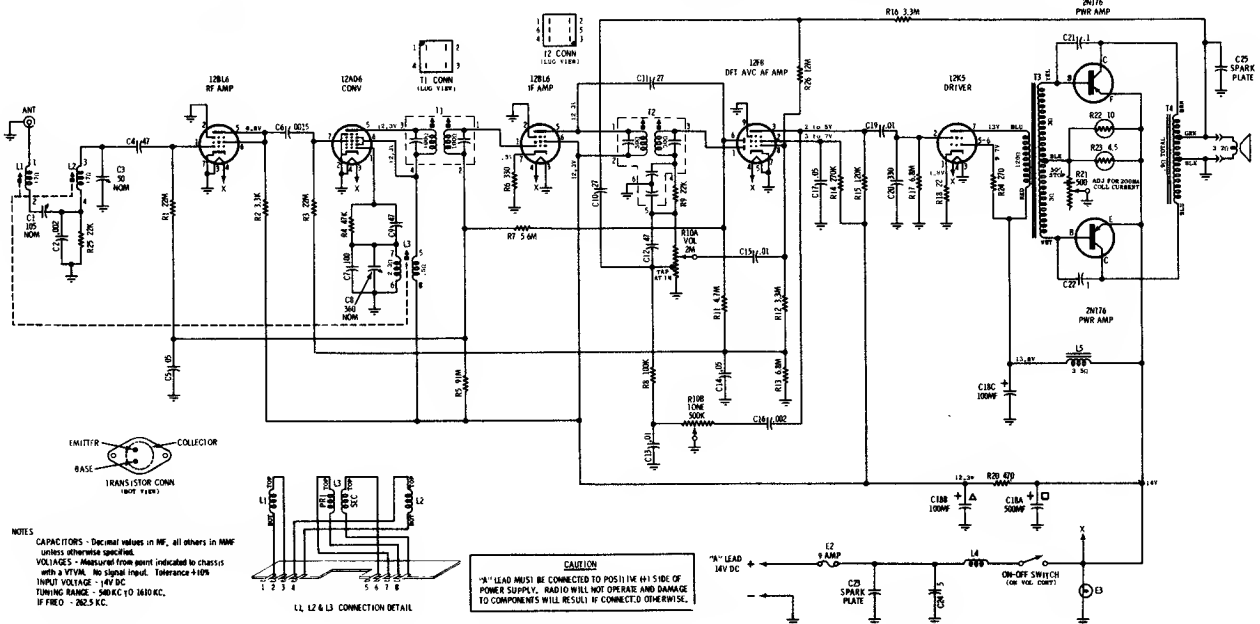

NOTES
CAPACITORS - Decimal values in MF, all others in MUF unless otherwise specified.
VOLTAGES - Measured from point indicated to chassis with a VTVM. No signal input. Tolerance +10%
INPUT VOLTAGE - 14V DC
TUNING RANGE - 300 KC TO 1610 KC.
IF FREQ - 262.5 KC.

CAUTION
"A" LEAD MUST BE CONNECTED TO POSITIVE (+) SIDE OF POWER SUPPLY. RADIO WILL NOT OPERATE AND DAMAGE TO COMPONENTS WILL RESULT IF CONNECTED OTHERWISE.

MOTOROLA

Auto Radio Model GV-800
(Continued on the next page at right)

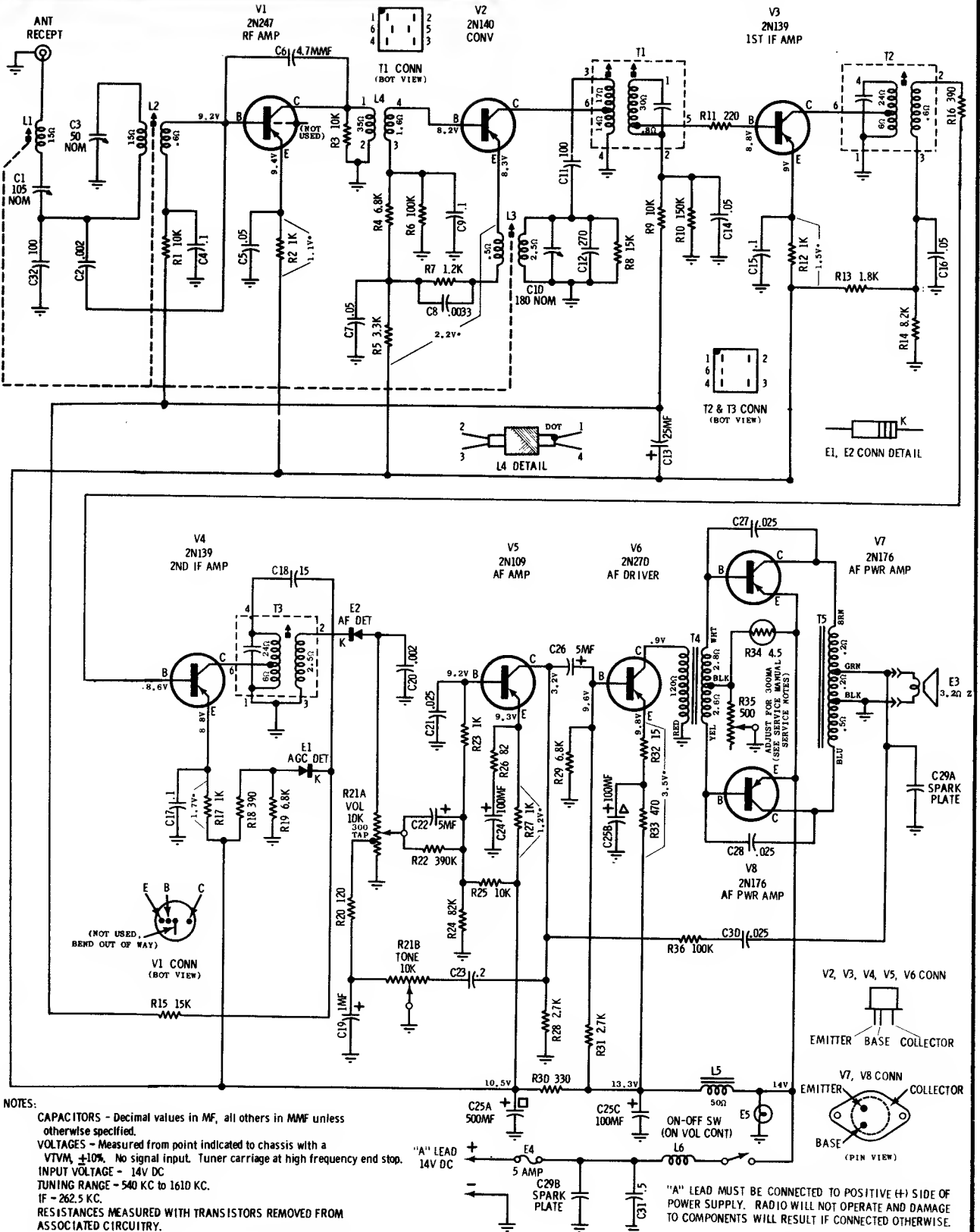

VOLUME R-19, MOST-OFTEN-NEEDED 1959 RADIO SERVICING INFORMATION

MOTOROLA Model GV-800, Alignment Adjustments & Parts Location. Continued.

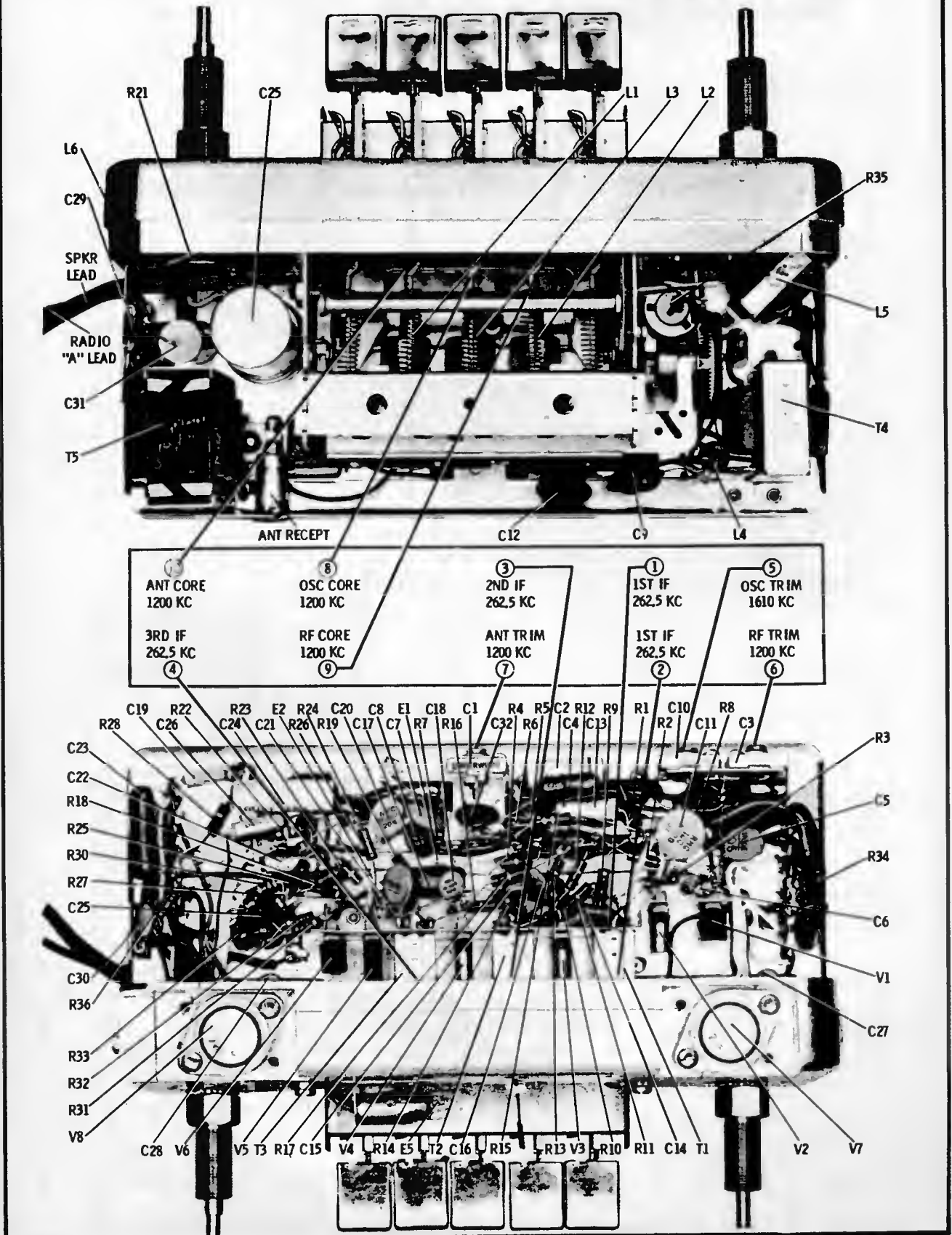

MOTOROLA

MODELS	CHASSIS
5P21B	HS-633
5P21N	HS-633
5P21R	HS-633

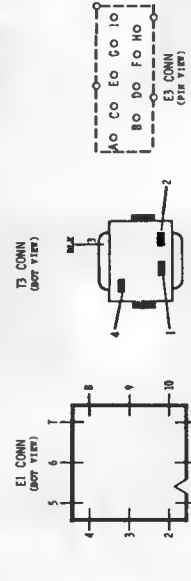
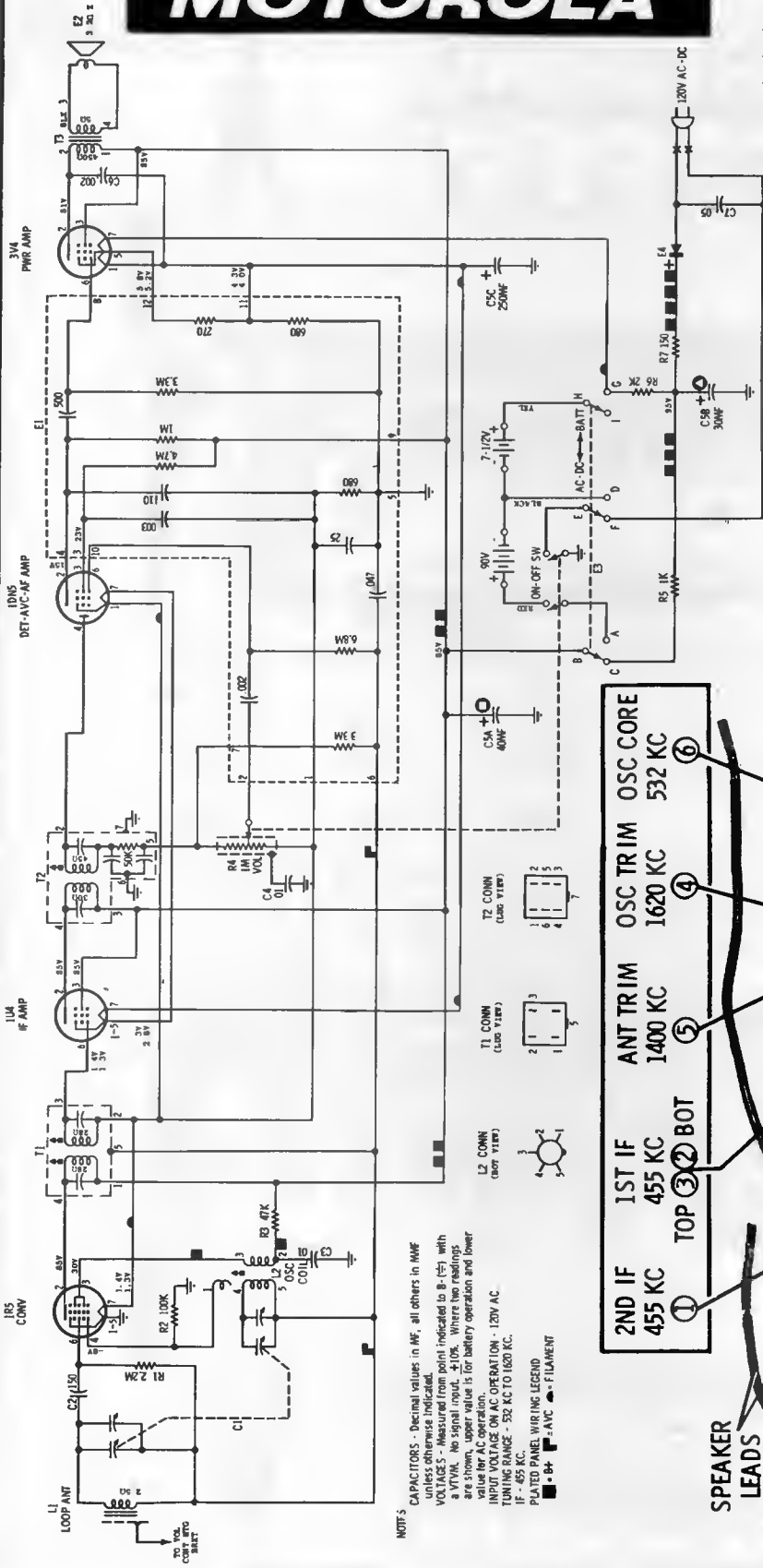

- TO REMOVE CHASSIS FROM CABINET**
1. Pull the control knobs from front of radio.
 2. Remove the volume control mounting palmnut and the machine screws under tuning knob of radio.
 3. Unsolder speaker leads.
 4. Unsolder antenna leads.
 5. Remove chassis from cabinet.

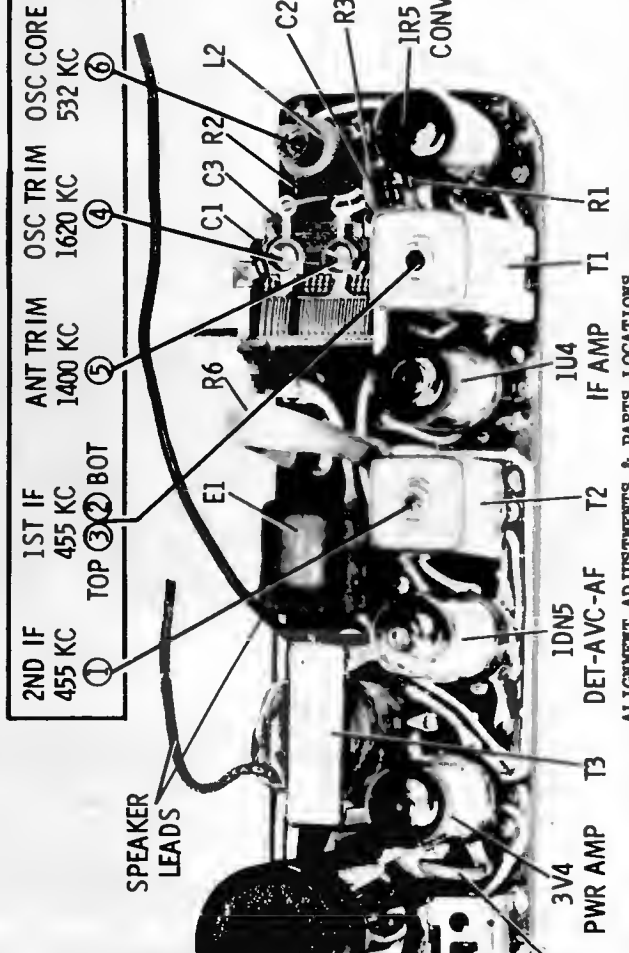

NOTES - CAPACITORS - Decimal values in μF , all others in MMF unless otherwise indicated.
 - RESISTORS - Values in ohms from point indicated by B, F, or Ω with a μ or M . No sign in front of value is for 10^6 . Where no sign is shown, upper value is for battery operation and lower value for AC operation.
 - INPUT VOLTAGE ON AC OPERATION - 120V AC
 - TUNING RANGE - 532 KC TO 1620 KC.
 - IF - 455 KC.
PLATED PANEL WIRING LEGEND
 ■ - BH ■ - AVC ■ - FILAMENT

ALIGNMENT ADJUSTMENTS & PARTS LOCATIONS

MOTOROLA

MODELS	CHASSIS
6P25E	HS-637
6P25N	HS-637
6P25S	HS-637

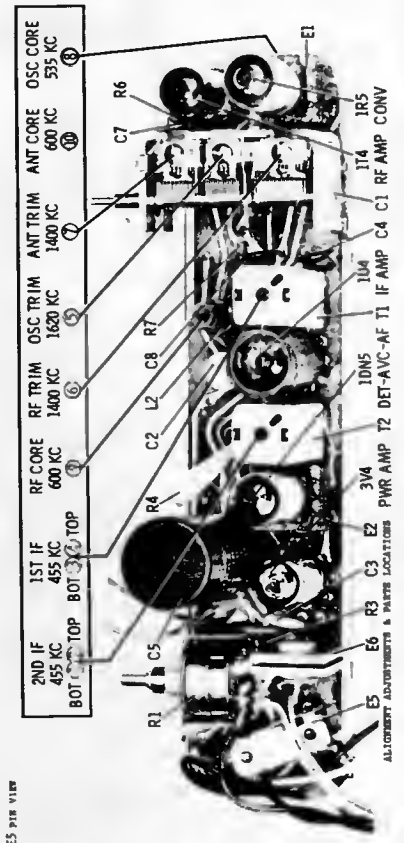
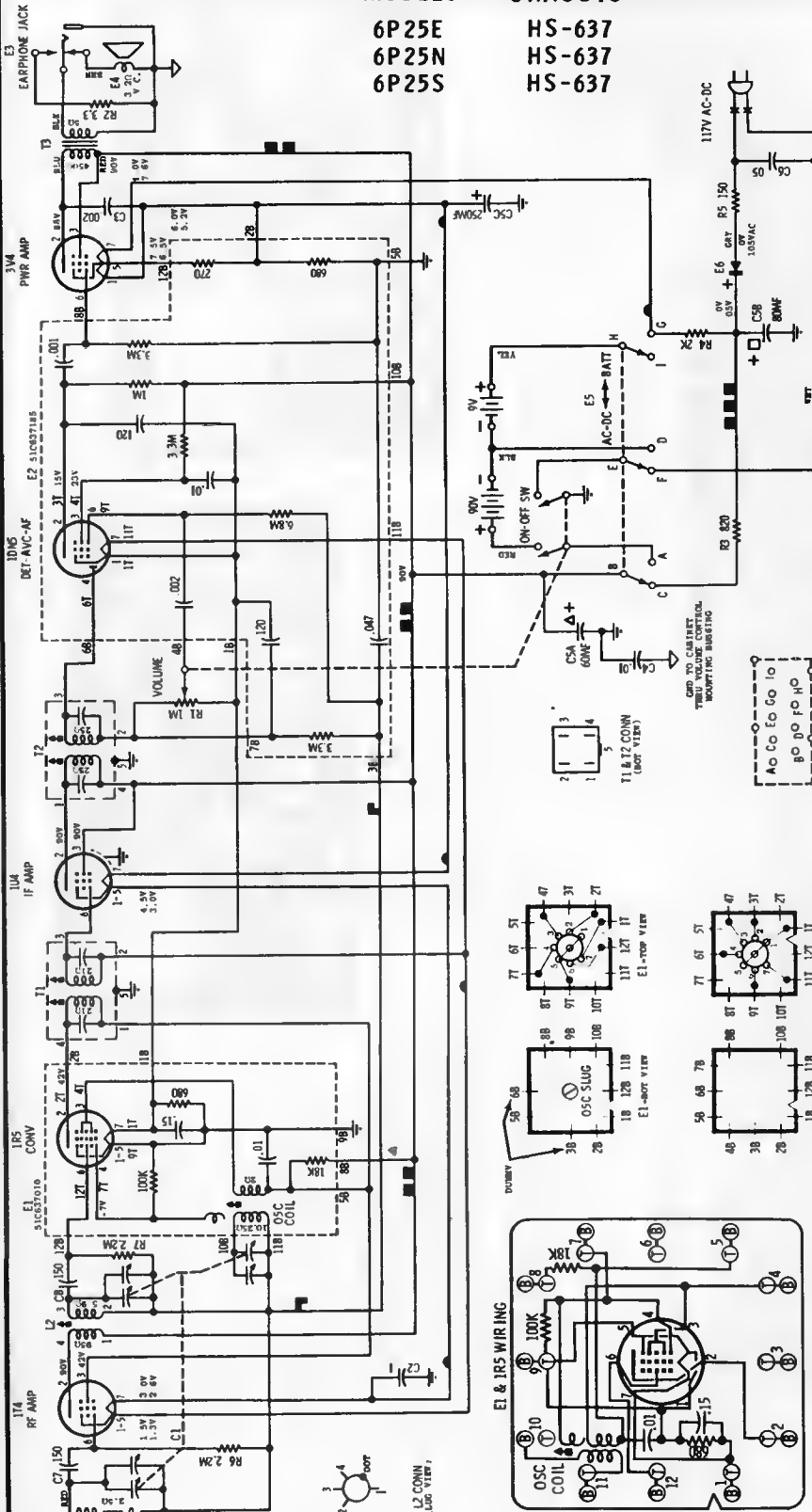

COMPONENT	VALUE
2ND IF	455 KC
1ST IF	455 KC
RF CORE	600 KC
RF TRIM	1400 KC
OSC TRIM	1600 KC
ANT TRIM	1400 KC
OSC CORE	555 KC
OSC CORE	555 KC

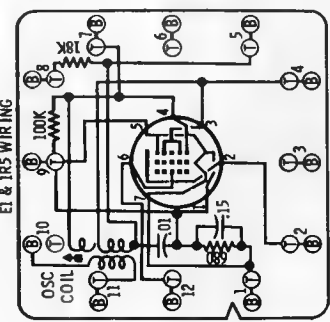
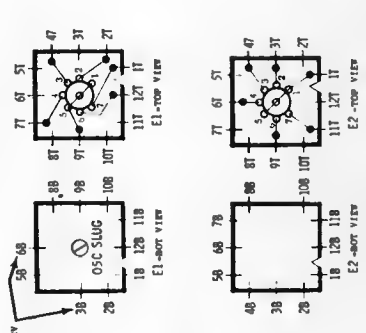

NOTES:

- CAPACITORS - Decimal values in MF, all others in MUF unless otherwise specified.
- VOLTAGES - Measured from point indicated to ground with a VTVM $\pm 10\%$. No signal input. Where two voltages are shown, upper value is for battery operation and bottom value for AC operation.
- INPUT VOLTAGE ON AC OPERATION - 117V AC.
- TUNING RANGE - 555 KC to 1600 KC.
- I.F. - 455 KC.
- \square = GROUND TO CABINET.
- \square = B-

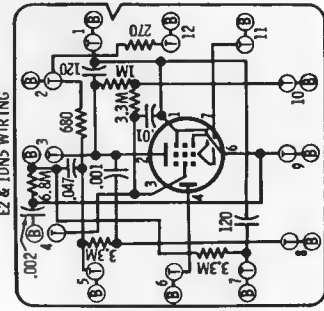

NOTES:

- B INDICATES CONNECTION TO BOTTOM OF MODULE;
- T INDICATES CONNECTION TO TOP OF MODULE.

MOTOROLA

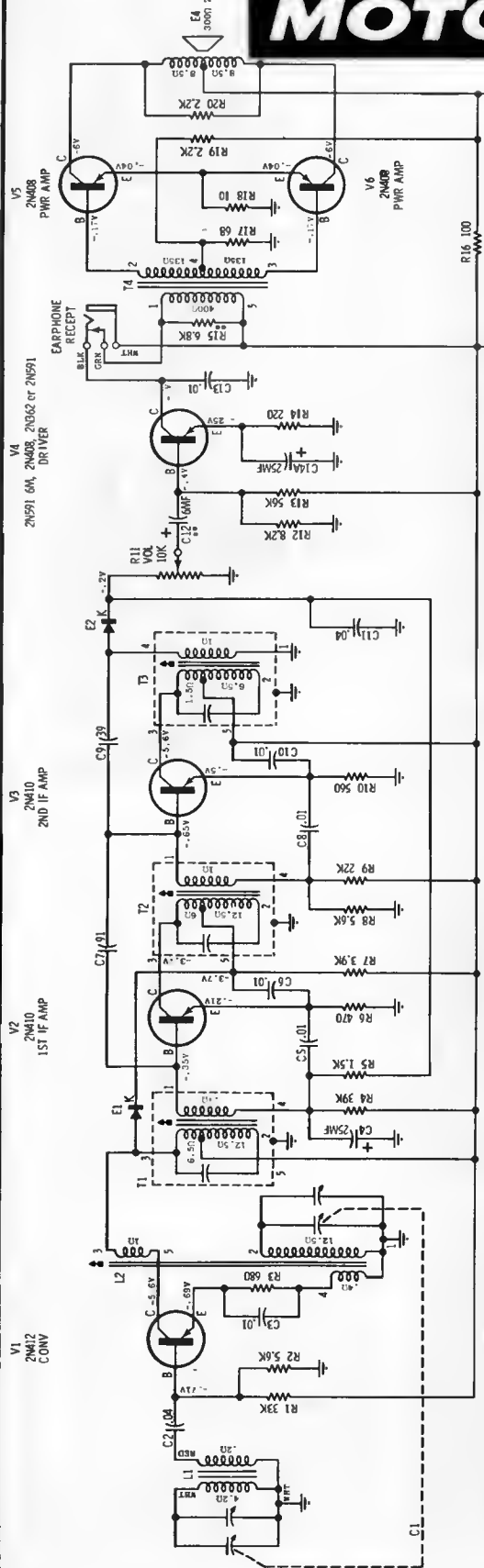

MOTOROLA

MODELS
 6X28B
 6X28N
 6X28P
 6X28W

CHASSIS
 HS-638
 HS-638
 HS-638
 HS-638

Power 8 Series

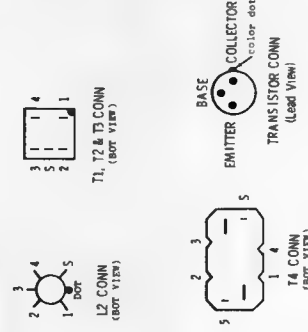

PLATED PANEL CHASSIS REMOVAL

1. Remove cabinet back by inserting a coin into the cover opening slot and twisting until cabinet back is free.
2. Remove earphone jack mounting nut and washer.
3. From inside cabinet, remove batteries.
4. Remove battery contact panels by pulling straight out (note position of rounded corners on panels to insure correct positioning when chassis is replaced later).
5. Spread cabinet slightly at top and bottom (points A & B) until chassis is free of chassis retainers (C & D) at top and bottom of cabinet; then lift up chassis at speaker end of cabinet until it clears the chassis retainers (C & D).
6. Lift chassis up until it is slightly above speaker, then slide chassis over speaker so that the chassis is free of chassis retainers (E & F) below earphone jack.
7. From under chassis, loosen speaker mounting screws until speaker mounting brackets are loose enough so that the speaker can be removed.
8. Lift chassis, speaker, and battery contact panels out of cabinet.
9. Before replacing chassis, mount speaker, then insert tuning gang end of chassis into cabinet, spread points A & B of cabinet, then lower other end of chassis into place under chassis retainers C & D (make certain battery leads are dressed under and away from antenna).
10. Place battery contact panels back into the cabinet slots with rounded corners of each panel facing in the same direction as originally found.

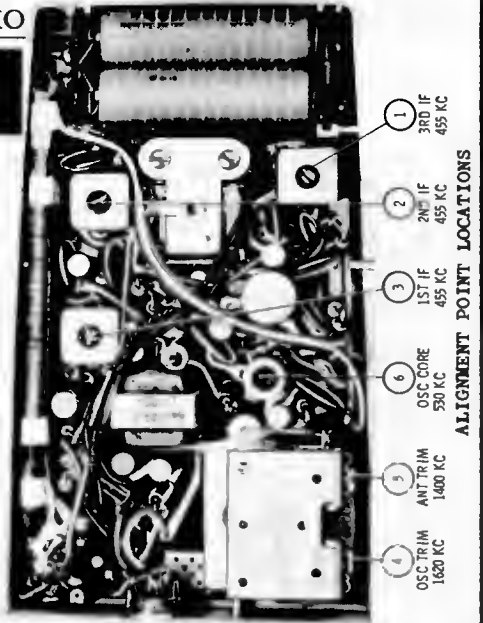

ALIGNMENT POINT LOCATIONS

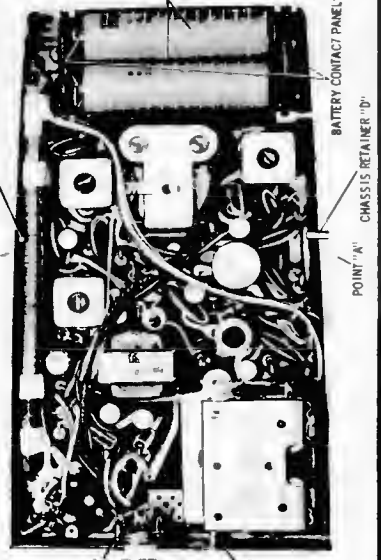

REMOVAL OF PLATED PANEL CHASSIS

MOTOROLA

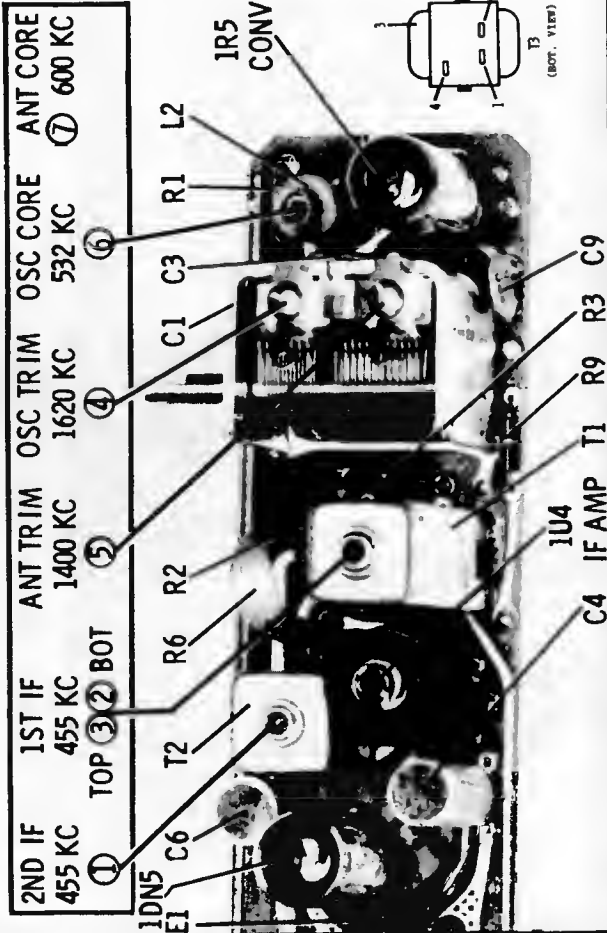
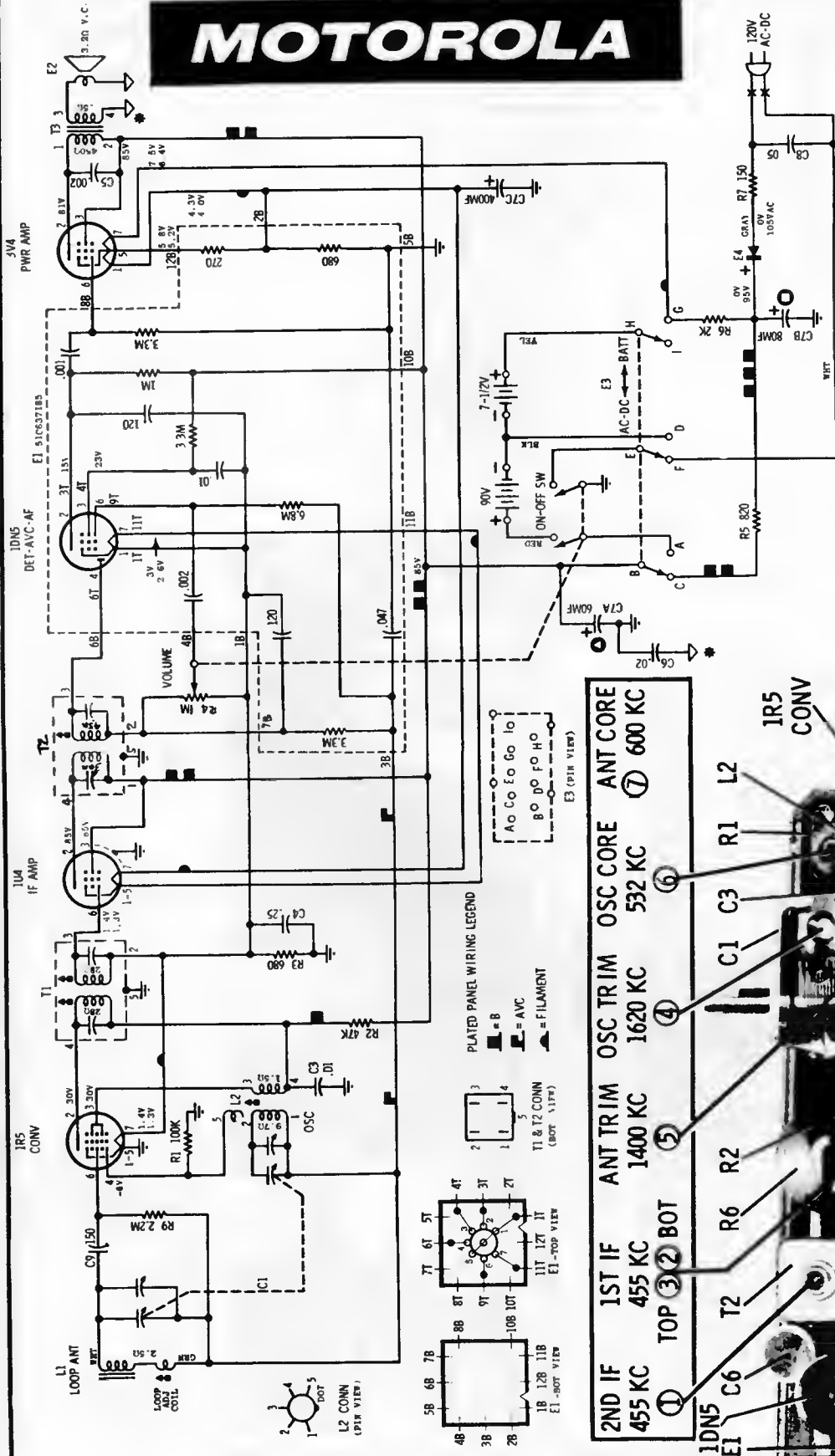

MOTOROLA

MODELS	CHASSIS
5P22GW-1	HS-647
5P22RW-1	HS-647
5P22S-1	HS-647
5P23E-1	HS-647
5P23PN-1	HS-647
5P23WB-1	HS-647

NOTES:

CAPACITORS - Decimal values in MF, all others in MMF unless otherwise specified.

VOLTAGES - Measured from point indicated to ground with a VTVM. No signal input.

10k tolerance. Where two voltage readings are shown, upper value is for battery operation and bottom value for AC operation.

INPUT VOLTAGE ON AC OPERATION - 120VAC.

TUNING RANGE - 532 KC to 1620 KC.

IF - 455 KC.

⊕ = B-; ⊖ = Ground to cabinet

* Ground to cabinet thru volume control mounting bushing.

VOLUME R-19, MOST-OFTEN-NEEDED 1959 RADIO SERVICING INFORMATION

MOTOROLA

MODELS	CHASSIS
5T11G	HS-652
5T11M	HS-652
5T11R	HS-652
5T11W	HS-652

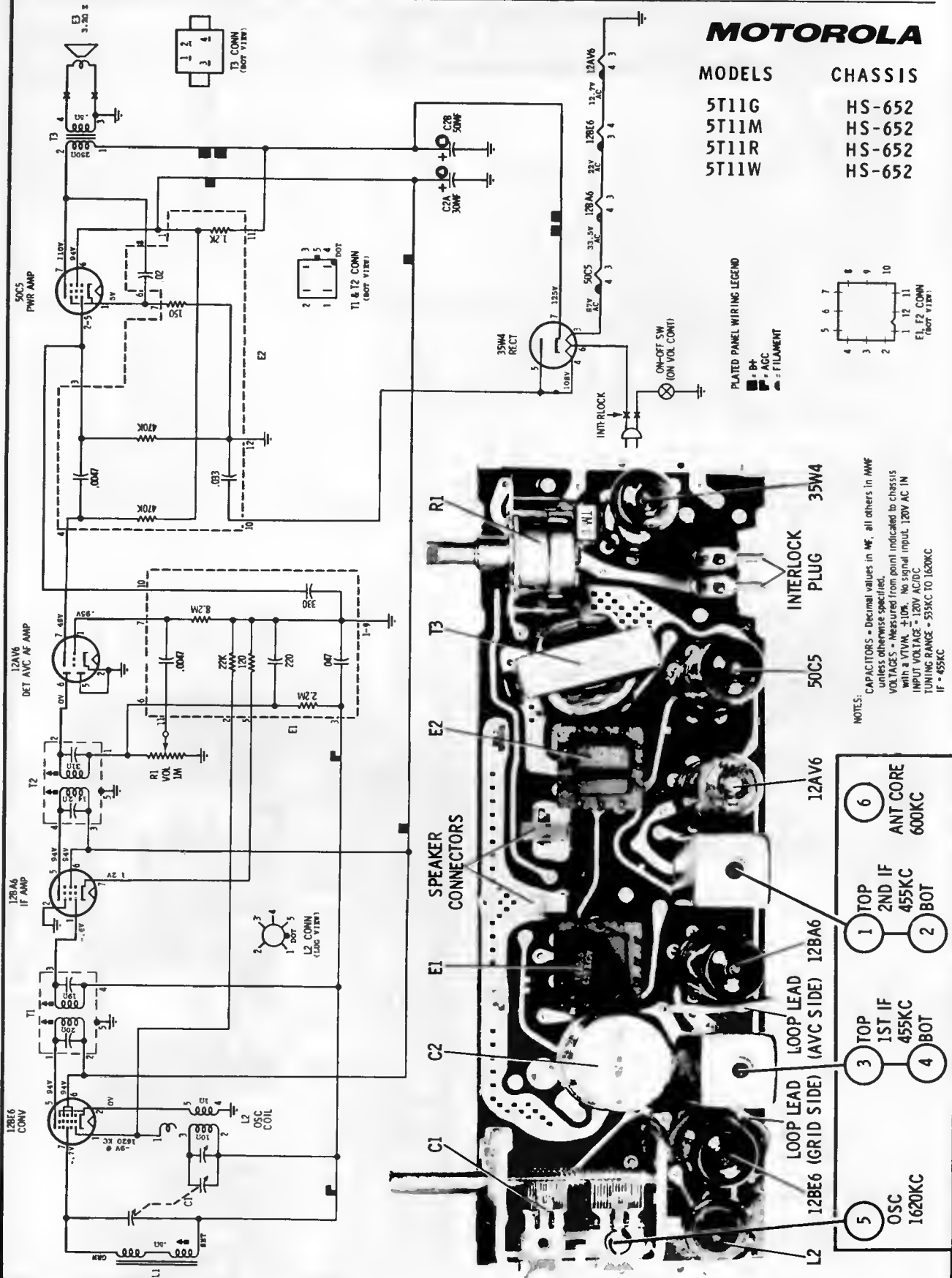

PLATED PANEL WIRING LEGEND

- = B+
- = ACC
- = FILAMENT

NOTES:
 CAPACITORS = Decimal values in μF , all others in MW unless otherwise specified.
 VOLTAGES = Measured from point indicated to chassis with a VTVM, $\pm 10\%$. No signal input. 120V AC IN INPUT VOLTAGE = 120V AC/0°C
 TUNING RANGE = 535KC TO 1620KC IF = 455KC



VOLUME R-19, MOST-OFTEN-NEEDED 1959 RADIO SERVICING INFORMATION

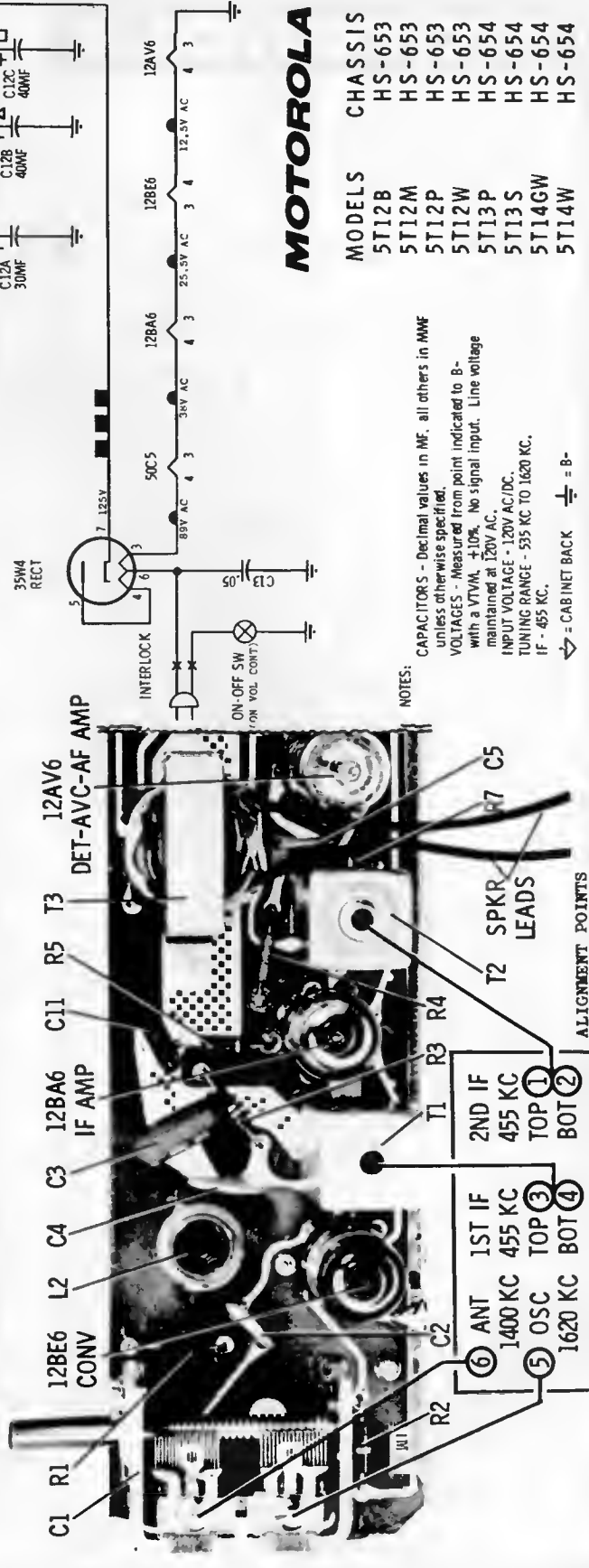
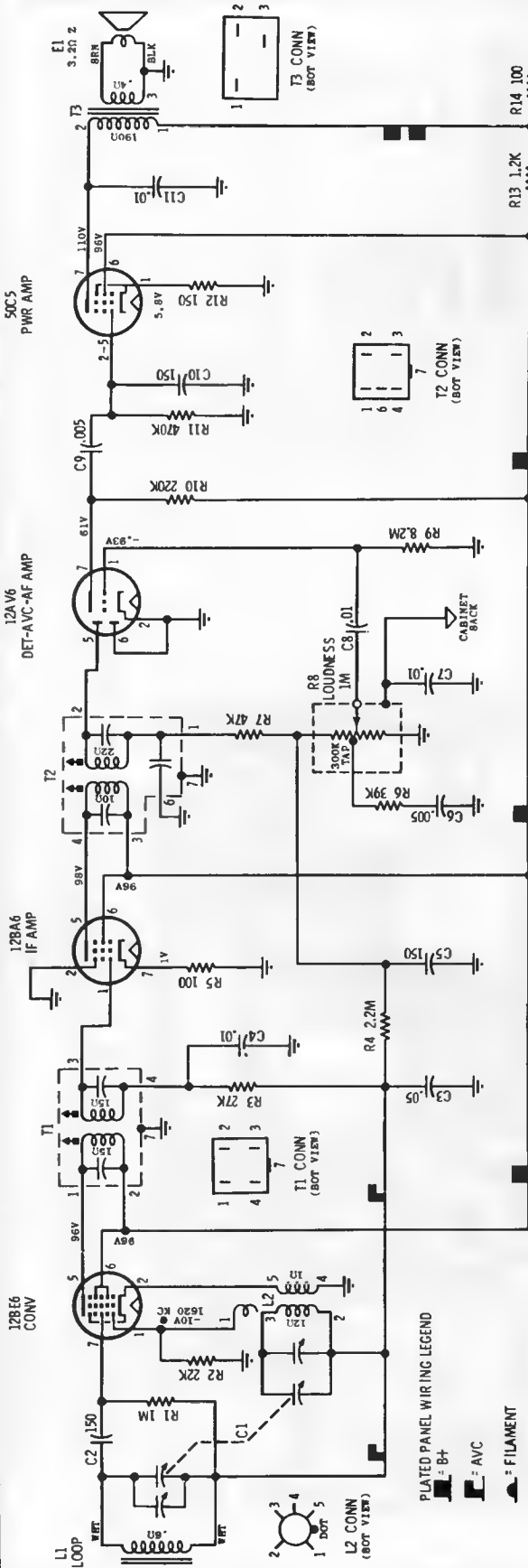

MOTOROLA

MODELS	CHASSIS
5T12B	HS-653
5T12M	HS-653
5T12P	HS-653
5T12W	HS-653
5T13P	HS-654
5T13S	HS-654
5T14GW	HS-654
5T14W	HS-654

NOTES:
 CAPACITORS - Decimal values in MF, all others in MMF unless otherwise specified.
 VOLTAGES - Measured from point indicated to B+ with a VTVM, ±10%. No signal input. Line voltage maintained at 120V AC.
 INPUT VOLTAGE - 120V AC/DC.
 TUNING RANGE - 535 KC TO 1620 KC.
 IF - 455 KC.
 ⇨ = CABINET BACK ⊕ = B-

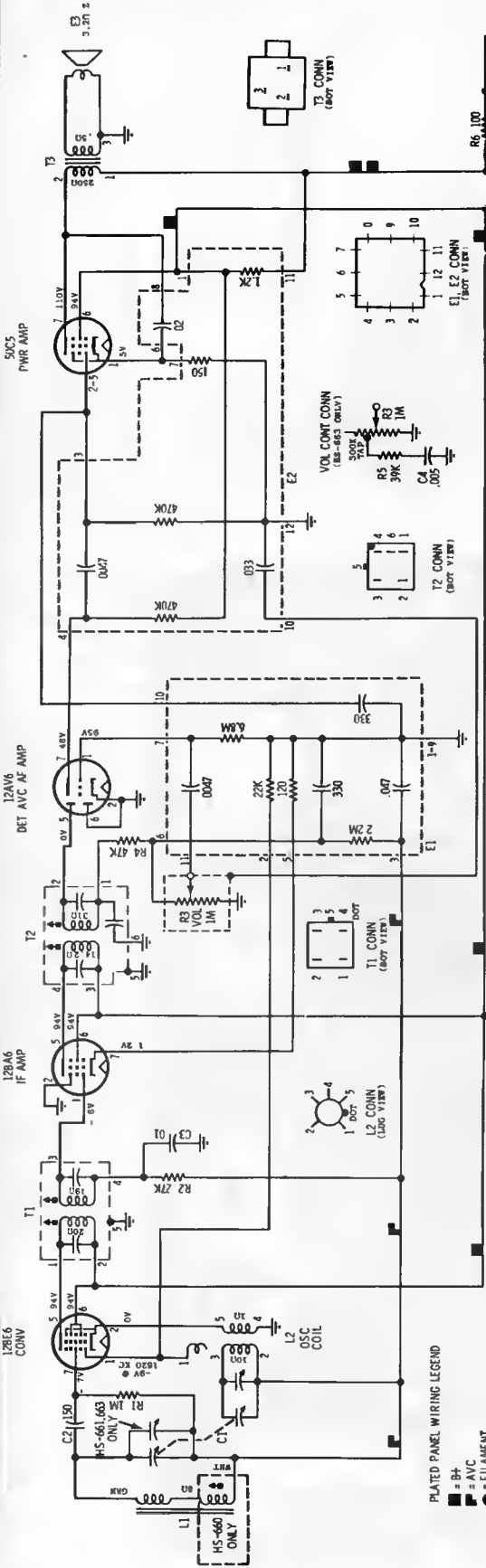

NOTES

CAPACITORS - Decimal values in MF, all others in MWF unless otherwise specified.

VOLTAGES - Measured from point indicated in chassis with a VTVM $\pm 10\%$. No signal input.

INPUT VOLTAGE - 120V AC ONLY

TUNING RANGE - 532KC TO 1620KC IF - 455KC

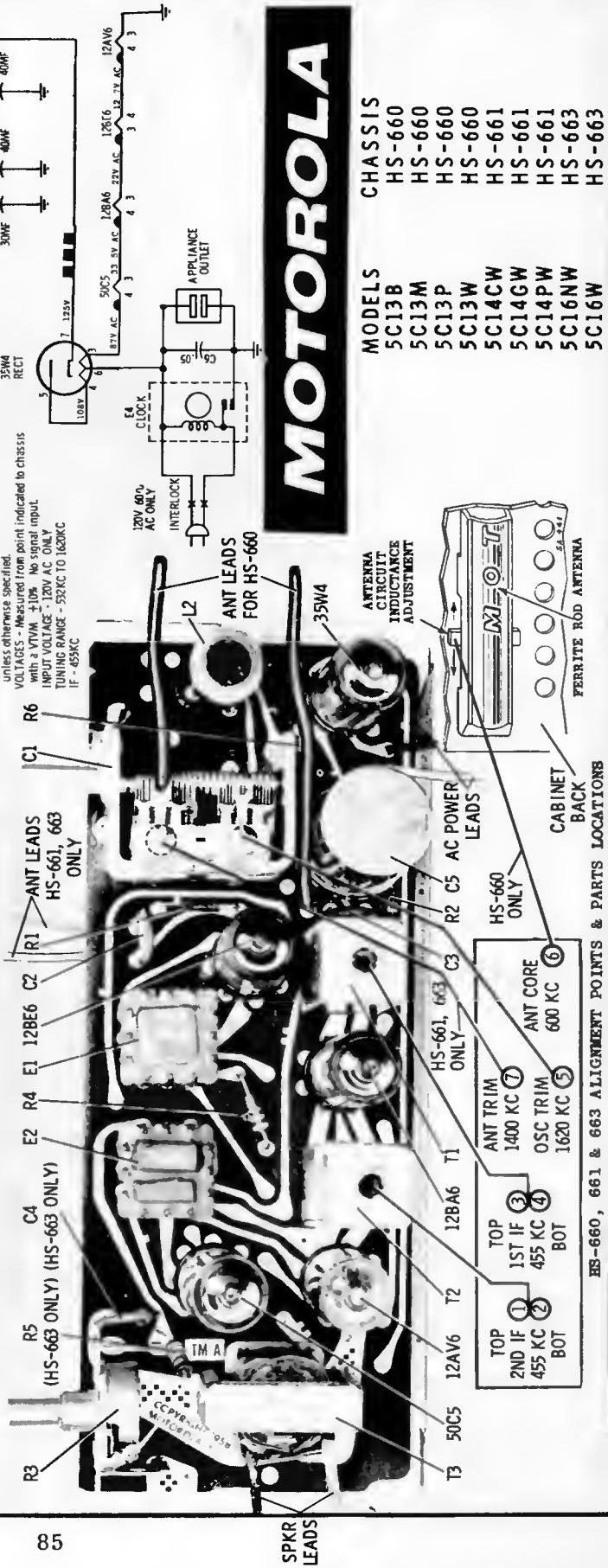

MOTOROLA

MODELS	CHASSIS
5C13B	HS-660
5C13M	HS-660
5C13P	HS-660
5C13W	HS-660
5C14CW	HS-661
5C14GW	HS-661
5C14PW	HS-661
5C16NW	HS-663
5C16W	HS-663

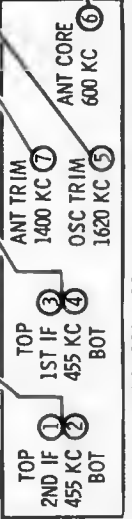

HS-660, 661 & 663 ALIGNMENT POINTS & PARTS LOCATIONS

VOLUME R-19, MOST-OFTEN-NEEDED 1959 RADIO SERVICING INFORMATION

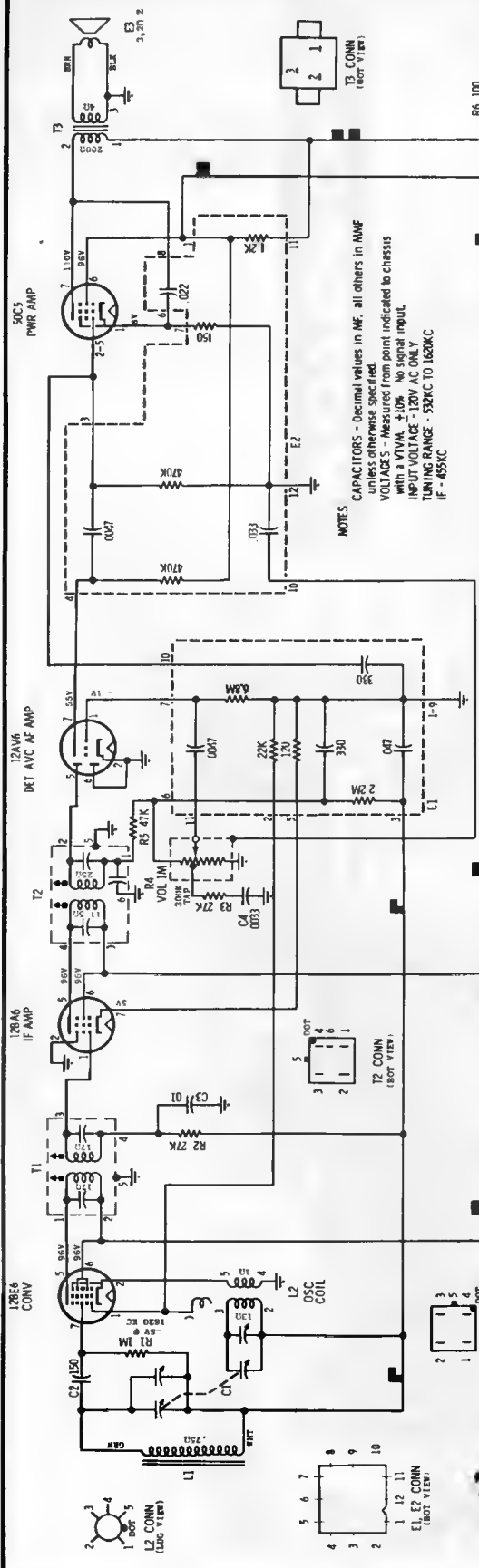

NOTES
 CAPACITORS - Decimal values in MF, all others in MMF unless otherwise specified.
 VOLTAGES - Measured from point indicated to chassis with a VPK - 500K. No signal input.
 INPUT VOLTAGE - 120V AC ONLY.
 TUNING RANGE - 530KC TO 1630KC
 IF - 455KC

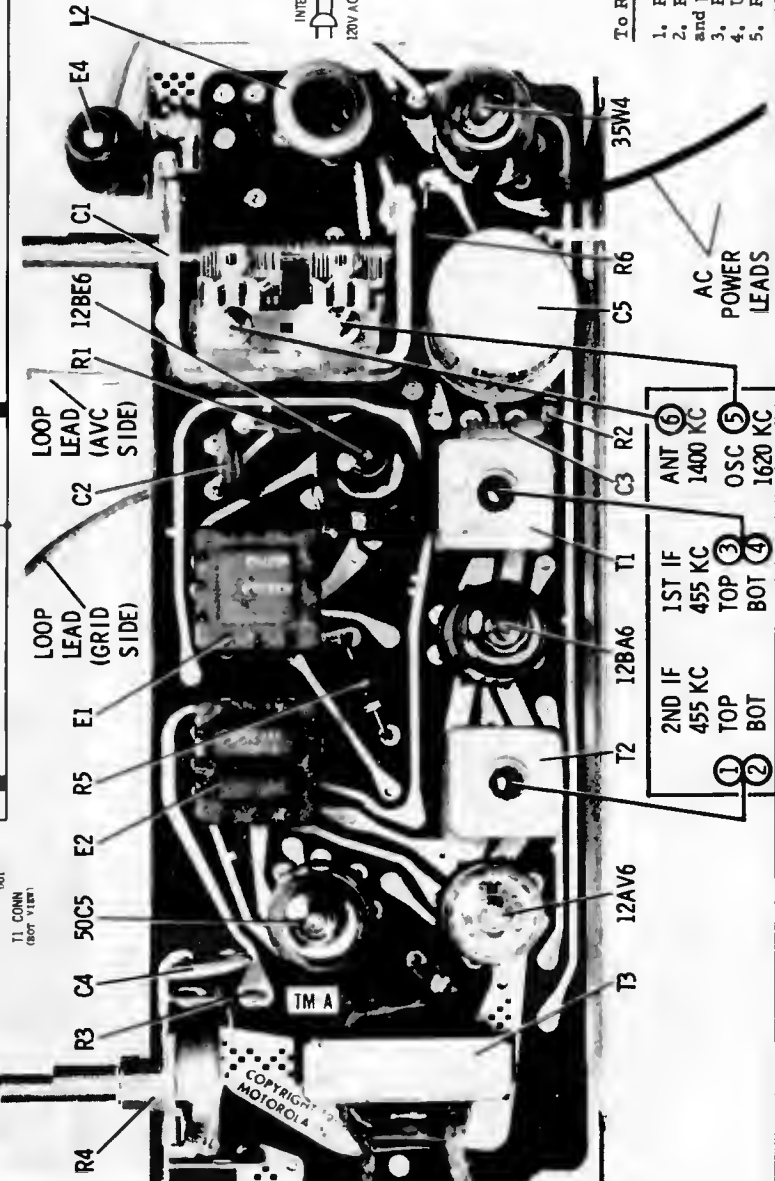

MOTOROLA
 MODELS 5C15BW, 5C15GW, 5C15VW
 CHASSIS HS-662, HS-662, HS-662

To Remove Chassis From Cabinet

1. Remove the dial scale, tuning and volume knobs.
2. From rear, remove the 2 rear cabinet mounting screws and pull out rear cabinet.
3. Remove the 4 chassis mounting screws.
4. Unsolder antenna, speaker, and AC power leads.
5. Remove chassis from cabinet.

MOTOROLA MODELS CHASSIS

2F12N HS-667
2F12W HS-667

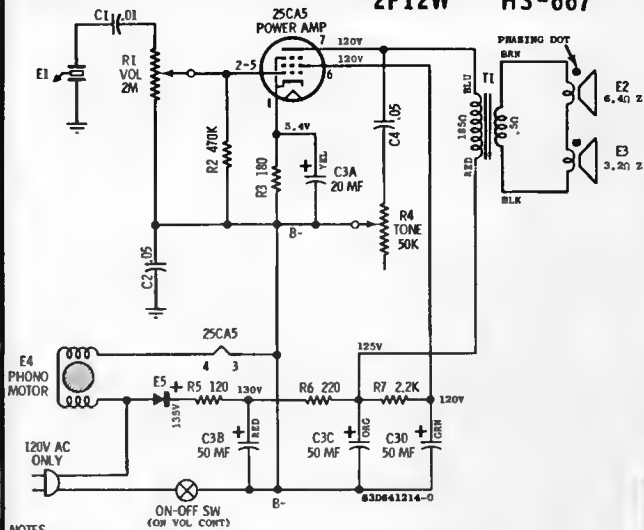

NOTES:

CAPACITORS - Decimal values in MF, all others in MMF unless otherwise specified.
VOLTAGES - Measured from point indicated to B- with a VTVM.

DISASSEMBLY INSTRUCTIONS

To Remove Chassis from Cabinet

1. Pull off two knobs from front of cabinet.
2. Remove four (4) motorboard and three (3) baffle retainer screws.
3. Remove baffle.
4. Lift rear of motorboard slightly and slide out.
5. Remove two screws which hold chassis to motorboard and remove chassis.

To Remove Turntable

1. Remove "C" washer from spindle.
2. Remove turntable by pulling up - off of spindle.

MODELS CHASSIS

2F11B HS-666
2F11R HS-666

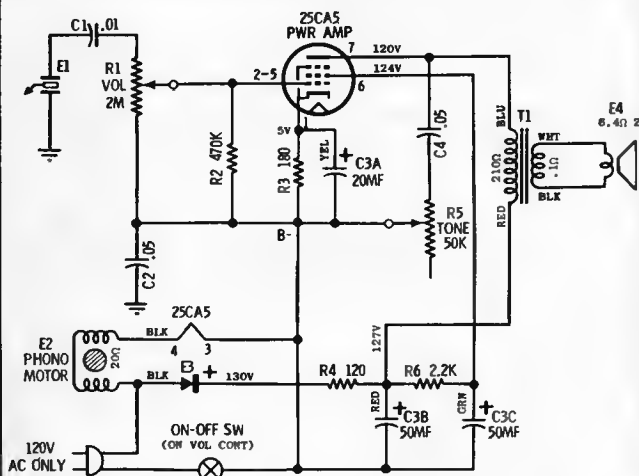

NOTES:

CAPACITORS - Decimal values in MF, all others in MMF unless otherwise specified.
VOLTAGES - Measured from point indicated to B- with a VTVM.
CHASSIS -

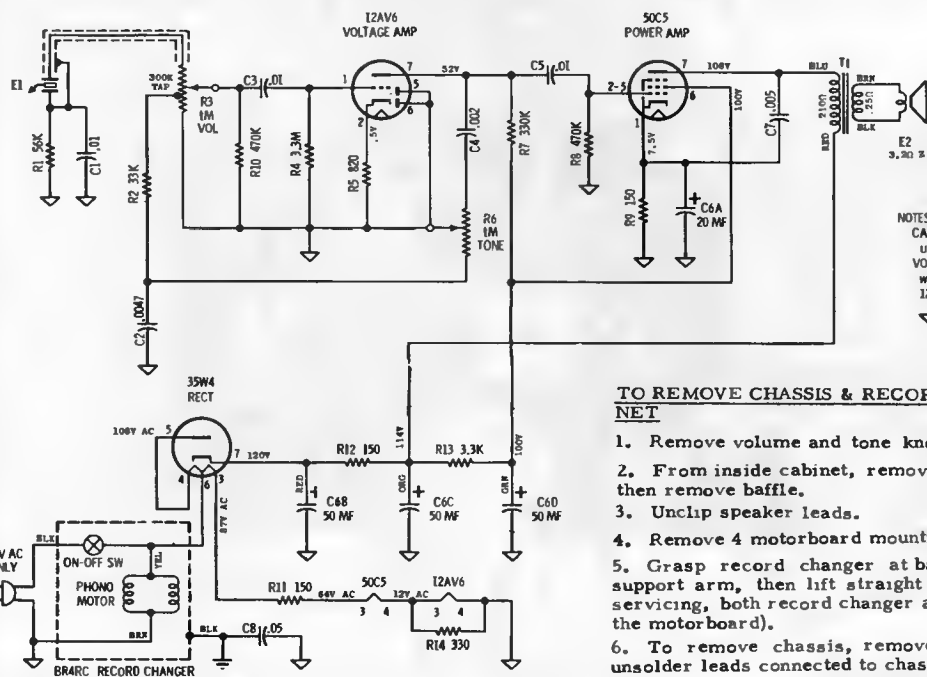
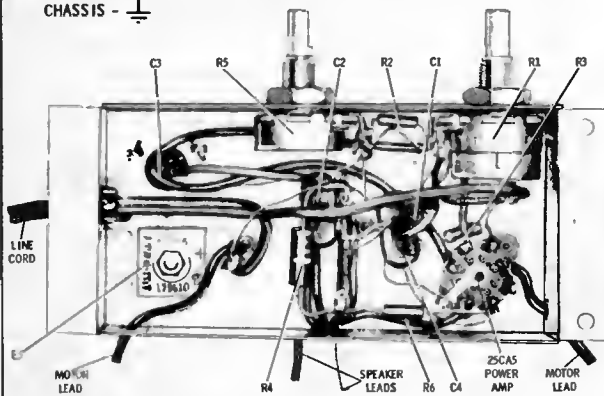

MOTOROLA

MODELS CHASSIS

3F13B HS-668
3F13W HS-668

NOTES

CAPACITORS - Decimal values in MF, all others in MMF unless otherwise specified.
VOLTAGES - Measured from point indicated to B- with a VTVM, $\pm 10\%$. Line Voltage maintained at 120V AC.

↖ = B- ⚡ = Chassis

TO REMOVE CHASSIS & RECORD CHANGER FROM CABINET

1. Remove volume and tone knobs.
2. From inside cabinet, remove 3 baffle mounting screws, then remove baffle.
3. Unclip speaker leads.
4. Remove 4 motorboard mounting screws.
5. Grasp record changer at base of tone arm and record support arm, then lift straight out of cabinet (to facilitate servicing, both record changer and chassis are mounted on the motorboard).
6. To remove chassis, remove 4 chassis mounting nuts; unsolder leads connected to chassis if necessary.

MOTOROLA

MODELS 5R14N
CHASSIS HS-670

To Remove Chassis From Cabinet

1. Pull off control knobs.
2. Remove 3 antenna panel mounting screws.
3. Remove antenna panel (disconnect line cord from interlock).
4. Disconnect antenna and speaker leads.
5. Remove 4 record changer board mounting screws.
6. Lift changer and mounting board up and out of the way.

7. Loosen 2 screws which hold interlock to cabinet; remove interlock from cabinet.
8. "Uncrimp" ends of chassis mounting brackets and melt solder at these points. CAUTION: Apply only enough heat to allow chassis to slide out of brackets; too much heat may damage the plated circuit board.
9. Slide chassis out of the brackets.
10. Disconnect record changer leads from chassis.

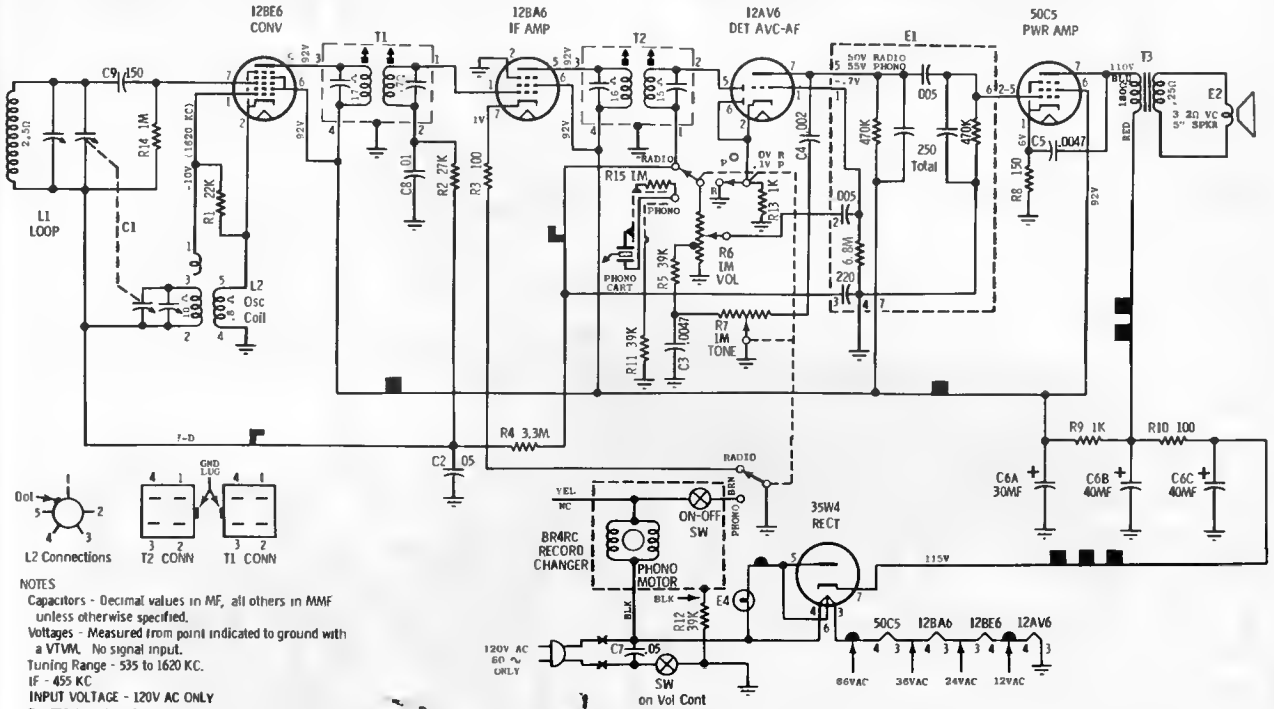

NOTES
 Capacitors - Decimal values in MF, all others in MMF unless otherwise specified.
 Voltages - Measured from point indicated to ground with a VTVM. No signal input.
 Tuning Range - 535 to 1620 KC.
 IF - 455 KC.
 INPUT VOLTAGE - 120V AC ONLY
 PLATED PANEL WIRING LEGEND
 ■ - B+ □ - AVC ▲ - FILAMENT

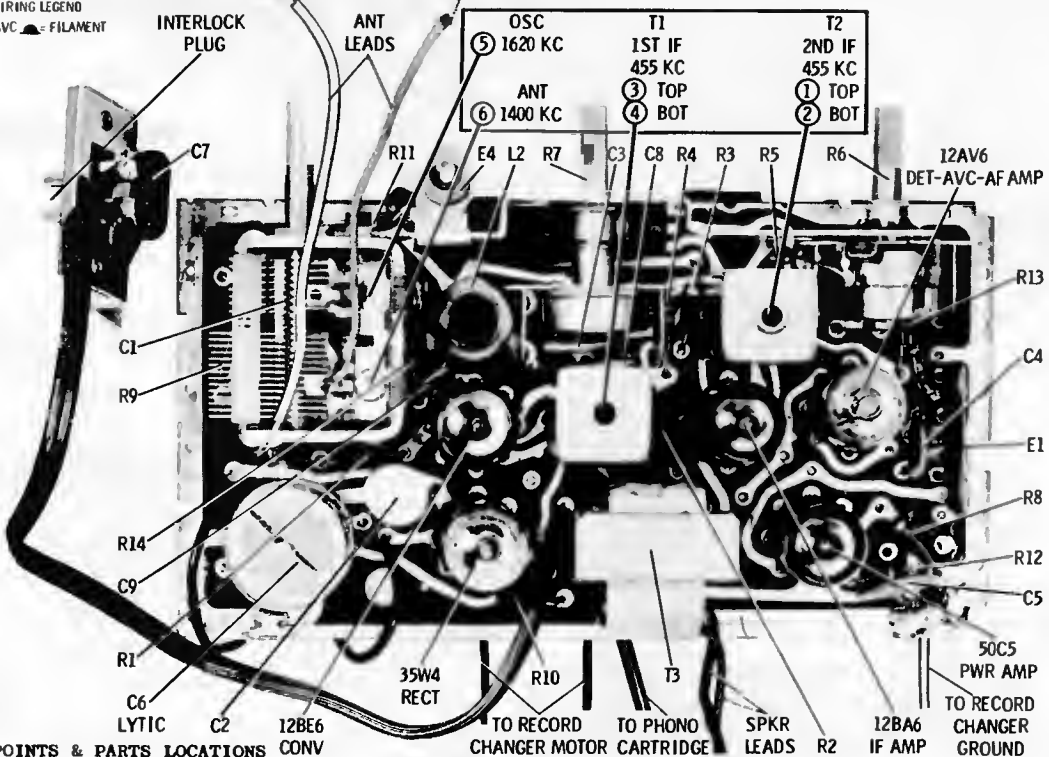

ALIGNMENT POINTS & PARTS LOCATIONS

MOTOROLA

MODELS	CHASSIS
5K11B	HS-673
5K11M	HS-673
5K11MC	HS-673
5K11W	HS-673

NOTES
 CAPACITORS - Decimal values in MF, all others in MWF unless otherwise specified.
 VOLTAGES - Measured from point indicated to chassis with a VTVM. $\pm 10\%$. No signal in.
 S1 & S2 conn details viewed from indicated sides with arrow indicating clockwise rotation as viewed from front of control
 S1 SHOWN IN PHONO POSITION IR IAAI
 S2 SHOWN IN EXT SPKR POSITION
 - Chassis - Record changer base

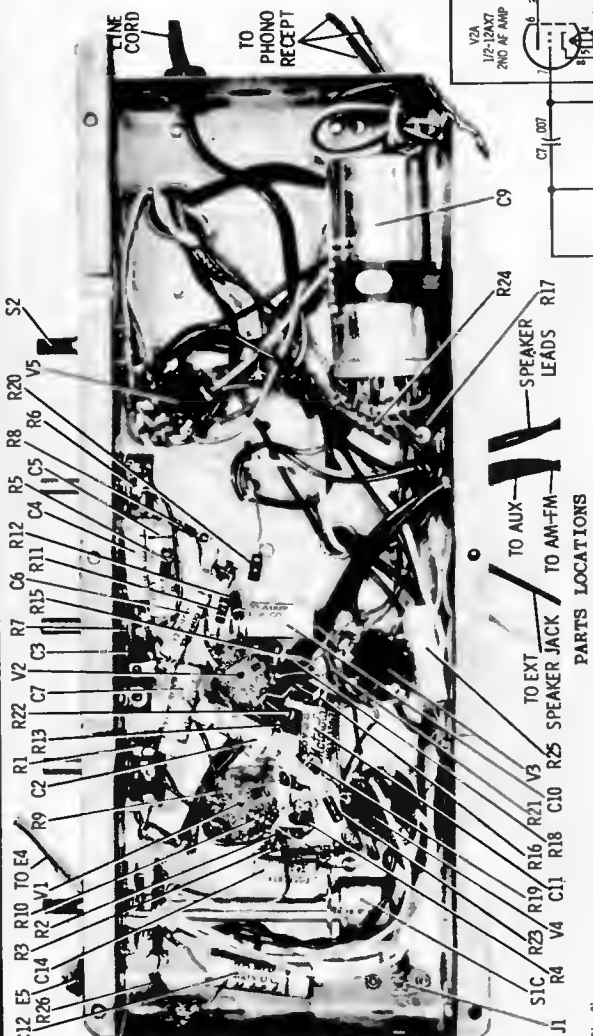

R1 R2 R3 R4 R5 R6 R7 R8 R9 R10 R11 R12 R13 R14 R15 R16 R17 R18 R19 R20 R21 R22 R23 R24 R25 R26
 C1 C2 C3 C4 C5 C6 C7 C8 C9
 V1 V2 V3 V4 V5 V6
 S1 S2
 TO PHONO RECEPT
 TO AUX - SPEAKER LEADS
 TO AM-FM JACK
 TO EXT SPEAKER JACK
 PARTS LOCATIONS

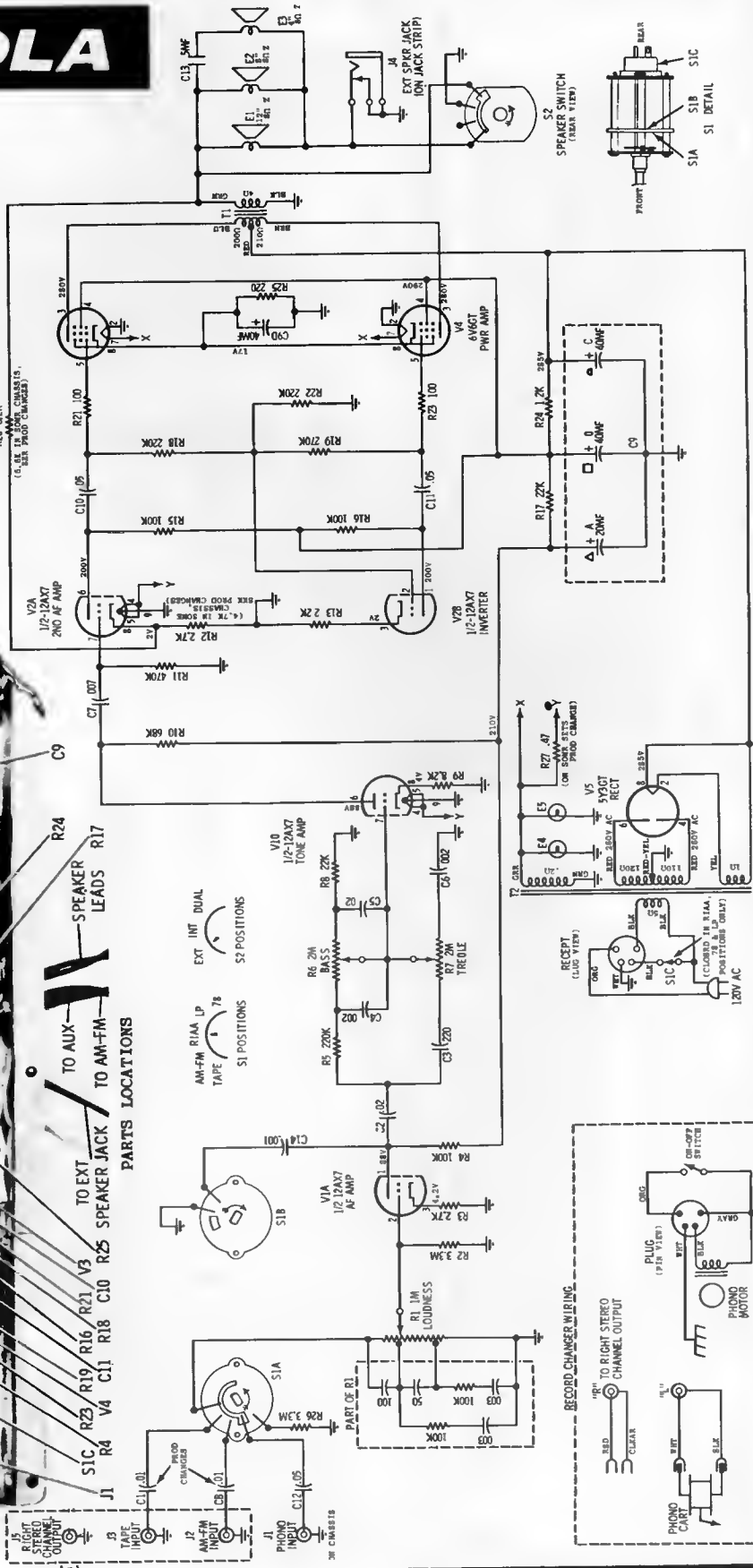

MOTOROLA

MODELS CHASSIS
 6K13B HS-675
 6K13CW HS-675
 6K13M HS-675
 6K13W HS-675

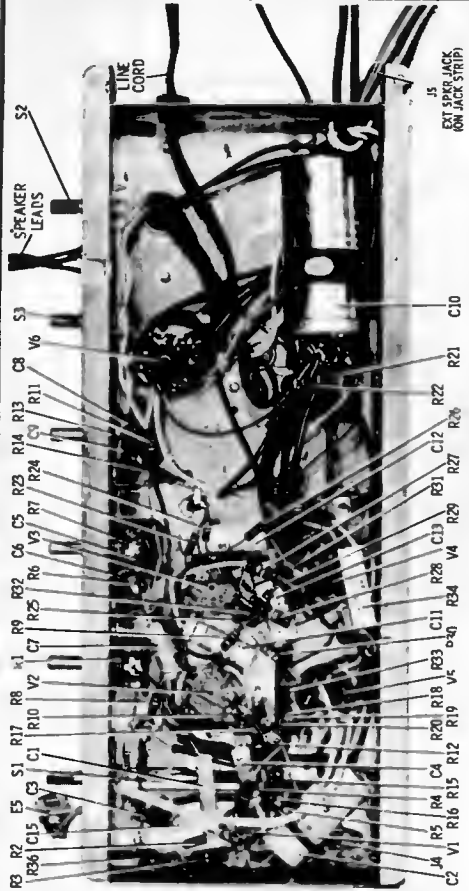

PARTS LOCATIONS

- To Remove Chassis From Cabinet**
1. Pull off the control knobs.
 2. Remove cabinet back cover.
 3. Disconnect leads from changer, auxiliary jacks and speakers.
 4. Remove light shield and pilot light socket.
 5. Remove three chassis mounting screws and remove chassis.

To Remove Record Changer From Cabinet

1. Remove back cover.
2. Disconnect all changer leads.
3. Turn the two record changer mounting screws fully clockwise (down flush against changer base).
4. From bottom of changer, turn the two Timmerman nuts located at mounting screw ends so they are parallel with the screws.
5. Grasp changer by base and lift up.

To Replace Pilot Lights

1. To replace pilot light in record changer compartment, remove light shield, then bulb.
2. To remove pilot light on chassis, first remove chassis (see above), then bulb.

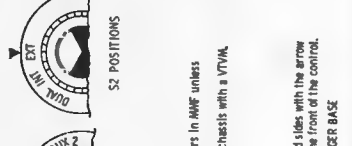
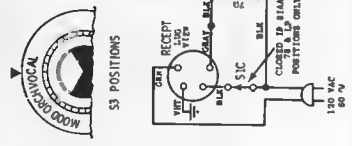
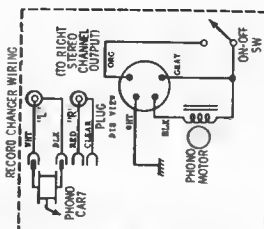
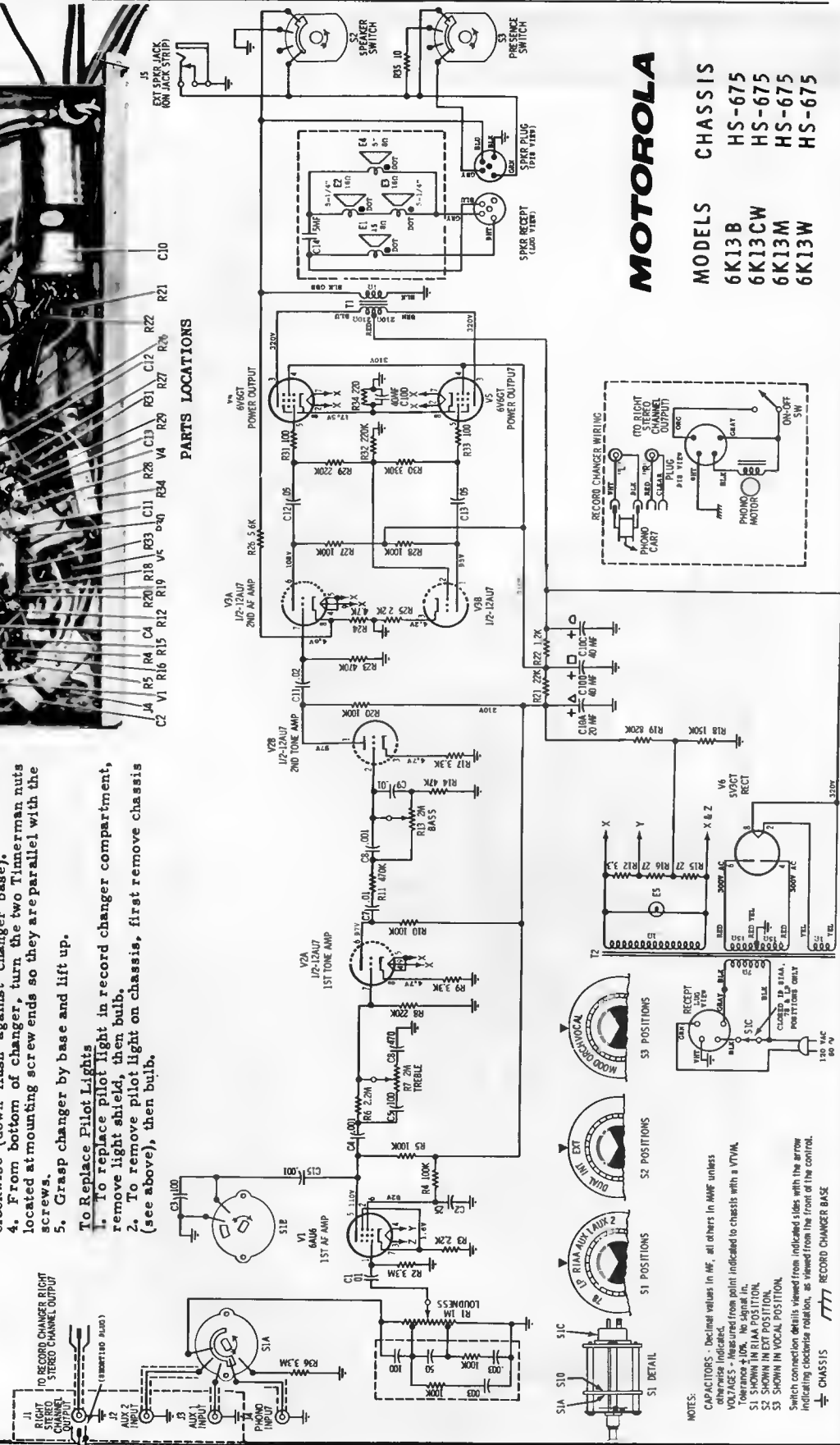

NOTES:
 CAPACITORS - Decimal values in MF; all others in MMF unless otherwise indicated.
 VOLTAGES - Measured from point indicated to chassis with a VTVM.
 S1 SHOWN IN R1A POSITION.
 S2 SHOWN IN EXT POSITION.
 S3 SHOWN IN VOCAL POSITION.
 Switch connection details viewed from indicated sides with the arrow indicating clockwise rotation, as viewed from the front of the control.

VOLUME R-19, MOST-OFTEN-NEEDED 1959 RADIO SERVICING INFORMATION

MOTOROLA

MODELS
8X26E
8X26S

CHASSIS
HS-679
HS-679

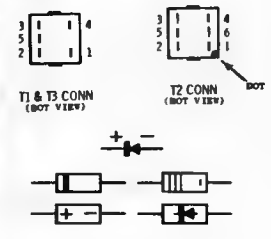
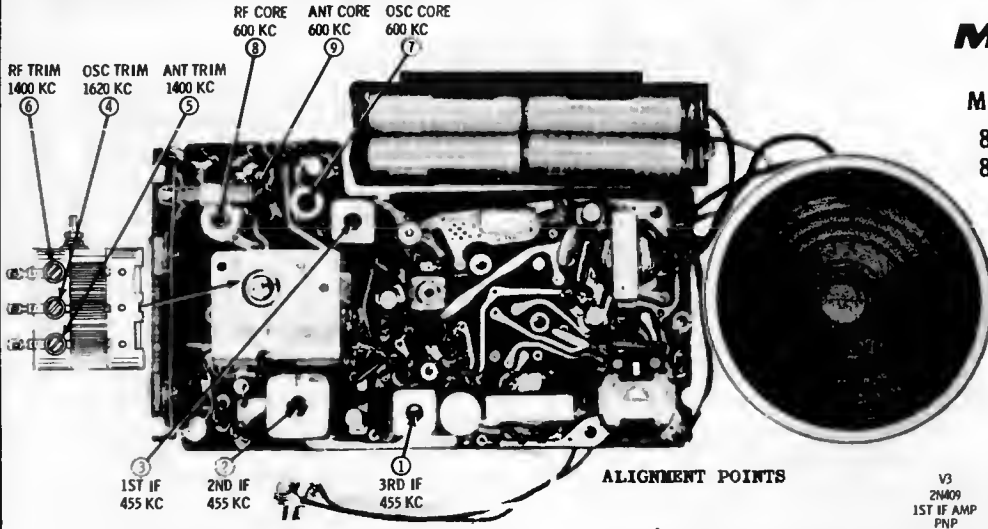

ALIGNMENT POINTS

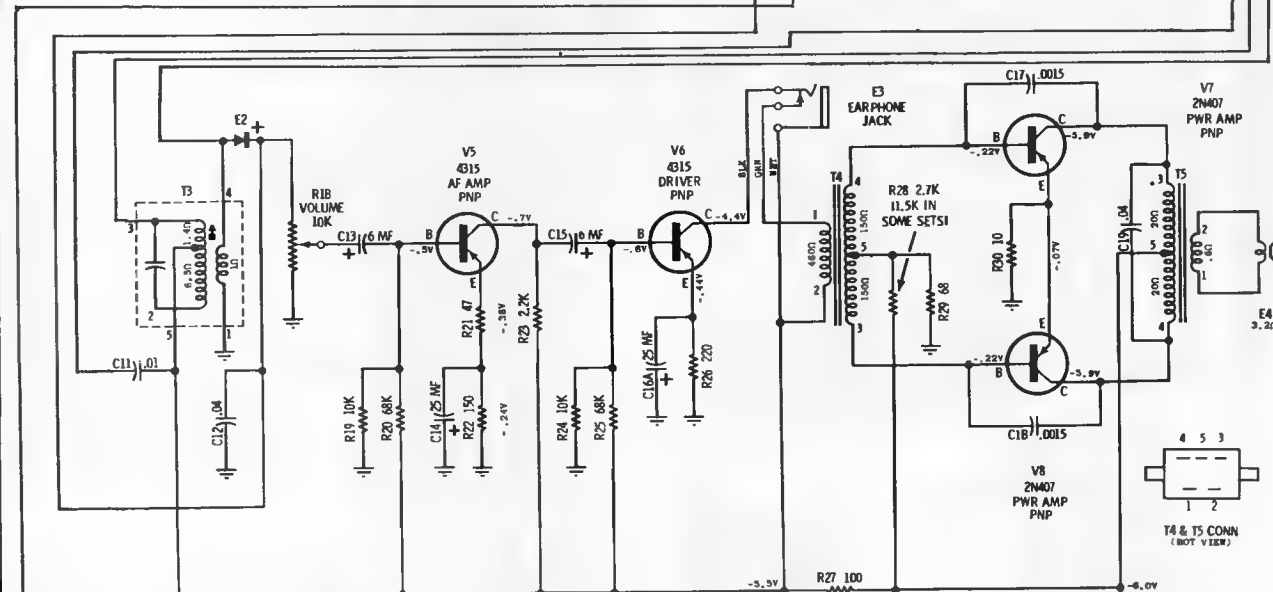
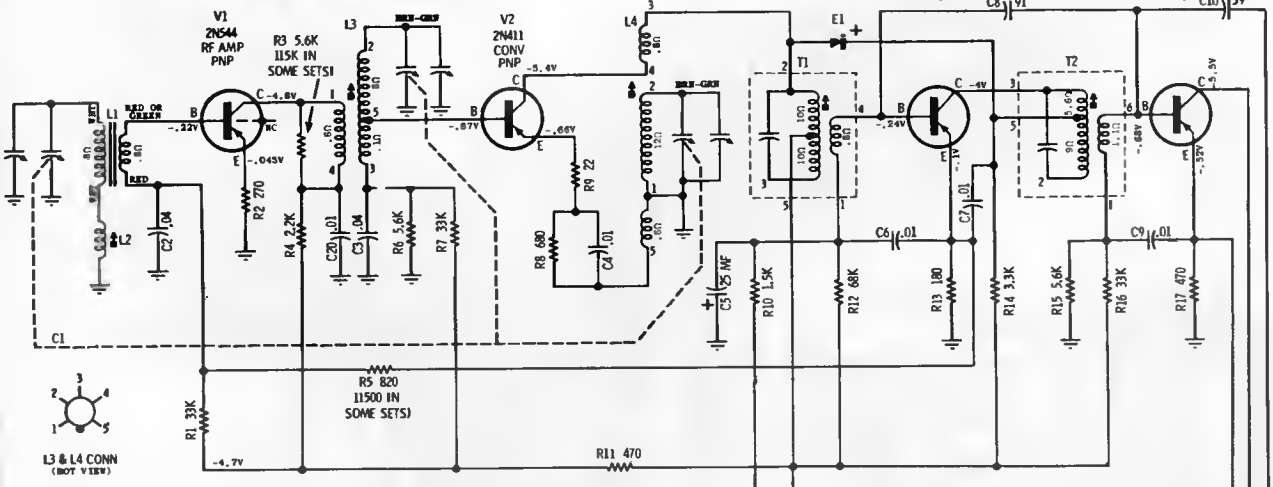

CAPACITORS - Decimal values in MF, all others in MMF unless otherwise specified.
 VOLTAGES - Measured from point indicated to ground with a VTVM, $\pm 10\%$. No signal in.
 TUNING RANGE - 535 KC to 1620 KC.
 IF - 455 KC.
 Resistances measured with transistors removed from associated circuitry.

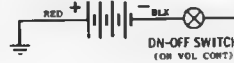
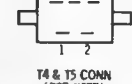

MOTOROLA

MODELS	CHASSIS
7X23E	HS-688
7X24S	HS-688
7X24W	HS-688

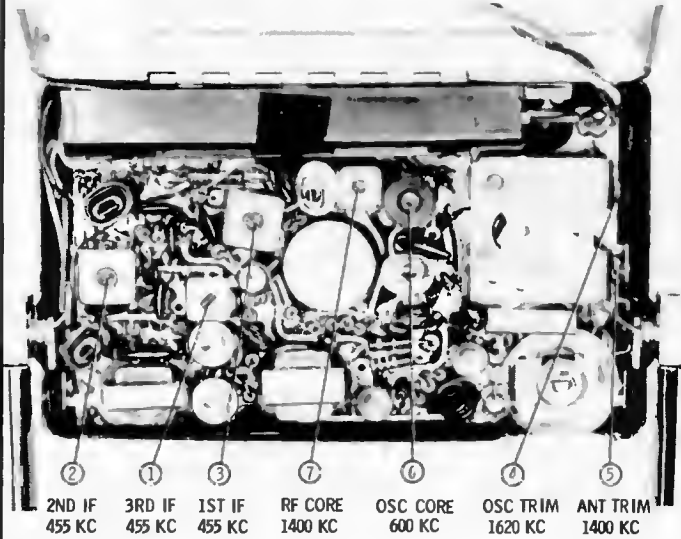

2ND IF 455 KC 3RD IF 455 KC 1ST IF 455 KC RF CORE 1400 KC OSC CORE 600 KC OSC TRIM 1620 KC ANT TRIM 1400 KC

ALIGNMENT POINT LOCATIONS

ESCUTCHEON & CHASSIS REMOVAL

1. From inside cabinet (below gang) remove escutcheon mounting screw.
2. Remove escutcheon by inserting small screwdriver into detent on edge of escutcheon and prying up. Work escutcheon free (use caution to prevent scratching cabinet and escutcheon.)
3. Remove dial and tuning knobs by pulling straight off.
4. Remove chassis mounting screw.
5. Turn handle perpendicular to component side of plated panel.
6. Grasp handle near one of its two mounting bushings and pull out from side of cabinet until the round portion of mounting bushing clears hole in side of cabinet, then lift this side of handle and chassis slightly out of cabinet. Perform the same procedure on the other mounting bushing, then lift handle, chassis and speaker plate out of cabinet.
7. Unscrew earphone jack.
8. Separate the plated chassis from the speaker mounting plate as follows: unsolder the wire that connects the gang to the plated chassis. Unsolder speaker lug, green lead from

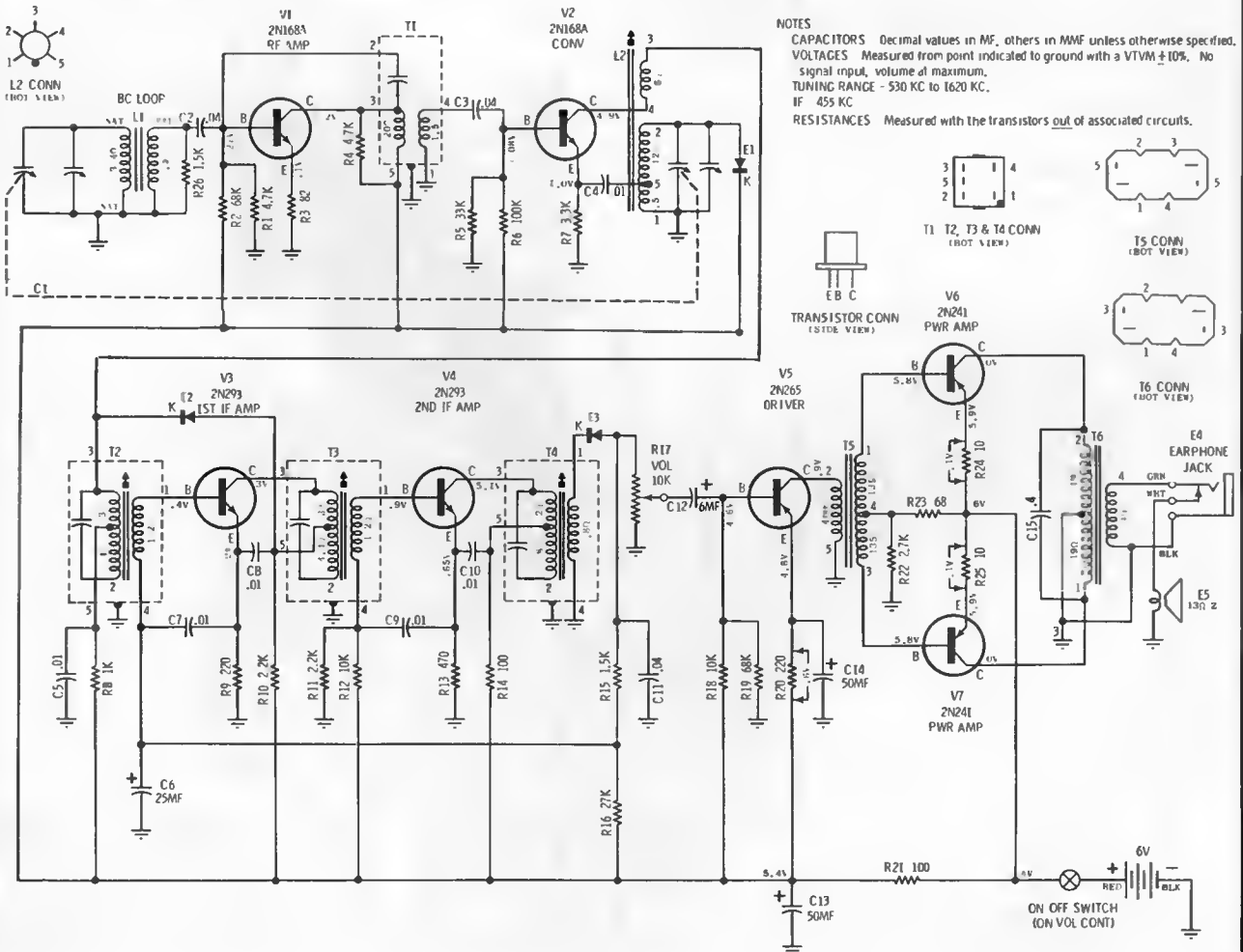

MOTOROLA

MODELS CHASSIS
 SF11B HS-703
 SF11N HS-703

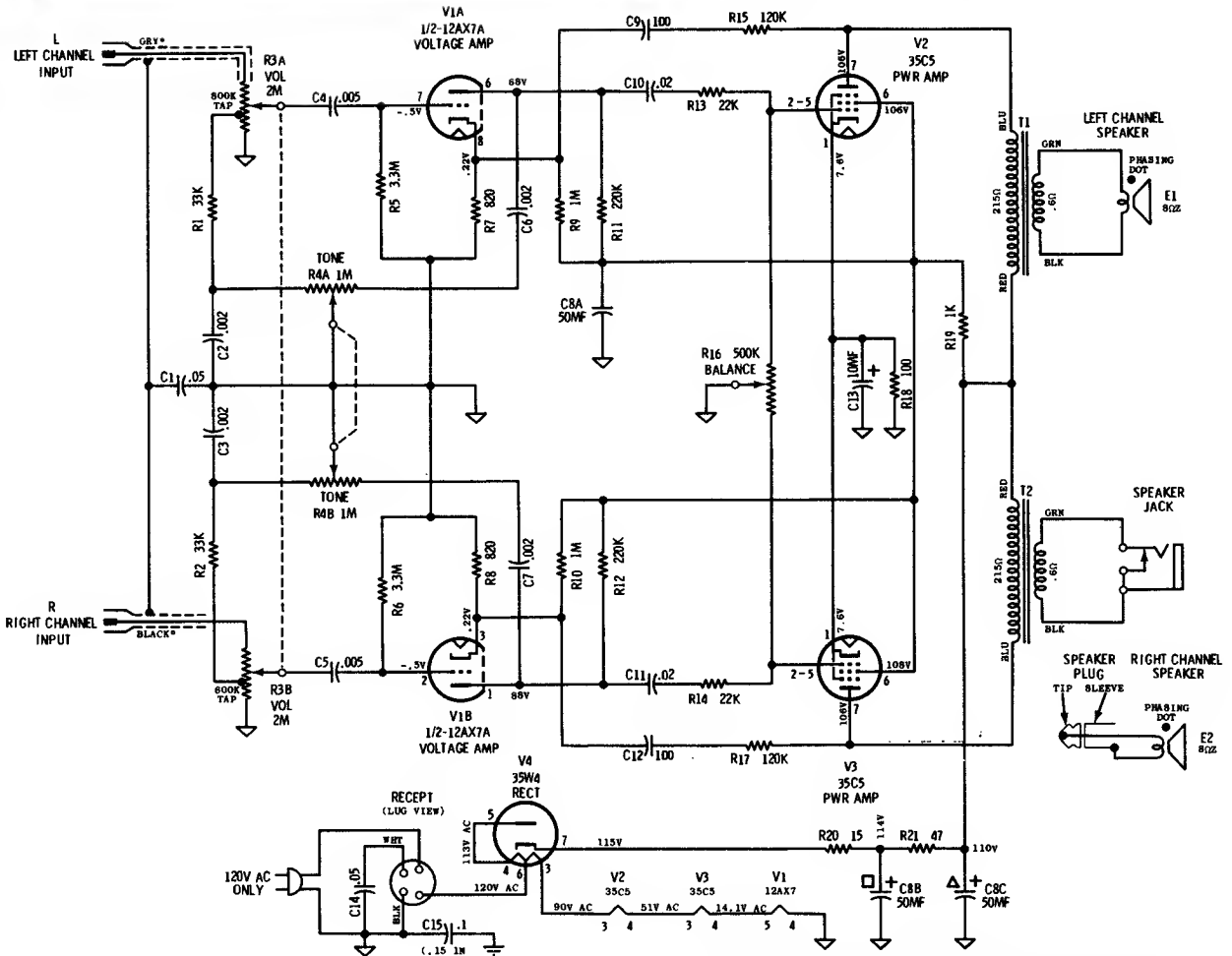

NOTES:
 CAPACITORS - Decimal values in MF, all others in MMF unless otherwise specified.
 VOLTAGES - Measured from point indicated to B- with a VTVM, $\pm 10\%$. No signal in.
 ∇ , B- ∇ Chassis ∇ Record changer frame
 *On some units, the phono input cable colors were reversed.

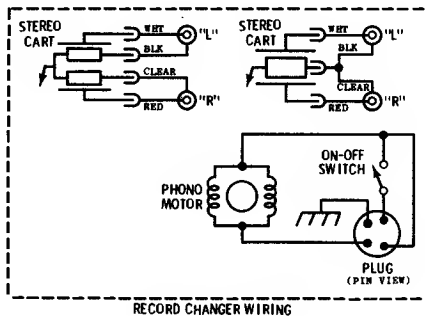

The chassis of this amplifier is isolated from the AC power line by a capacitor to eliminate the shock hazard when handling the chassis. However, as an additional precaution, when servicing this amplifier, an isolation transformer should be inserted between the power line and the chassis.

TO REMOVE CHASSIS FROM CABINET

1. Remove 3 control knobs.
2. Remove 3 baffle mounting screws and unscrew speaker jack mounted on baffle; then remove baffle.
3. Remove record changer mounting board screws.
4. Lift mounting board and record changer high enough to permit access to bottom of changer.
5. Unplug phono cables connected to record changer "R" and "L" jacks, also unplug phono power plug.
6. Remove 4 chassis mounting nuts.
7. Unsolder speaker leads.
8. Remove chassis from cabinet.

TO REMOVE RECORD CHANGER FROM CABINET

1. Remove 3 baffle mounting screws and unscrew speaker jack mounted on baffle; then remove baffle.
2. Remove record changer mounting board screws.
3. Lift mounting board and record changer high enough to permit access to bottom of changer.
4. Unplug phono cables connected to record changer "R" and "L" jacks, also unplug phono power plug.
5. Turn the two record changer mounting screws fully clockwise (down flush against changer base).
6. Place clips, located at ends of record changer mounting screws, so that they are parallel with the screws.
7. Remove record changer from cabinet.

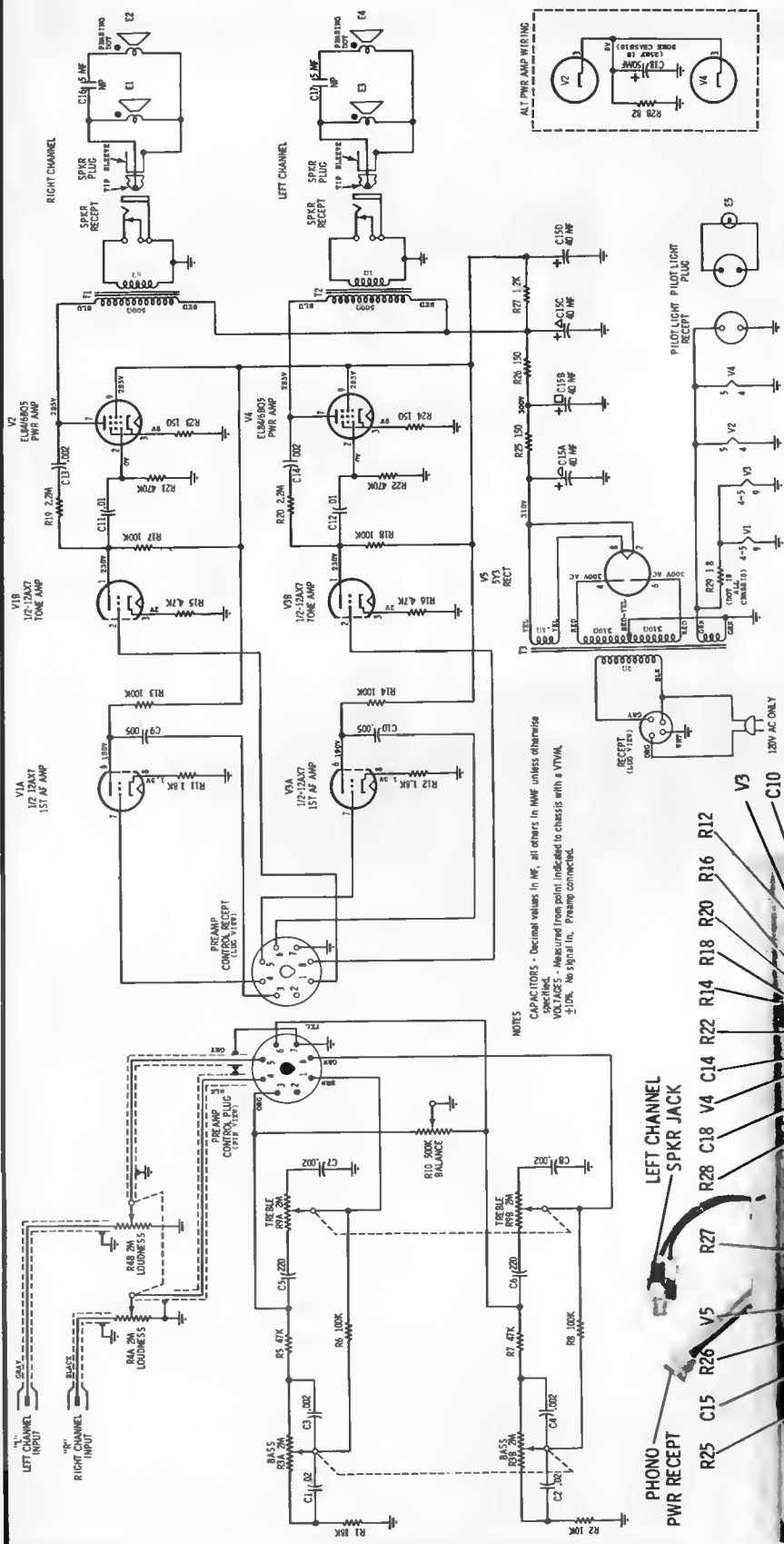

NOTES
 CAPACITORS - Decimal values in MF, all others in MMF unless otherwise indicated.
 VOLTAGES - Measured from point indicated to chassis with a VTVM.
 ±10%. No signal in. Preamp connected.



MODELS
 SH12E
 SH12N
 SH12S

CHASSIS
 HS-704
 HS-704
 HS-704

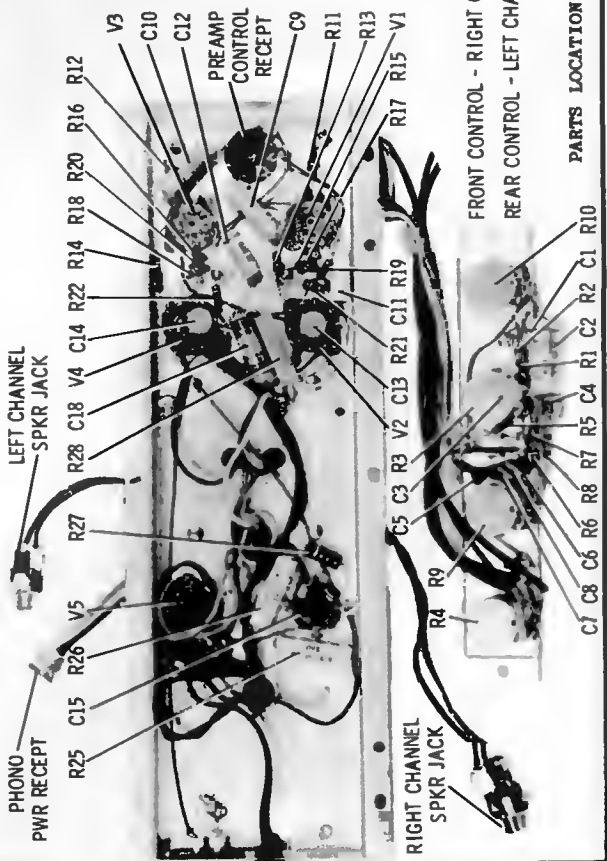
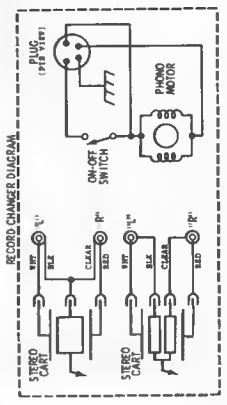

MOTOROLA

MODELS	CHASSIS
SK21B, M	HS-735
SK23B, CW, M	HS-735
S21B, CW, M	-

Models SK21 and SK23 are console stereophonic phonographs containing four-speed record changers with stereophonic cartridge and multiple speaker systems. These models differ from each other in type of record changer used and cabinet design. Model S21 is the right channel speaker system used with SK21 and SK23 to complete the stereophonic system.

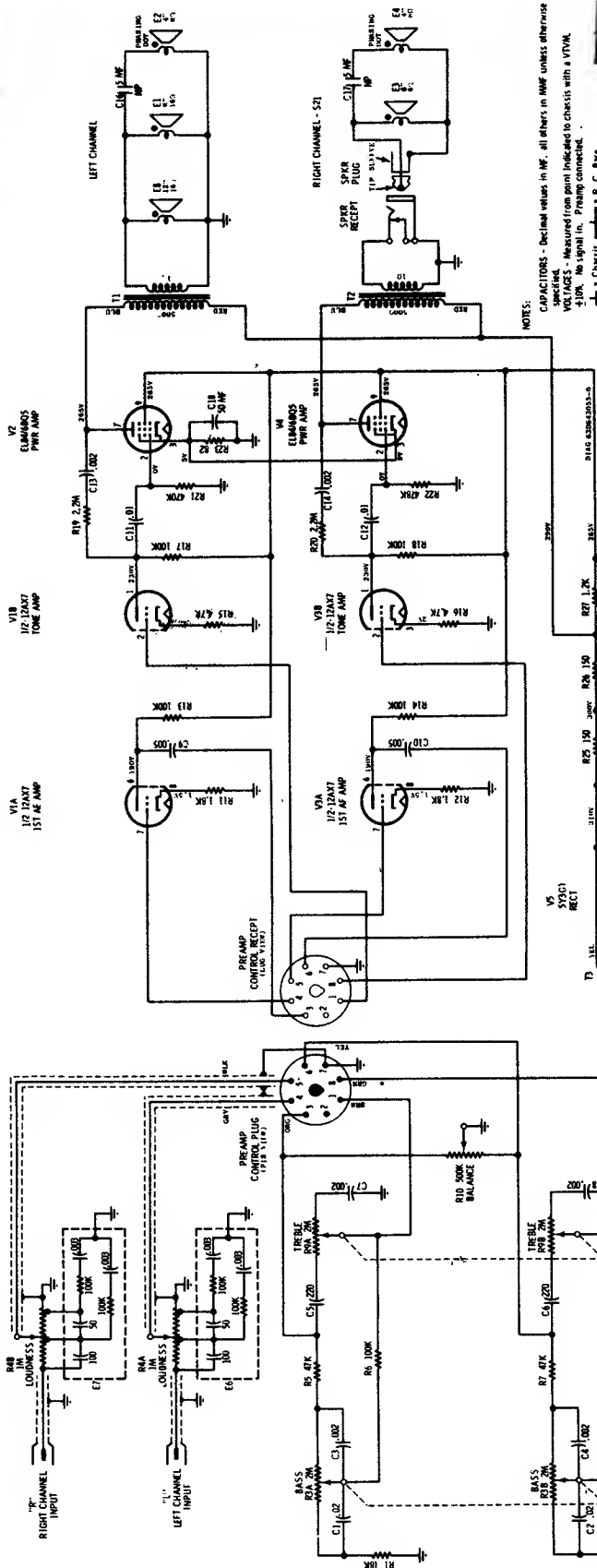

NOTES:
 CAPACITORS - Declined values in MF. All others in MMF unless otherwise specified. Measured from ground indicated to chassis with a VPK.
 *10K. No signal in. Preamp connected.
 † Chassis 7777 - P. C. Box

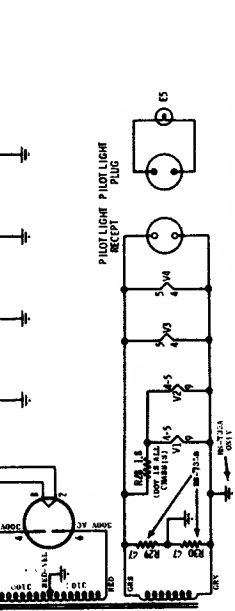

To Remove Record Changer from Cabinet (SK23 Series)

1. Remove back cover.
2. Disconnect all changer leads.
3. Turn two record changer mounting screws fully clockwise.
4. From bottom of changer, turn the two mounting clips located at mounting screw ends so they are parallel with the screws.
5. Grasp changer by base and lift up.

To Replace Pilot Light (All Models)

1. Remove cabinet rear cover.
2. From inside cabinet, unclip pilot light socket from mounting bracket.
3. Remove pilot light.

DISASSEMBLY INSTRUCTIONS

To Remove Chassis from Cabinet (All Models)

1. Pull off control knobs.
2. Remove cabinet back cover.
3. Disconnect all leads from changer and speakers.
4. Unplug pilot light at chassis.
5. Unplug control plug at chassis.
6. Remove nut from output jack and remove jack from mounting bracket.
7. Remove chassis mounting screw and slide chassis out rear of cabinet.
8. Remove 2 nuts from control unit mounting screws.
9. Remove control unit.

PACKARD BELL

TABLE MODEL RADIO 5R5

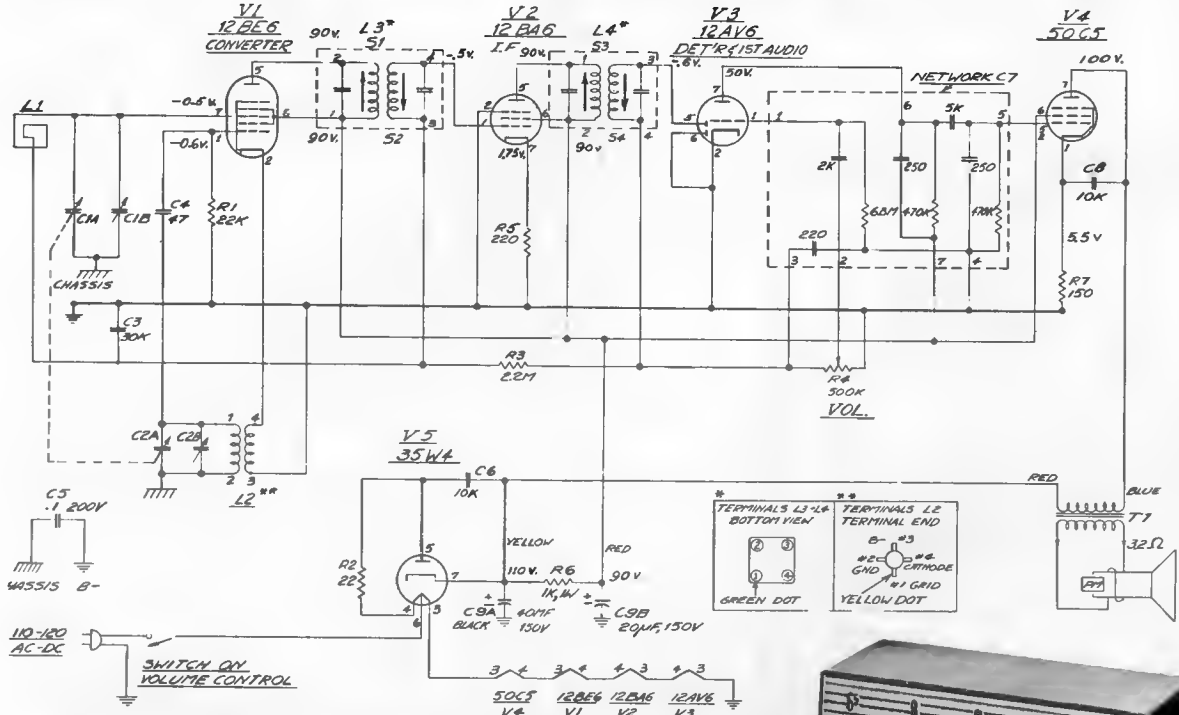

DC RESISTANCE MEASUREMENTS:

1st I-F Coil:

- Primary, 19 ohms
- Secondary, 19 ohms

2nd I-F Coil:

- Primary, 19 ohms
- Secondary, 19 ohms

Oscillator Coil:

- Primary, 1 ohm
- Secondary, 10 ohms

Socket voltages measured as follows:

1. Line voltage, 117 volts AC.
2. Volume control at maximum.
3. VTVM between socket terminal and B minus bus.
4. Only DC voltages measured. Allow 10% tolerance.

ALIGNMENT PROCEDURE:

The alignment of the set is accomplished by following the steps in the chart below. Connect output meter to speaker voice coil. Use isolation transformer, if available, for shock protection.

Each adjustment should be made using a minimum input signal. Connect oscillator through a .01 mfd capacitor in step one; loose-couple oscillator lead in steps two and three.

Step	Connect Test Oscillator To	Test Oscillator Frequency	Radio Dial Setting	Adjust
1.	Pin 1, V-1 (12BE6)	455 Kc.	540 Kc.	S-1, S-2, S-3, & S-4 for MAX.
2.	Loose-couple to antenna	1620 Kc.	1620 Kc.	C-2B for MAX.
3.	ditto	1500 Kc.	Tune to Osc. Signal	C-1B for Max.

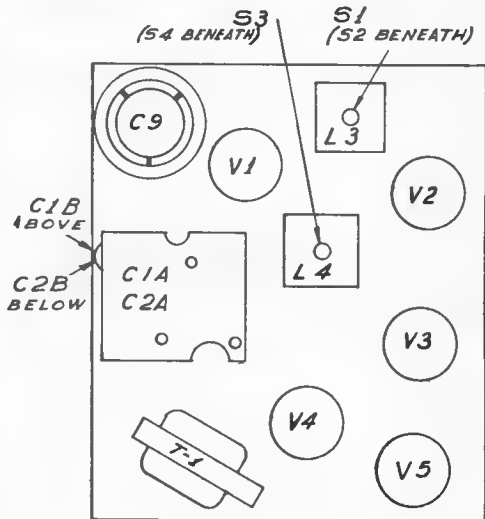

PACKARD BELL MODEL 6RT2 PERSONAL TRANSISTOR RADIO

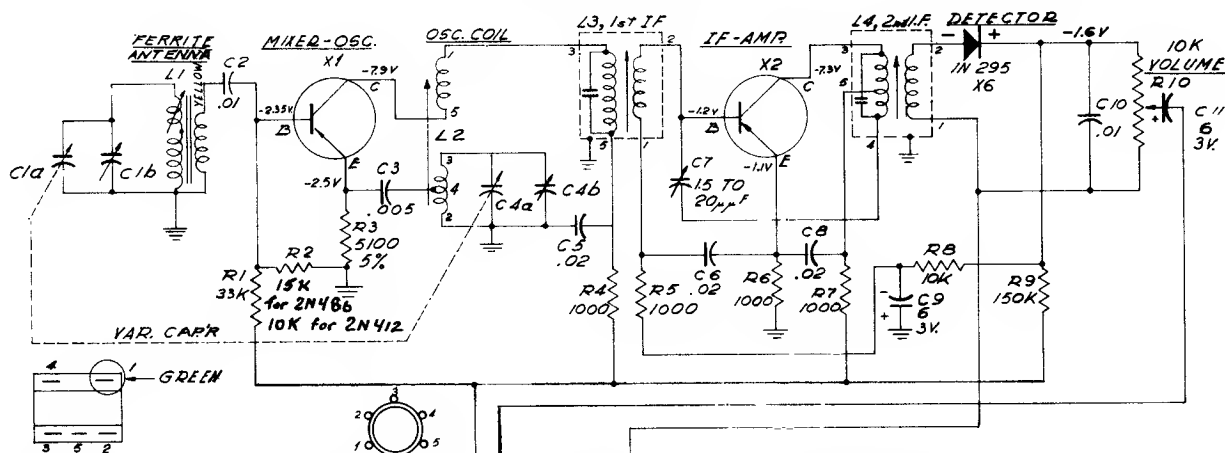

BOTTOM VIEW OF I-F AND OSCILLATOR COIL TERMINALS

- NOTE:**
1. ALL RESISTORS $\frac{1}{2}$ WATT $\pm 10\%$ UNLESS OTHERWISE NOTED
 2. K = 1000 OHMS
 3. ALL CAPACITORS IN MFD UNLESS OTHERWISE NOTED
 4. D.C. WORKING VOLTAGE IS 25V. UNLESS OTHERWISE NOTED
 5. D.C. VOLTAGES MEASURED WITH V.T.V.M. TO COMMON GROUND (POSITIVE) - NO SIGNAL - VOL. CONT. AT MAX.

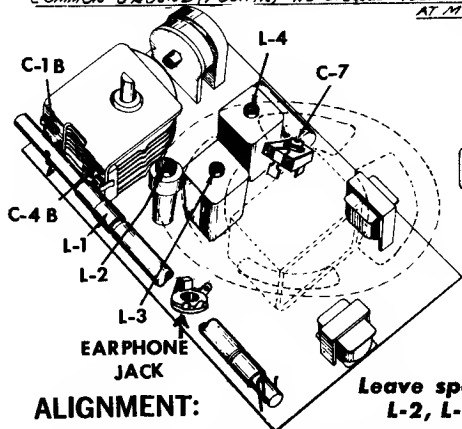

ALIGNMENT:

Leave speaker in place; adjust L-2, L-3, & L-4 from rear.

Step 1. Preset I-F amplifier neutralizer capacitor C-7 by turning completely clockwise (maximum

capacity) then back one eighth of a turn (45 degrees). See note after step seven.

ITEM	TRANSISTOR	RAYTHEON	R.C.A.
X1	MIXER-OSC.	2N486	2N412
X2	I-F AMR	2N483	2N410
X3	AUDIO AMP.	2N363	2N406
X4,5	AUDIO OUT. #	2N652	2N408
X6	DETECTOR DIODE	IN 295	

* MATCHED PAIR OR SAME GAIN GROUP NO.

Step	Connect Test Oscillator To	Test Oscillator Frequency	Radio Dial Setting	Adjust
2.	Variable, antenna section	455 kc	535 kc	L-3 & L-4 for MAX
3.	Couple to antenna	600 kc	600 kc	L-2 (osc) for MAX
4.	Couple to antenna	1620 kc	1E20 kc	C-4B for MAX
5.	Repeat steps two and three and check calibration at low end of dial (535 kc)			
6.	Couple to antenna	1500 kc	Tune to test osc. signal	C-1B for MAX
7.	Couple to antenna	600 kc	600 kc	L-1 (antenna) for MAX

NOTE: Optimum setting of neutralizing capacitor C-7 depends upon parameters X-2 and L-4. If, after alignment, regeneration occurs on stations near the high end of the dial, capacity of C-7 should be decreased (ccw). Too low a value, however, will result in loss of

sensitivity.

If it has been necessary to change the setting of C-7 more than 45 degrees after completing the alignment, then the I-F adjustment (step two) should be repeated.

PHILCO RADIO MODEL T-3 - CODES 132, 134, 136 & 138

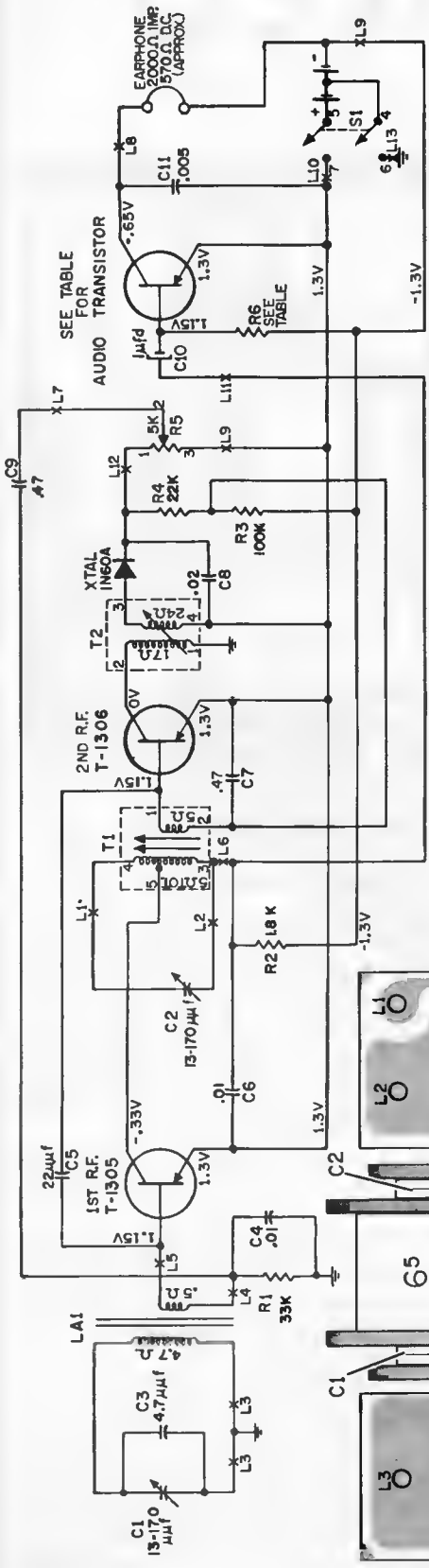

VOLTAGES MEASURED WITH A 20,000 OHM/VOLT METER TO GROUND, NO SIGNAL, VOL. CONTROL MAX. RESISTANCES MEASURED WITH COILS IN CIRCUIT.

138	T-0041	120K Ω
136	T-0040	220 K
134	T-0039	47D K
132	T-0038	1M
CODE	AUDIO TRANSISTOR	BASE RESISTOR RB

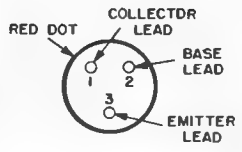

AUDIO TRANSISTOR - CODE VARIATIONS

The only differences between the four codes are the audio transistor type and the value of the audio base resistor. These value differences are indicated in the chart above.

PANEL-WIRE TERMINAL IDENTIFICATION

- L1 Orange lead from r-f tuning, C2, to T1 lug 4.
- L2 Black lead from r-f tuning, C2, to T1 lug 3 and red jumper to terminal 6.
- L3 Orange lead from ant. tuning, C1, and plain lead from bottom of ant. pri. (LA1) to panel ground.
- L4 Red lead from bottom of ant. sec. (LA1) to junction of R1, C4 and C5.
- L5 Red lead from top of ant. sec. (LA1) to 1st r-f base.
- L6 Red jumper from terminal 2, black jumper to terminal 11 and junction of C6 and R2.
- L7 Yellow lead to arm of volume control (R5).
- L8 Earphone lead to audio collector.
- L9 Black lead from battery, -1.3 volts.
- L10 Red lead from switch S1 lug 7, +1.3 volts.
- L11 Black jumper from terminal 6 to C10, the lufid audio coupling.
- L12 Orange lead to top of volume control, R5 lug, 1.
- L13 Black lead from switch, S1, lug 6 to panel ground.

SHIELDING

To suppress possible regeneration, the leads of T1 are shielded by wrapping a small piece of aluminum tape around the can so as to cover the cut-outs. When replacing be careful not to cause shorts.

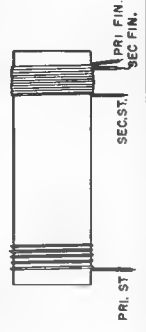

Composite Panel View, Foil Side Showing Parts Placement.

PHILCO

MODELS T-4 and T-4J - CODE 124

ALIGNMENT CHART

STEP	SIGNAL GENERATOR		RADIO		ADJUST
	CONNECTION TO RADIO	DIAL SETTING	DIAL SETTING	SPECIAL INSTRUCTIONS	
1	Panel must be removed from cabinet. Connect signal generator through a .1 uf condenser to antenna section of gang. Use the least generator signal necessary to give an output indication.	455 KC	Tuning gang fully open.	Adjust for maximum output in order given.	Z3—3rd IF Z2—2nd IF Z1—1st IF
2	Use radiating loop (See note 1 below).	1620 KC	1620 KC (gang fully open)	Pre-set C2A (Ant.) 1/2 turn from tight. Adjust for maximum output.	C1B—osc. trimmer
3	Same as step 2.	1400 KC	1400 KC	Adjust for maximum output.	C1A—ant. trimmer
4	Same as step 2. Panel MUST be re-mounted in cabinet.	600 KC	600 KC	Adjust for maximum output. Rock tuning gang while making this adjustment.	T1—osc. core
5	Repeat steps 2, 3 and 4 until no further improvement is obtained. Always stop on step 2.				

NOTE 1. Use a 6-to-8 turn, 6-inch diameter loop made up of insulated wire. Connect to generator terminals, and place about one foot from radio loop.

SCHEMATIC NOTES

Due to 2nd IF transistor variations the values of resistors R6 and R7 must be selected, within limits, for optimum performance.

When transistor R186 is defective, kit number 324-8003 must be ordered. This kit contains a R186 transistor and two resistors (R6 and R7) properly matched. All three components must be replaced.

The stage may be checked as follows:

The value of R6 is selected to allow the 2nd IF transistor collector to draw 2 milliamps. This is checked by measuring the voltage across R11, the 560 ohm collector return resistor. This voltage should be 1.12 volts, with a tolerance of approximately ± 12 volts. The value of R6 falls within the limits of 27K to 390K.

All resistors are 1/2 watt, 10%, carbon.

Coil resistances read with coil in circuit.

Voice coil impedance = 14 ohms.

Voltages measured to ground with a 20,000 ohms/volt meter under no signal condition.

Emitter to base voltages were measured with positive lead to emitter, except for the 1st IF which is an NPN type and measured with the positive lead to the base.

Run #51 — to improve low end sensitivity. The value of R1 was changed to 15,000 ohms, part number 66-3158340. Some few sets may have a 10,000 ohm resistor for R1.

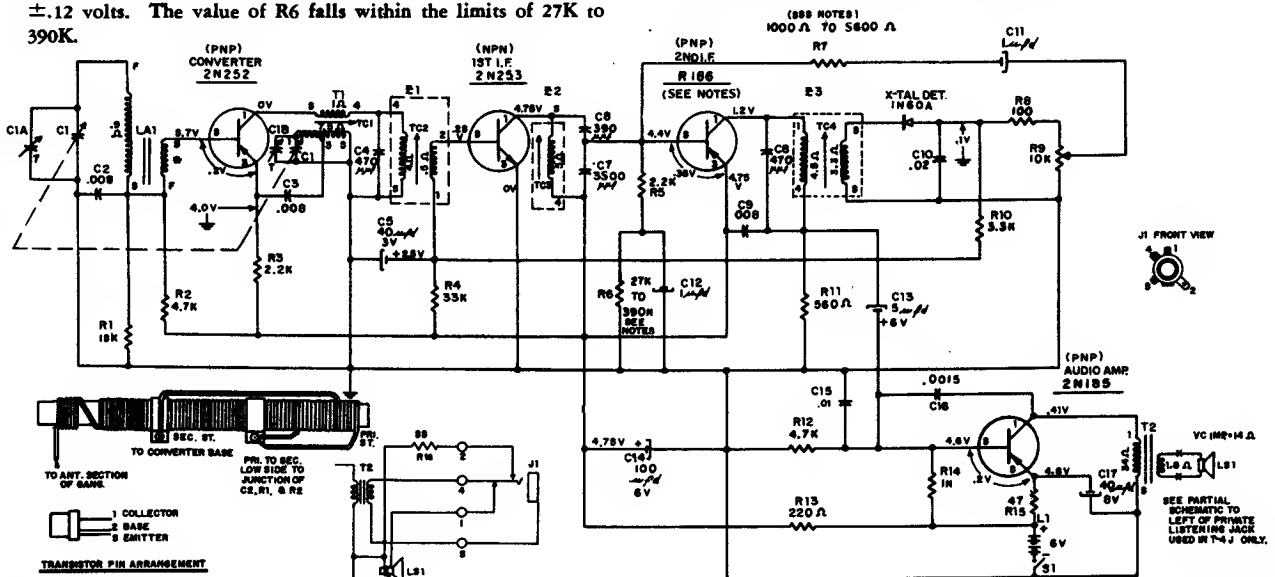

PHILCO

PHILCO TRANSISTOR RADIO MODEL T-5 - CODE 124

Schematic Diagram of Model T-5 - Code 124

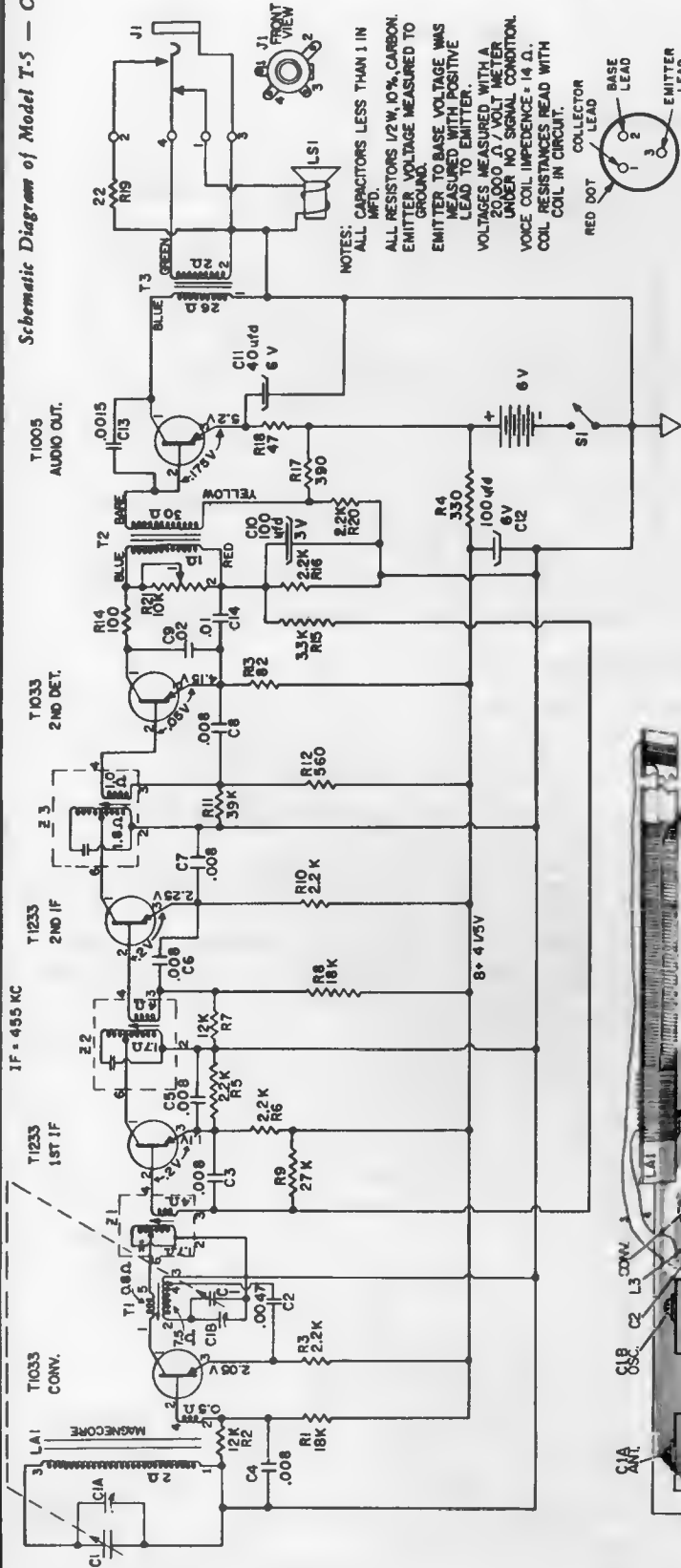

NOTES:
 CAPACITORS LESS THAN 1 IN ALL MFD.
 ALL RESISTORS 1/2 W, 10% CARBON. EMITTER VOLTAGE MEASURED TO GROUND.
 EMITTER TO BASE VOLTAGE WAS MEASURED WITH POSITIVE LEAD TO EMITTER.
 VOLTAGES MEASURED WITH A 20,000 Ω / VOLT METER UNDER NO SIGNAL CONDITION.
 VOICE COIL IMPEDENCE = 14 Ω.
 COIL RESISTANCES READ WITH COIL IN CIRCUIT.



TERMINAL LUG IDENTIFICATION

- L1 Orange jumper to L4, 5 volt B+.
- L2 Yellow lead to T2.
- L3 To short antenna lead no. 4.
- L4 Orange jumper to L1, 4.5 volt B+.
- L5 Black jumper to ground lug L10.
- L6 Black lead to positive battery terminal (6 volts).
- L7 Green lead to arm of R21.
- L8 Green lead to end (No. 2) of R21.
- L9 Blue lead of T3.
- L10 Ground lug: black lead to speaker, black lead to L5 and black lead to on-off switch.

PRIVATE LISTENING JACK TERMINAL LEADS

- Terminal 1—Brown lead to speaker.
 - Terminal 2—One end of R19, P.I. shunt resistor.
 - Terminal 3—Black ground lead to on-off switch and other end of R19.
 - Terminal 4—Green lead of T3.
- NOTE: C14 wires under the panel, from L8 to the junction of C9 and the emitter (No. 3) of the 2nd detector.

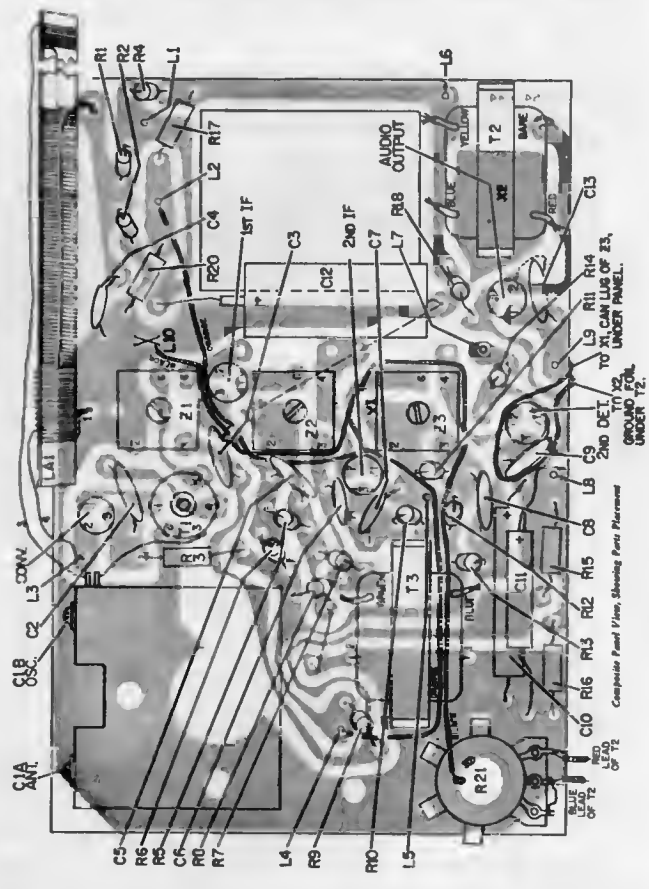

PHILCO PORTABLE RADIO TRANSISTOR MODEL T-60, CODE 124

T-1008
MATCHED PAIR
AUDIO OUTPUT

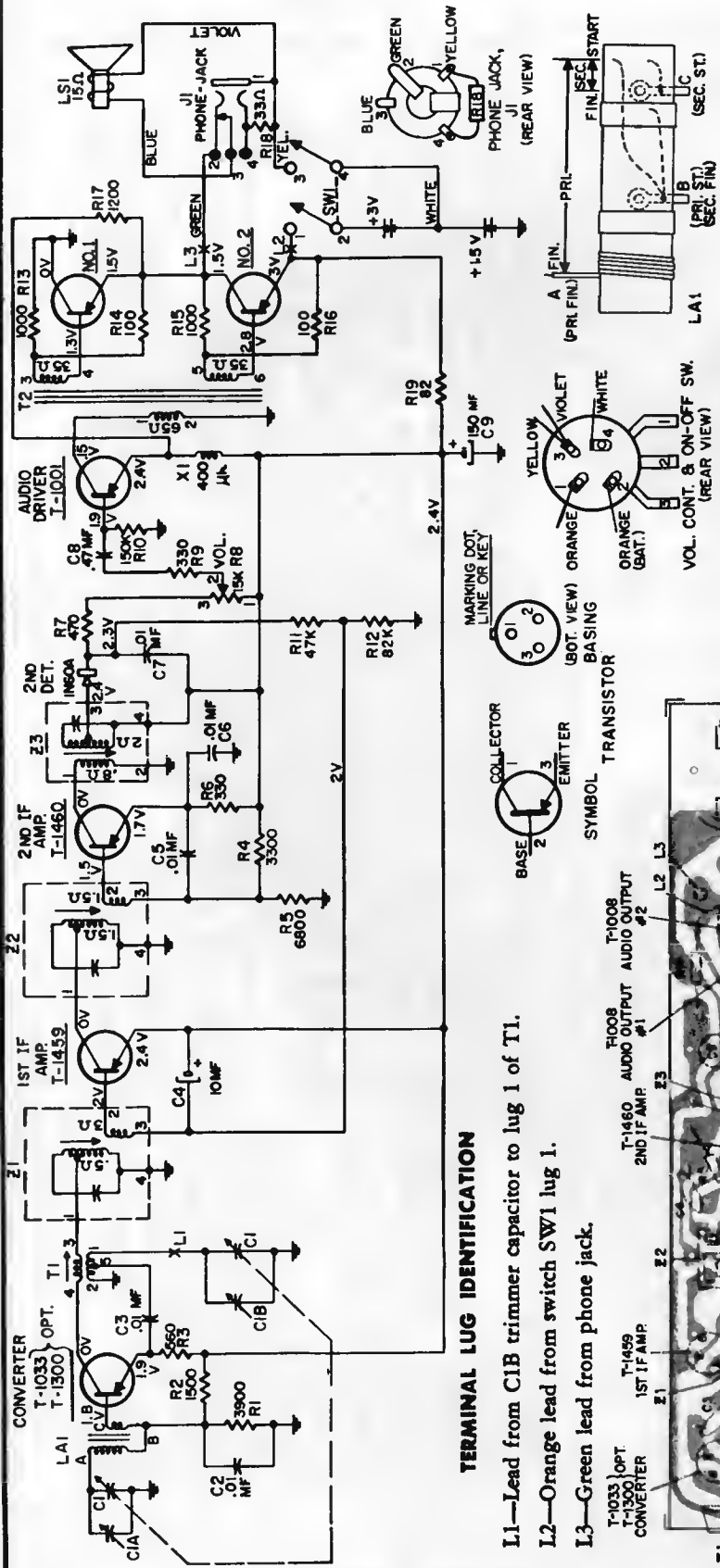

FREQUENCY COVERAGE—535 to 1620 KC.
INTERMEDIATE FREQUENCY—455 KC.
ANTENNA—Self-contained magnacor, high-impedance loop.
SPEAKER—2 3/4 in. pm., 15 ohm voice coil impedance. Jack provided for optional private listening attachment, part number 42-1975-4.

PRINTED-WIRE PANEL REMOVAL

1. Remove the snap-on back of the cabinet and the batteries.
2. Remove the trim-mount fastener next to the battery clips.
3. Carefully spread the sides of the cabinet to free the panel from each of the 4 slotted cabinet supports.
4. Withdraw the panel assembly by sliding it toward the speaker end of the cabinet to free the tuning knob.

TERMINAL LUG IDENTIFICATION

- L1—Lead from C1B trimmer capacitor to lug 1 of T1.
- L2—Orange lead from switch SW1 lug 1.
- L3—Green lead from phone jack.

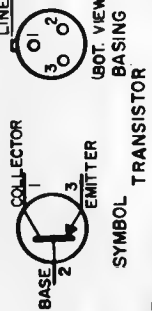

SYMBOL TRANSISTOR

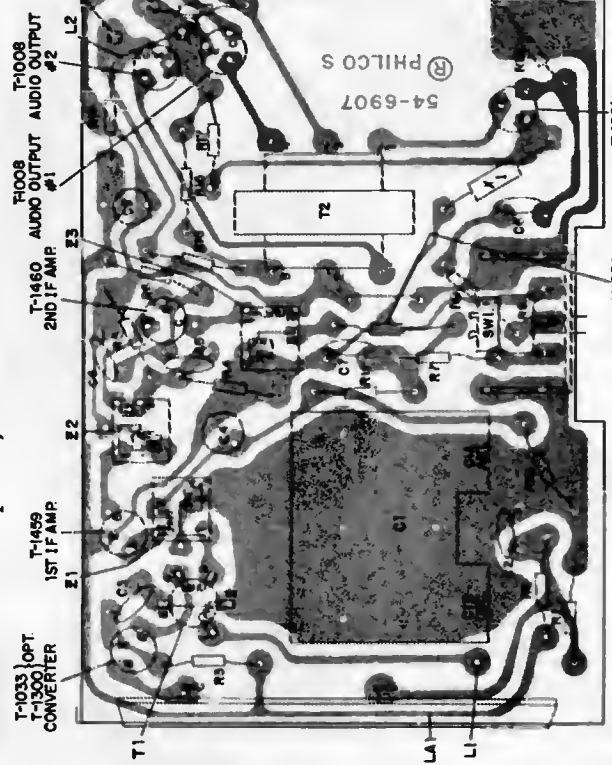

Component Panel Bottom View—Showing Parts Location

PHILCO TRANSISTOR RADIO — MODEL T-65

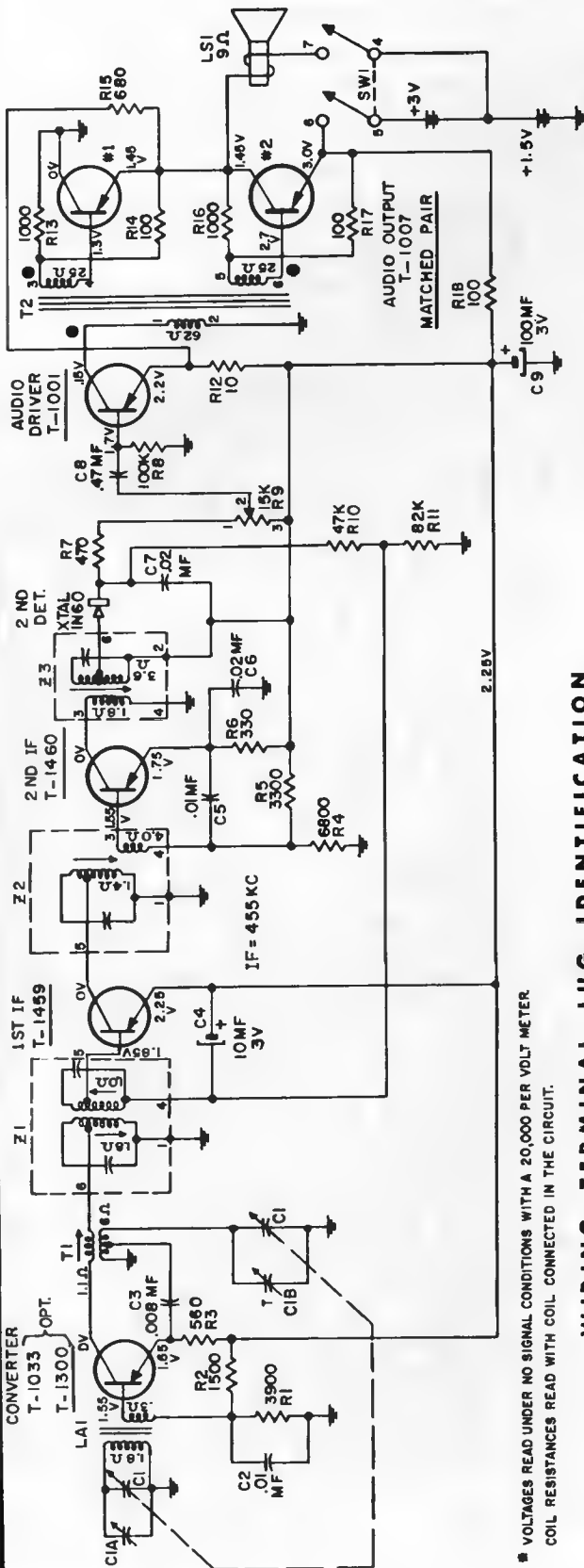

■ VOLTAGES READ UNDER NO SIGNAL CONDITIONS WITH A 20,000 PER VOLT METER.
 □ COIL RESISTANCES READ WITH COIL CONNECTED IN THE CIRCUIT.

WIRING TERMINAL LUG IDENTIFICATION

- L1 Black lead, battery ground.
- L2 Orange lead, 1.5V battery.
- L3 Red lead, 3.0V battery.
- L4 Green lead, audio output to speaker.
- L5 Red antenna lead, low side of secondary, lead #3.
- L6 Red antenna lead, high side of secondary, lead #4.
- L7 Antenna lead, high side of primary to ant. section of gang, lead #1.
- L8 Antenna lead, low side of primary to gang ground lug, lead #2.
- L9 Orange lead from speaker to terminal #7 of S1.

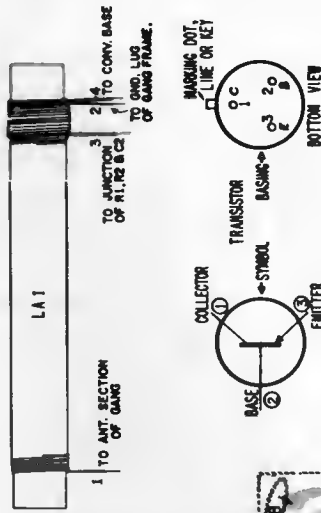

AUDIO OUTPUT—0.1 watt.

BATTERY VOLTAGE AND TYPE—3.0 volts from 2 standard "D" cells.

FREQUENCY COVERAGE—535 - 1620 KC.

INTERMEDIATE FREQUENCY—455 KC.

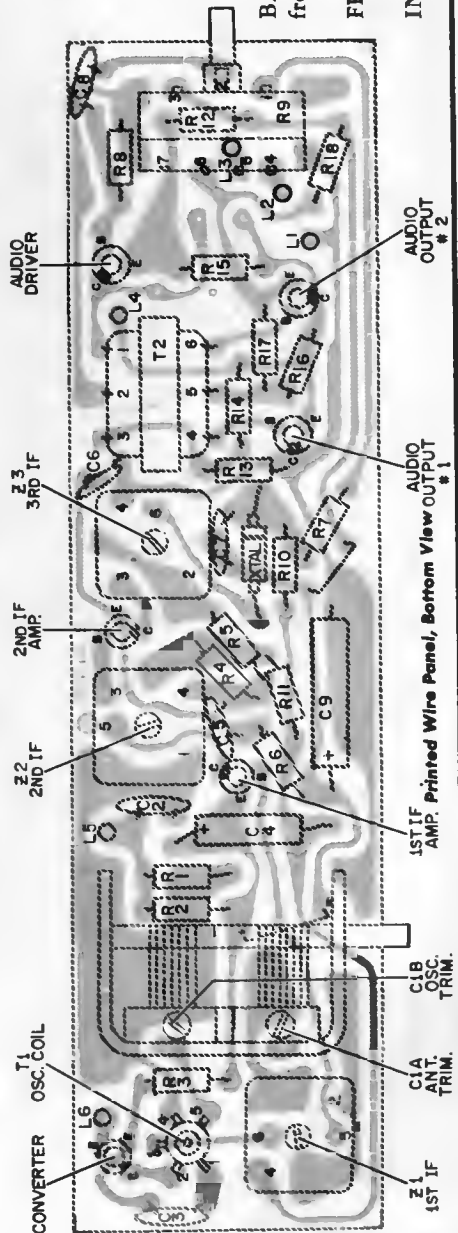

PHILCO PORTABLE RADIO MODEL T-75, CODE 124

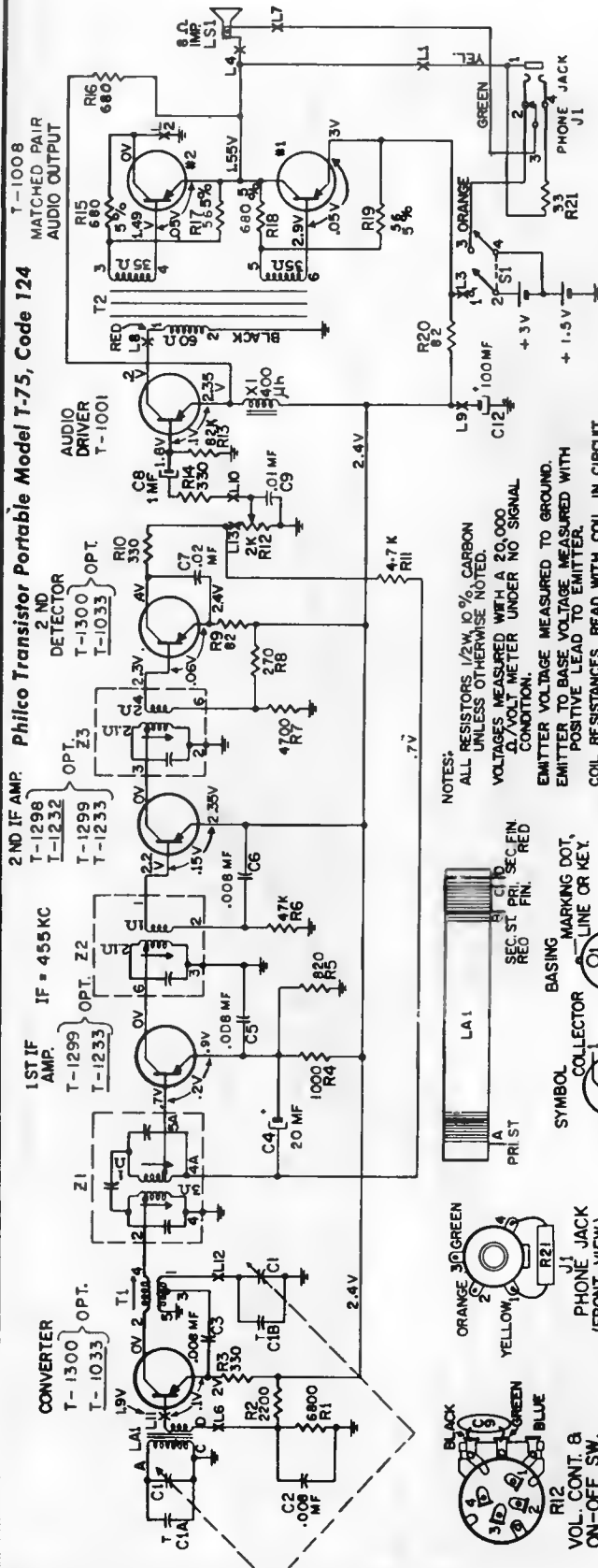

FREQUENCY COVERAGE—535 to 1620 KC.

INTERMEDIATE FREQUENCY—455 KC.

BATTERY SUPPLY—2 standard "D" cells, in 3 volt supply center tapped at 1-1/2 volts. Battery type P-907 or P-920 (metal clad).

SERVICE NOTES

When signal tracing, inject signal at transistor collector and limit input to keep signal across speaker below .6 volts.

Normally, the transistors should be the last item suspected.

If C12 opens serious audio oscillation will result.

Dress of black lead from top, center, frame lug of gang to end ground lug is important to reduce beat. See base layout for lead dress.

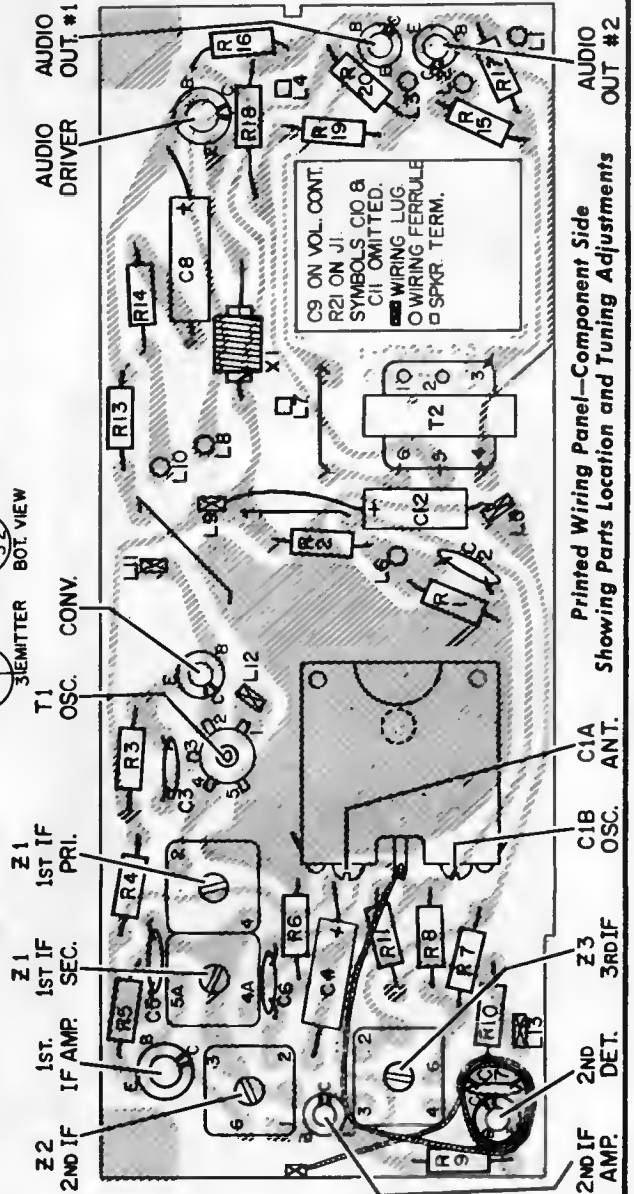
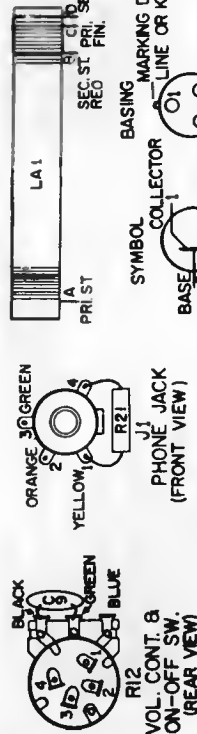

PHILCO RADIO

AM/FM TUNER — TYPE RT-202

Electrically all chassis are identical except the RT-202-2 and the RT-202-4. The RT-202-4 chassis contains a 560 ohm resistor and .01 mfd capacitor from the cathode of the AM-RF amplifier (V7) to ground. Lug L1 on the printed wire panel of the RT-202-4 chassis is grounded, thus returning the secondary of T10 and condenser C43 to ground instead of the AVC circuit. The RT-202-2 chassis uses an AM antenna coil while the remaining chassis use a magnecore antenna.

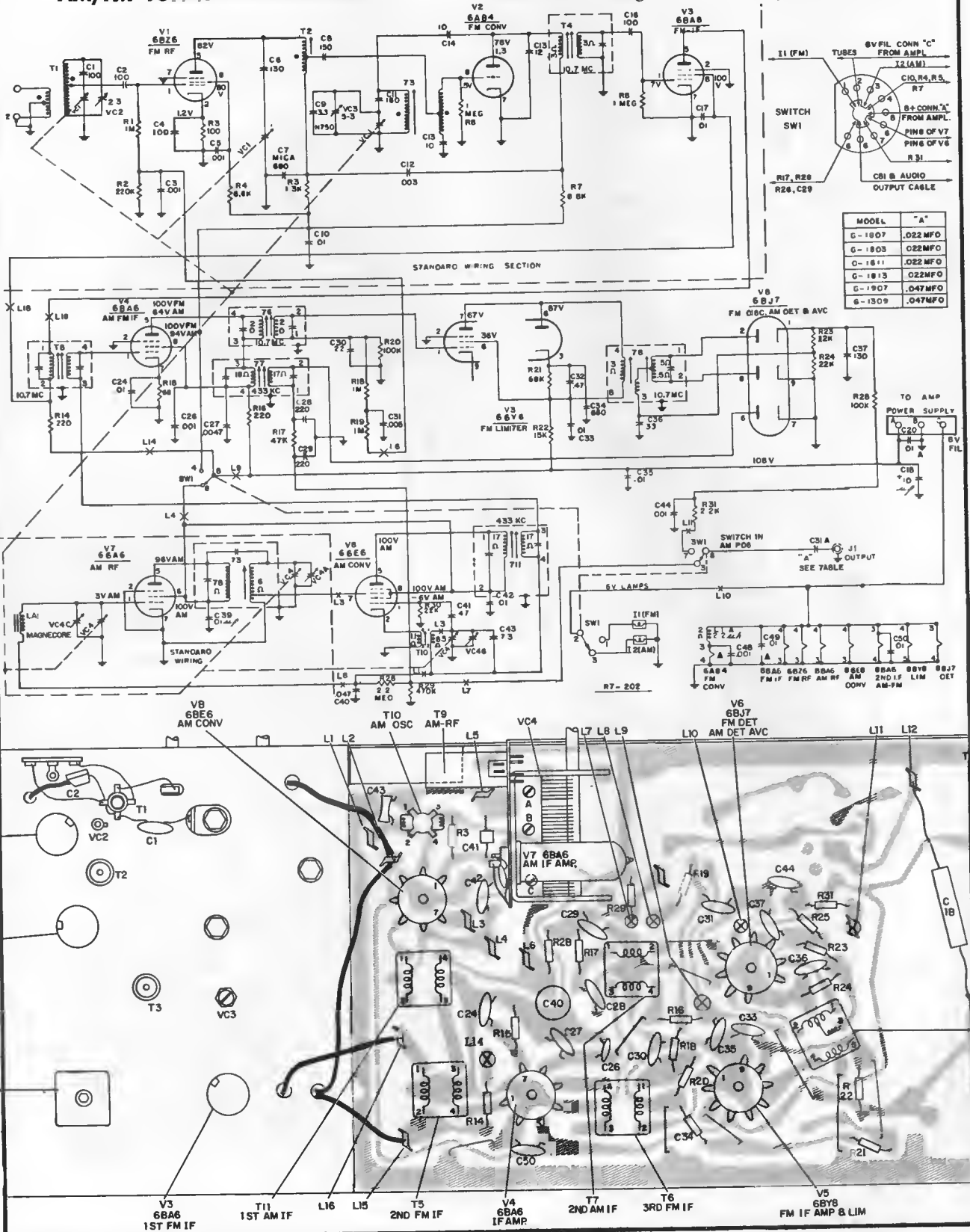

Top View — Showing Alignment Points, Tube Locations and Tie Lugs

PHILCO PORTABLE RADIO MODEL G-681, CODE 124

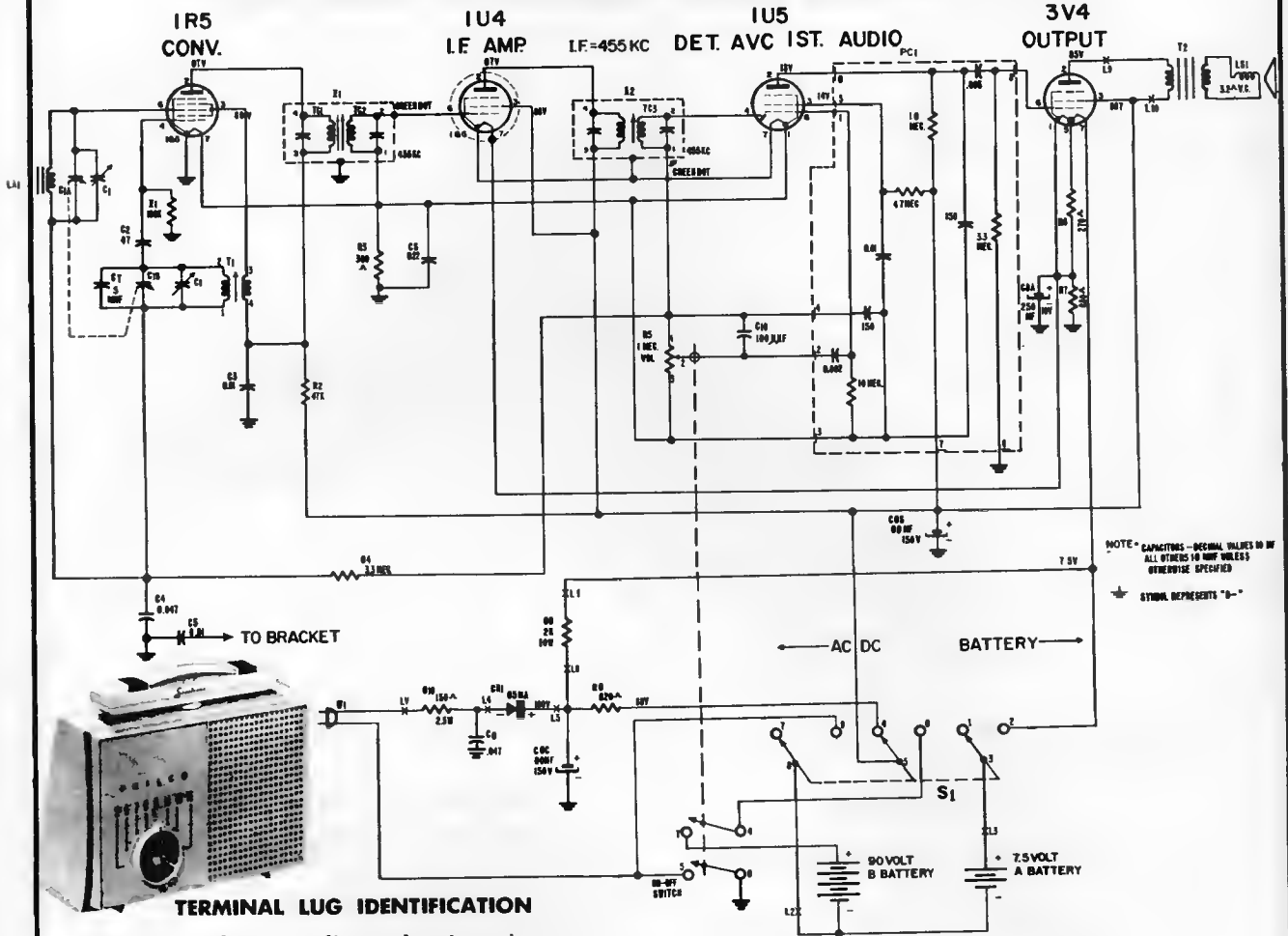

NOTE - CAPACITORS - DECIMAL VALUES IN μ F
ALL OTHERS IN PPF UNLESS OTHERWISE SPECIFIED
* SYMBOL REPRESENTS "B"

TERMINAL LUG IDENTIFICATION

- L1 Black lead from R9, filament dropping resistor.
- L2 B-, black lead from "A" battery and yellow lead from "B" battery.
- L3 A+, brown lead from "A" battery.
- L4 Black lead to selenium rectifier, CR1.
- L5 B+, red lead from CR1.
- L6 Brown lead to filament dropping resistor, R9.
- L7 White lead from AC interlock to R10.
- L8 Blue lead to L11, ground.
- L9 Blue lead from 3V4 plate to output trans., T2.
- L10 Red lead to output transformer, T2.
- L11 Blue lead to L8, ground.
White lead from AC interlock to lug 5 of ON-OFF switch.
Red lead from "B" battery to lug 7 of ON-OFF switch.

CR1 & R9 MOUNTED ON END BRACKETS.
T2 MOUNTED ON SPEAKER.
LA1 MOUNTED IN "SCAN-TENNA" HANDLE.

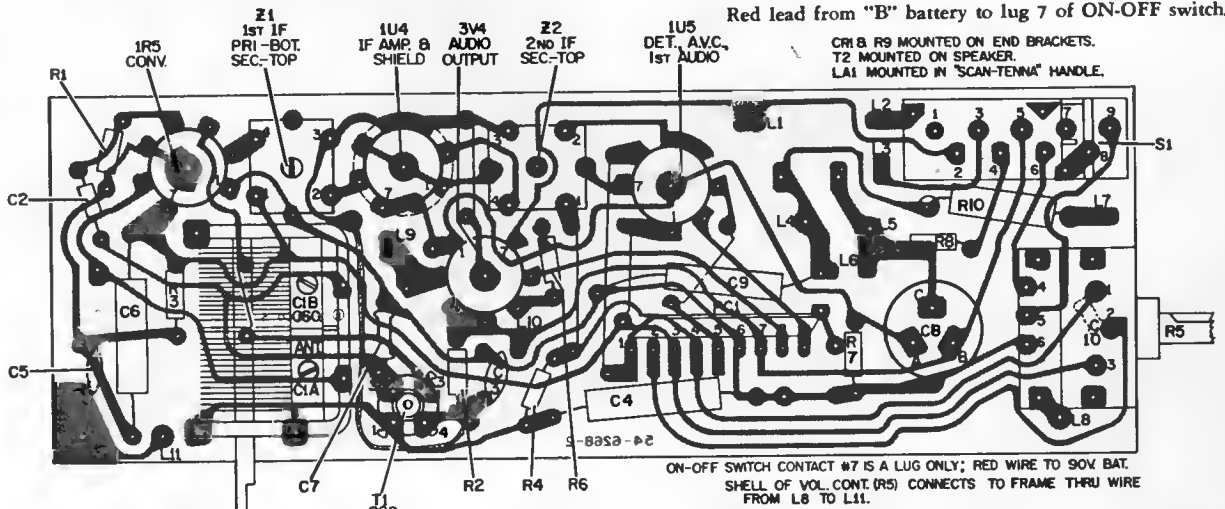

ON-OFF SWITCH CONTACT #7 IS A LUG ONLY; RED WIRE TO 90V. BAT.
SHELL OF VOL. CONT. (R5) CONNECTS TO FRAME THRU WIRE FROM L8 TO L11.

Composite Panel View, Showing Parts Placement

PHILCO PORTABLE RADIO MODEL H-691, CODE 124

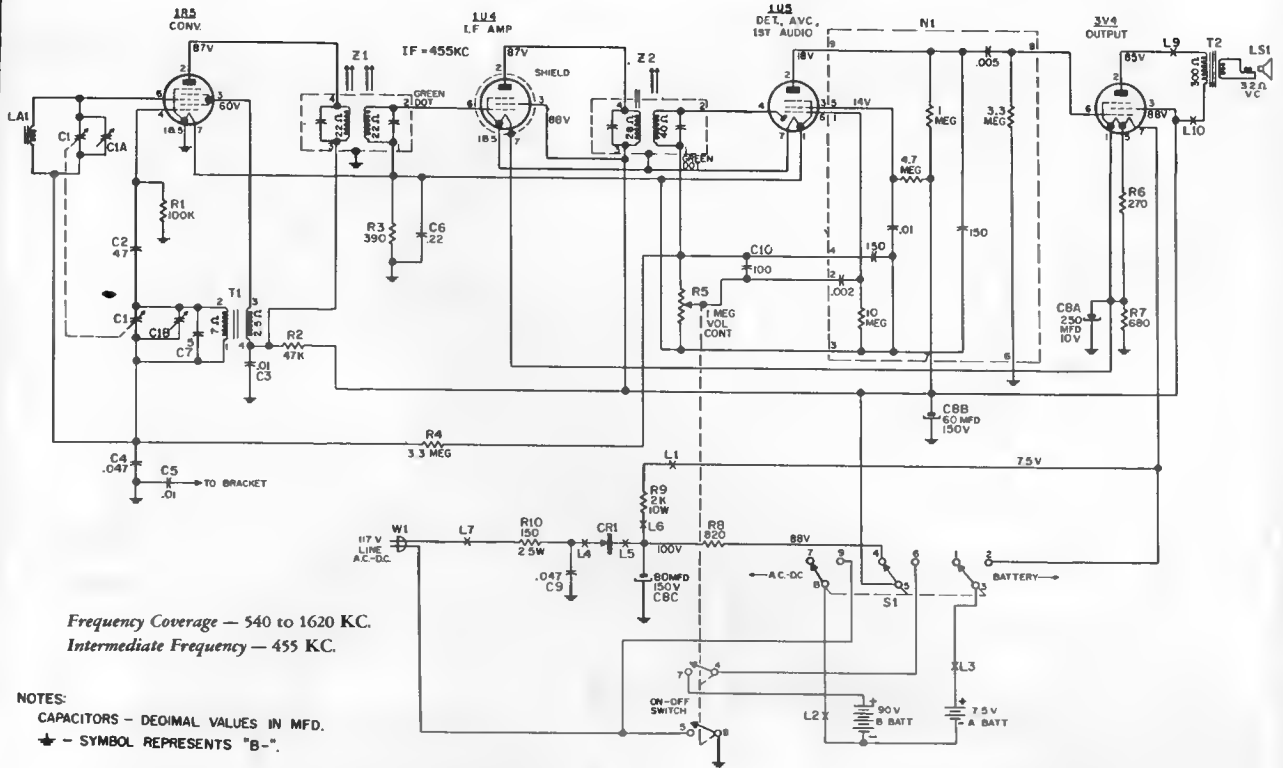

Frequency Coverage — 540 to 1620 KC.
Intermediate Frequency — 455 KC.

NOTES:
CAPACITORS — DECIMAL VALUES IN MFD.
★ — SYMBOL REPRESENTS "B-".

CRITICAL LEAD DRESS

1. Brown and black wires, from wiring panel on bracket, must be dressed below and away from R9 and in front of the tuning condenser, C1.
2. Brown and black "A" battery leads must be dressed over the output transformer, T2, and through the dress lug.
3. Red and yellow "B" battery leads must be dressed up through the AC interlock mounting bosses.
4. White AC interlock leads must be dressed toward the front panel.
5. All wires must be dressed clear of the current limiting resistor, R10.
6. C6, the filament gang, must be dressed toward the bracket, away from C1, the tuning gang.

TERMINAL LUG IDENTIFICATION

- L1 Black lead from R9, filament dropping resistor.
- L2 B-, black lead from "A" battery and yellow lead from "B" battery.
- L3 A+, brown lead from "A" battery.
- L4 Black lead to selenium rectifier, CR1.
- L5 B+, red lead from CR1.
- L6 Brown lead to filament dropping resistor, R9.
- L7 White lead from AC interlock to R10.
- L8 Blue lead to L11, ground.
- L9 Blue lead from 3V4 plate to output trans., T2.
- L10 Red lead to output transformer, T2.
- L11 Blue lead to L8, ground.
White lead from AC interlock to lug 5 of ON-OFF switch.
Red lead from "B" battery to lug 7 of ON-OFF switch.

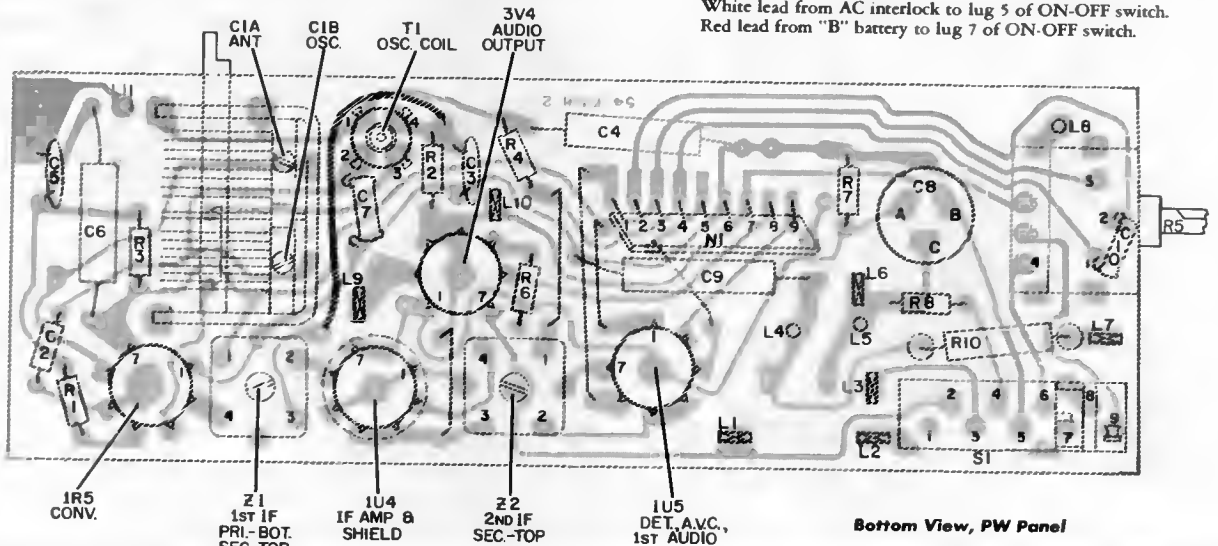

Bottom View, PW Panel

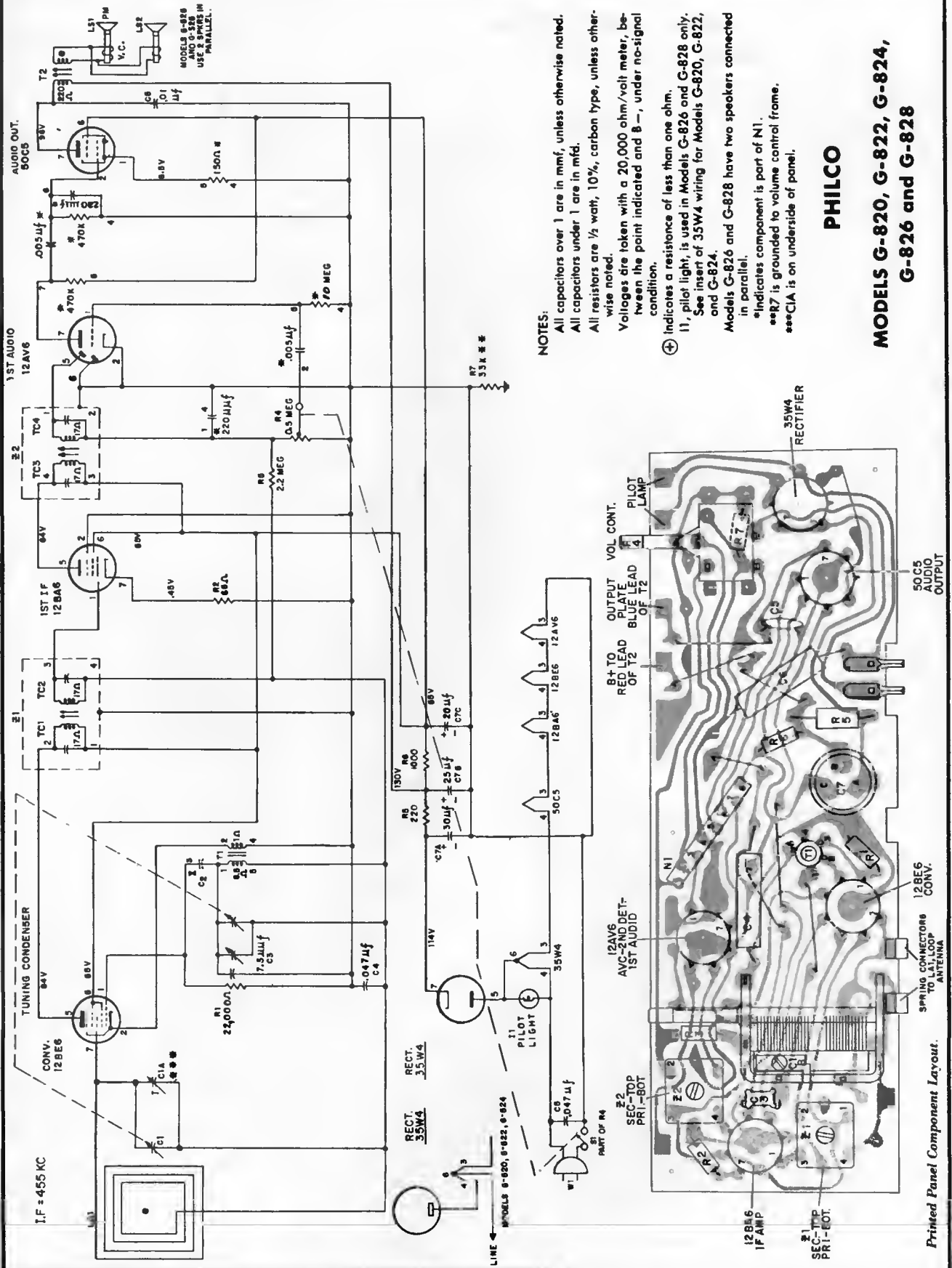

NOTES:

All capacitors over 1 are in mmf, unless otherwise noted.
 All capacitors under 1 are in mfd.

All resistors are 1/2 watt, 10%, carbon type, unless otherwise noted.

Voltages are taken with a 20,000 ohm/volt meter, between the point indicated and B-, under no-signal condition.

⊕ indicates a resistance of less than one ohm.

11, pilot light, is used in Models G-826 and G-828 only. See insert of 35W4 wiring for Models G-820, G-822, and G-824.

Models G-826 and G-828 have two speakers connected in parallel.

* indicates component is part of NI.

**R7 is grounded to volume control frame.

***CIA is on underside of panel.

PHILCO AM/FM MODEL G-974

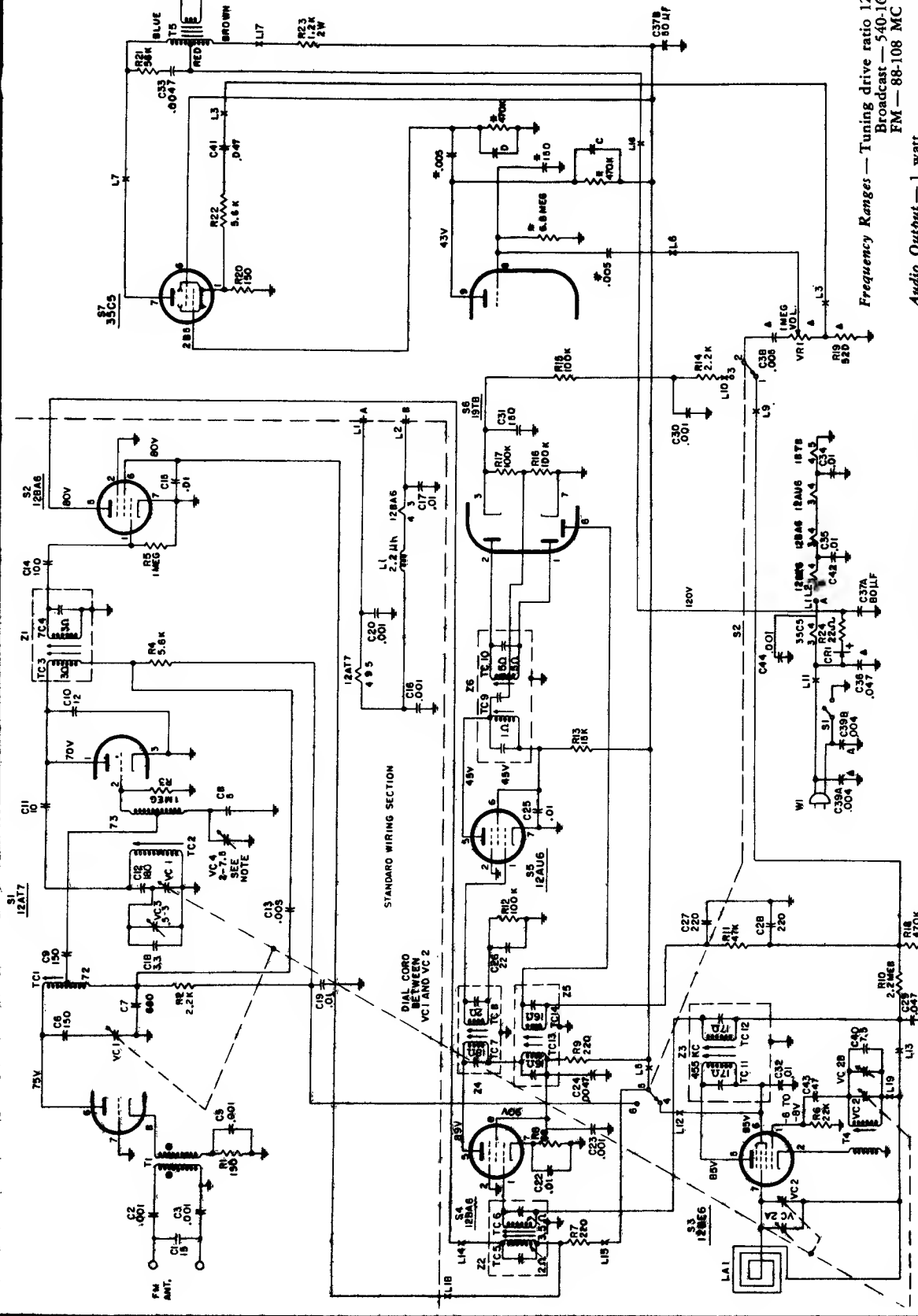

Frequency Ranges — Tuning drive ratio 12:1
 Broadcast — 540-1620 KC
 FM — 88-108 MC

Audio Output — 1 watt

Operating Voltage — 105 - 120 volts, a.c./d.c.

Power Consumption — 40 watts

Intermediate Frequency — AM 455 KC
 FM 10.7 MC

VC4 IS A FACTORY ADJUSTMENT AND SHOULD NOT REQUIRE FUTURE ADJUSTMENT UNLESS REPLACED. IT MINIMIZES OSCILLATOR RADIATION. TO ADJUST, TUNE RATIO TO 100 MC AND ADJUST VC4 FOR MINIMUM INDICATION ON A FIELD STRENGTH METER TUNED TO THE OSC FREQ.

ALL RESISTORS ARE 1/2 WATT, 10% UNLESS OTHERWISE NOTED.

ALL CAPACITORS ABOVE 1 ARE IN μ F UNLESS OTHERWISE NOTED, ALL CAPACITORS BELOW 1 ARE μ F.

* COUPLATE NI

▲ PART OF STANDARD WIRING

● INDICATES LESS THAN 1 OHM

CONDENSERS C - D - 250 μ F

PHILCO PHONOGRAPH MODEL G-1410

SPECIFICATIONS

- AUDIO OUTPUT—1.0 watt each channel.
- OPERATING VOLTAGE—105-125 volts, 60 cycles a.c.
- POWER CONSUMPTION—60 watts.
- RECORD CHANGER—M-40, 4 speed automatic record changer with stereophonic pickup.

VOLUME-BALANCE CONTROL

The volume-balance controls for the two amplifier channels are mounted in tandem with concentric shafts. The inner shaft is spring loaded and locked to the outer shaft. Turning the shaft of one control simultaneously turns the shaft of the other control. Pushing in the inner shaft unlocks the controls to permit individual volume control adjustment.

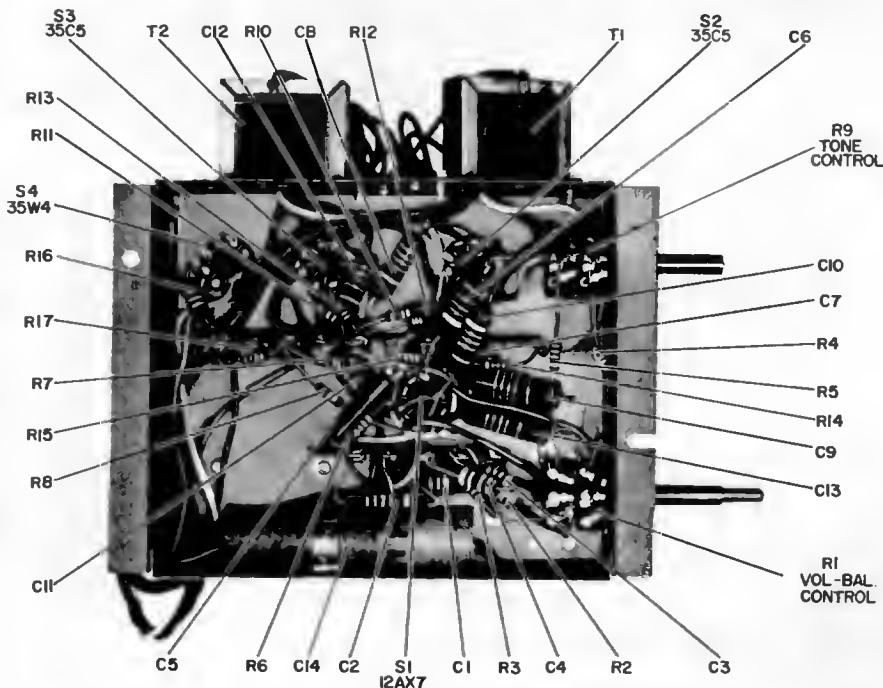
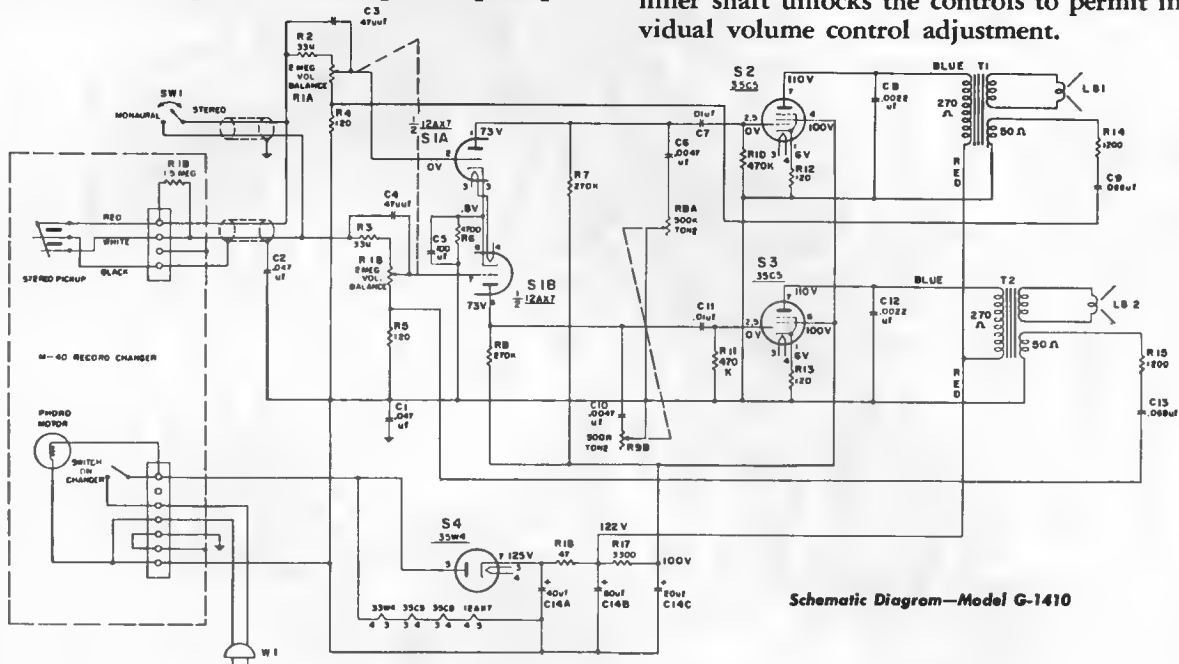

PHILCO
MODEL G-1409, CODE 124

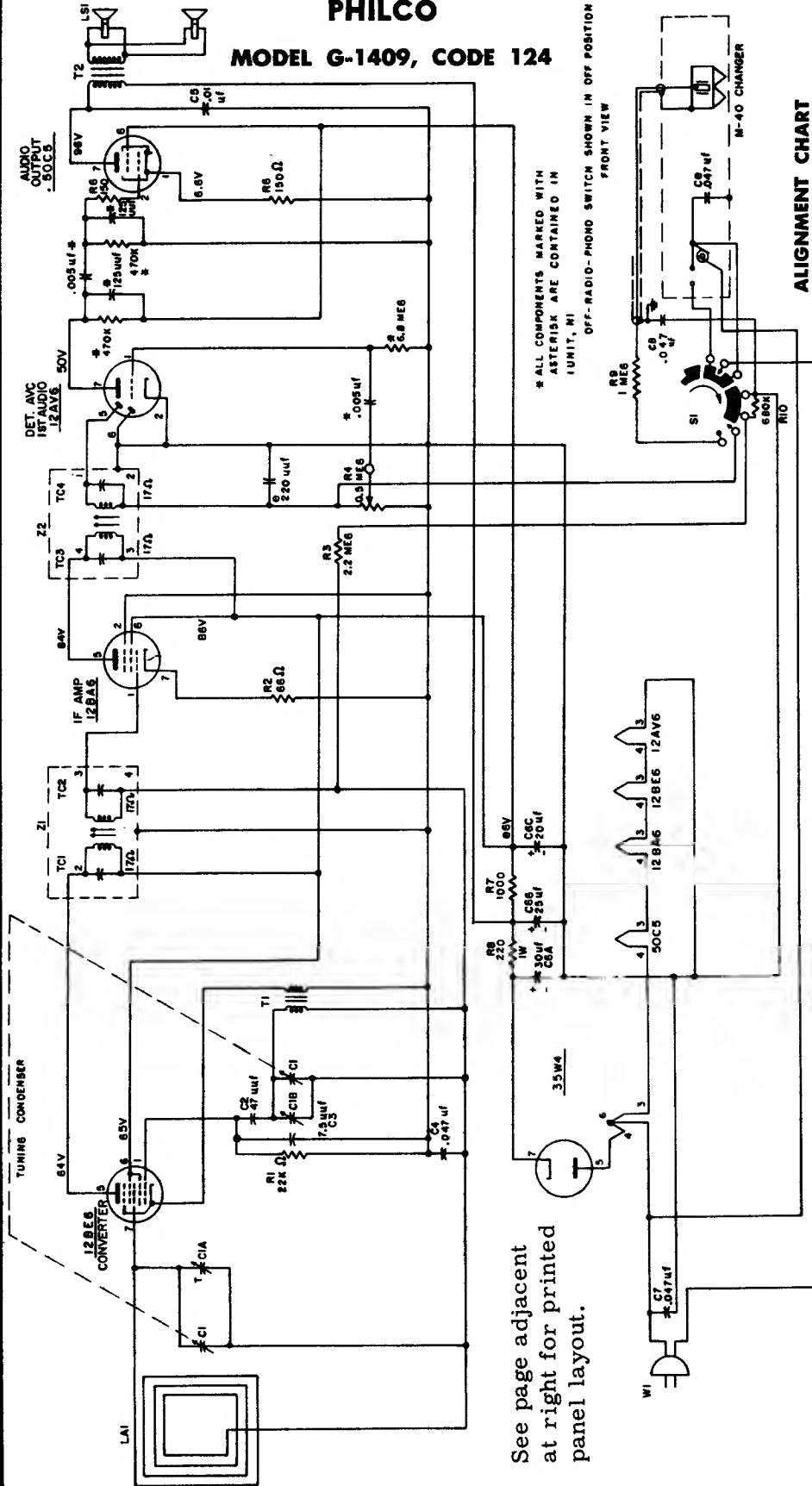

See page adjacent at right for printed panel layout.

ALIGNMENT CHART

STEP	SIGNAL GENERATOR		RADIO		ADJUST
	CONNECTION TO RADIO	DIAL SETTING	DIAL SETTING	SPECIAL INSTRUCTIONS	
1.	Ground lead to B-; output lead through .1 mf condenser to grid (pin 7) of 12BE6.	455 kc.	Tuning gang fully open.	Adjust tuning cores, in order given, for max. output. TC2 and TC4 are located on top of transformers.	TC4—2nd i-f sec. TC3—2nd i-f pri. TC2—1st i-f sec. TC1—1st i-f pri.
2.	Radiating loop (See note below).	1620 kc.	1620 kc.*	Adjust for maximum output.	C1-B—osc.
3.	Same as Step 2.	1500 kc.	1500 kc.	Adjust for maximum output.	C1-A—serial.

ALIGNMENT PROCEDURE

- Radio Controls**—Set volume control to maximum. Set tuning control as indicated in chart.
- Output Meter**—Connect across voice coil terminals.
- Signal Generator**—Connect generator and set frequency as indicated in chart. Use modulated output, 30%.
- Output Level**—During alignment, adjust signal-generator output to hold output-meter reading below .5 volts.

NOTE: Make up a 6-8 turn, 6 inch diameter loop from insulated wire, connected to signal-generator leads, and place near radio loop. For proper adjustment of the oscillator trimmer, fully open the tuning gang and insert a .006 inch non-metallic shim between the heel of the rotor and the top of the stator plates. Close the tuning gang sufficiently to hold the shim in place, and then remove

VOLUME R-19, MOST-OFTEN-NEEDED 1959 RADIO SERVICING INFORMATION

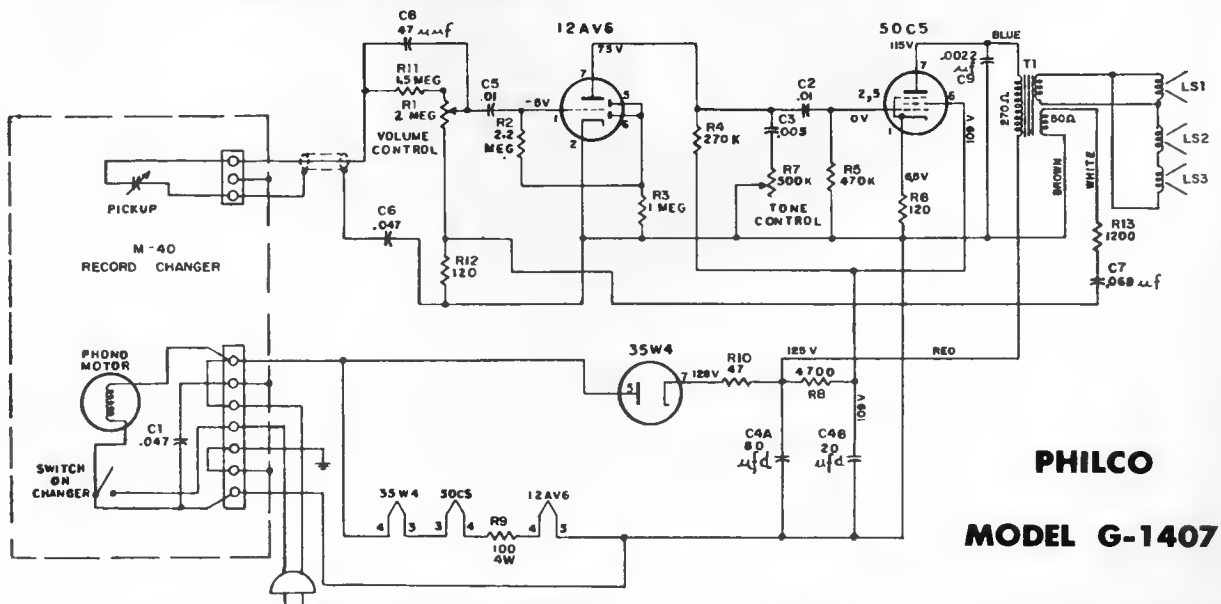
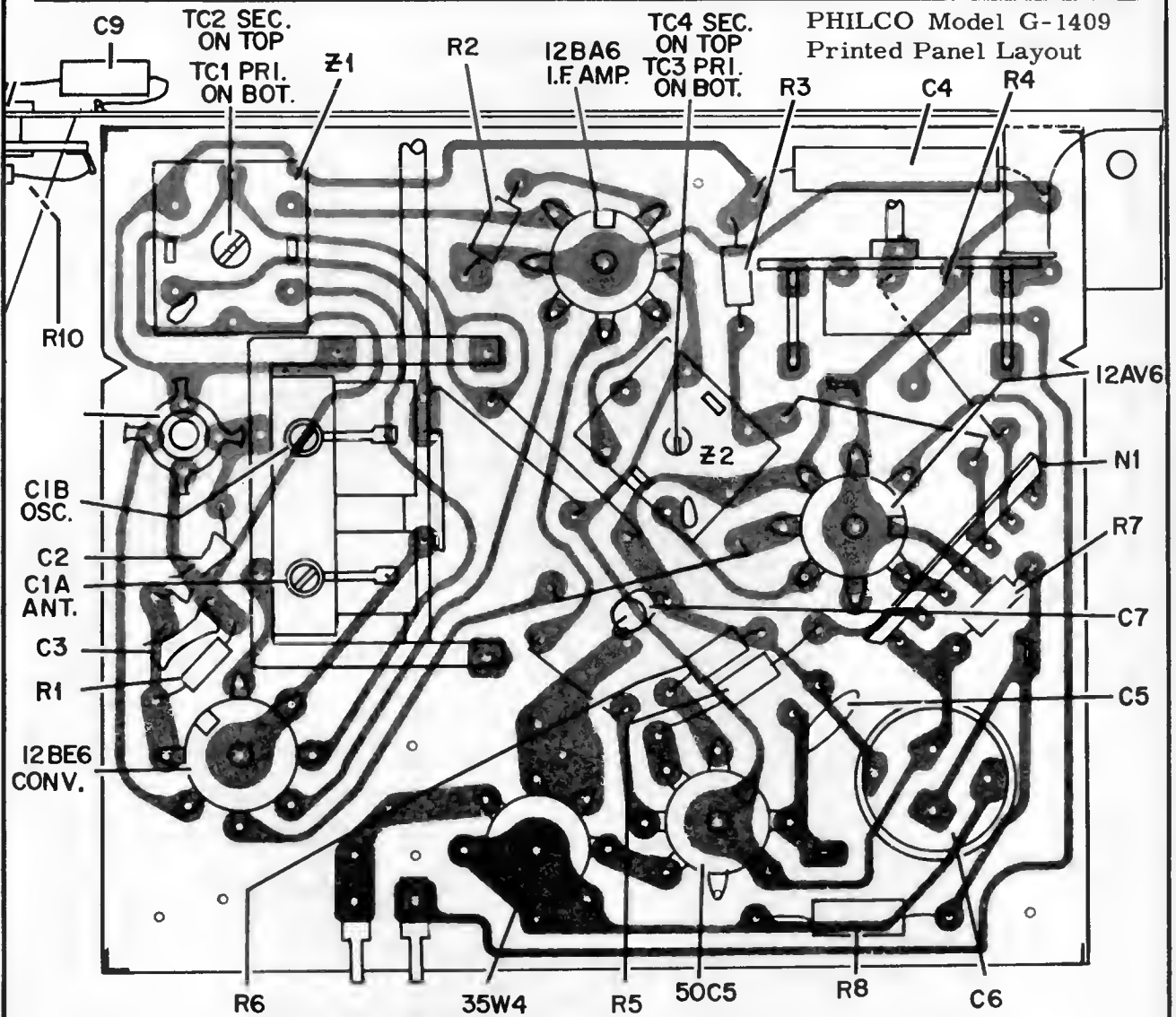

PHILCO
MODEL G-1407

PHILCO MODELS— G-1606, G-1606S-123 and SA-1000

Schematic Diagram, Model G-1606S. (See figures for Models SA-1000 and G-1606)

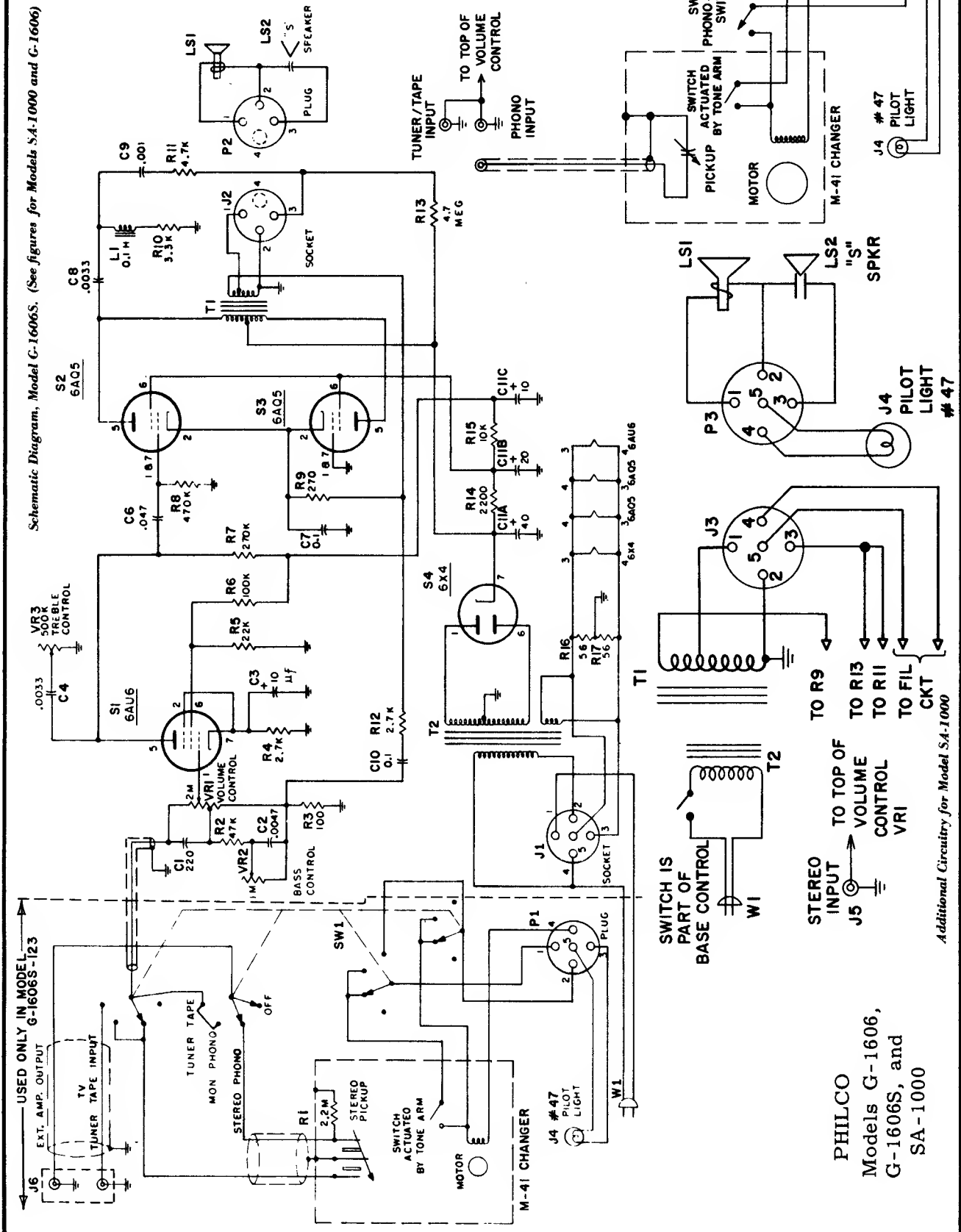

PHILCO
Models G-1606,
G-1606S, and
SA-1000

Additional Circuitry for Model SA-1000

Additional Circuitry for Model G-1606

PHILCO

MODELS G-1708S, G-1806S, G-1807S, G-1808S, G-1809S, G-1811S, G-1813S, and SA-2000

- NOTES**
1. Used only in Models G-1807S, G-1809S, G-1811S and G-1813S.
 2. 5U4GB used in Models G-1807S, G-1811S and G-1813S.
 3. 5Y3 used in Models G-1708S, G-1806S, G-1808S and SA-2000.
 4. C20 located on speaker.
 5. In Models G-1708S, G-1806S, G-1808S and SA-2000, R22 is 4700 ohms. Other models, as shown on schematic.

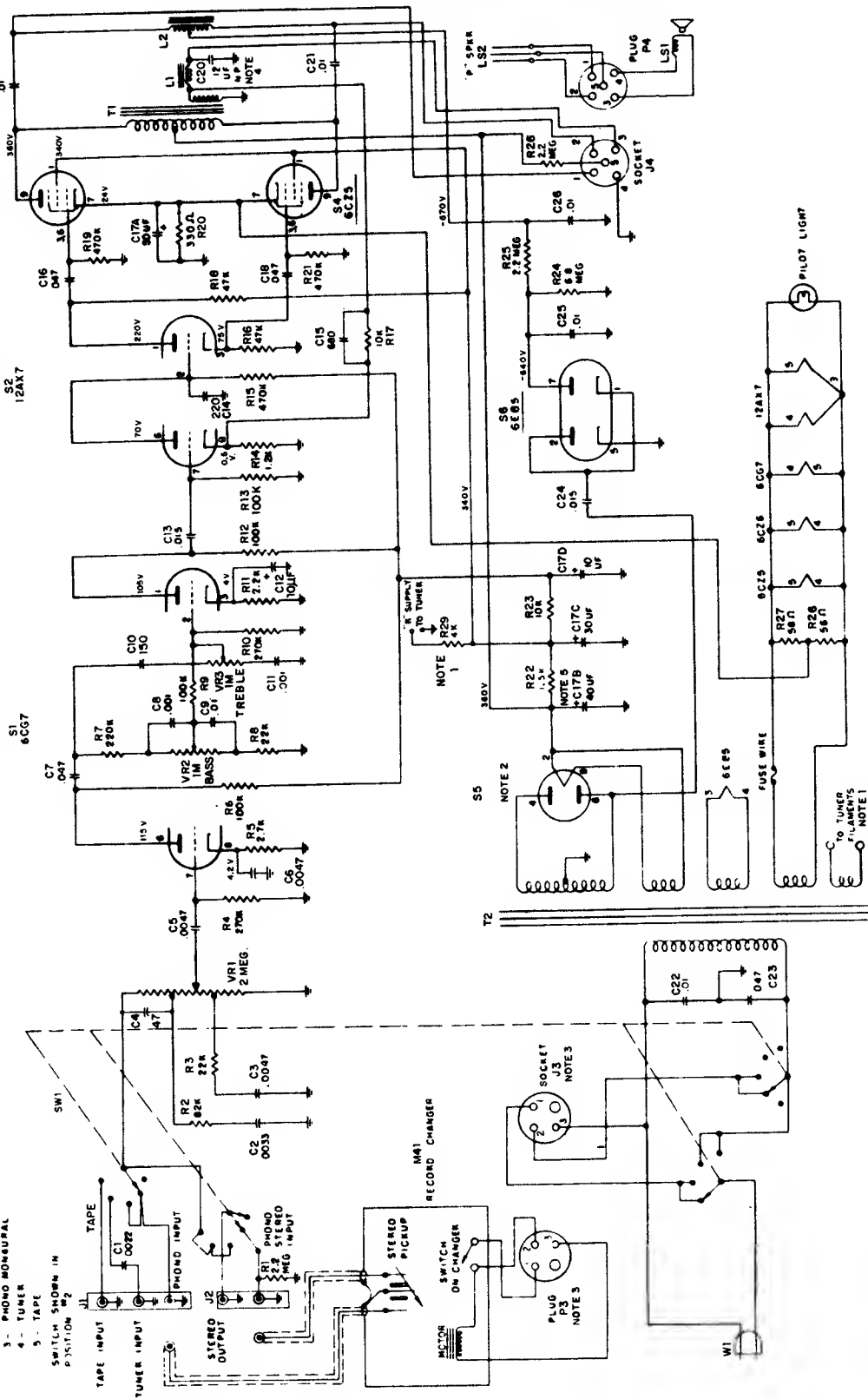

PHILCO HI-FIDELITY PHONOGRAPH MODELS—
G-1708S, G-1806S, G-1807S, G-1808S, G-1809S, G-1811S, G-1813S and SA-2000

PHILCO HI-FIDELITY PHONOGRAPHS MODELS G-1706, G-1706S, G-1707, G-1707S, SA-1500 and RT-150

(Continued on the page adjacent at right)

SPECIFICATIONS

NOTE: The G-1706 contains a three-tube-plus rectifier amplifier and a type M-41 record changer. The G-1706S is similar to the G-1706 except the function switch has a stereo position and the M-41 record changer has a stereo cartridge. The G-1707 is a G-1706 with changes to accept a radio tuner. The G-1707 includes an RT-150 AM-FM tuner. The G-1707S is similar to the G-1707 except the function switch has a stereo position and the M-41 record changer has a stereo cartridge. The SA-1500 is the slave amplifier used with the G-1706S or the G-1707S for stereo. Its amplifier is similar to the G-1706 with a different function switch and a-c wiring changes necessitated by the absence of a record changer.

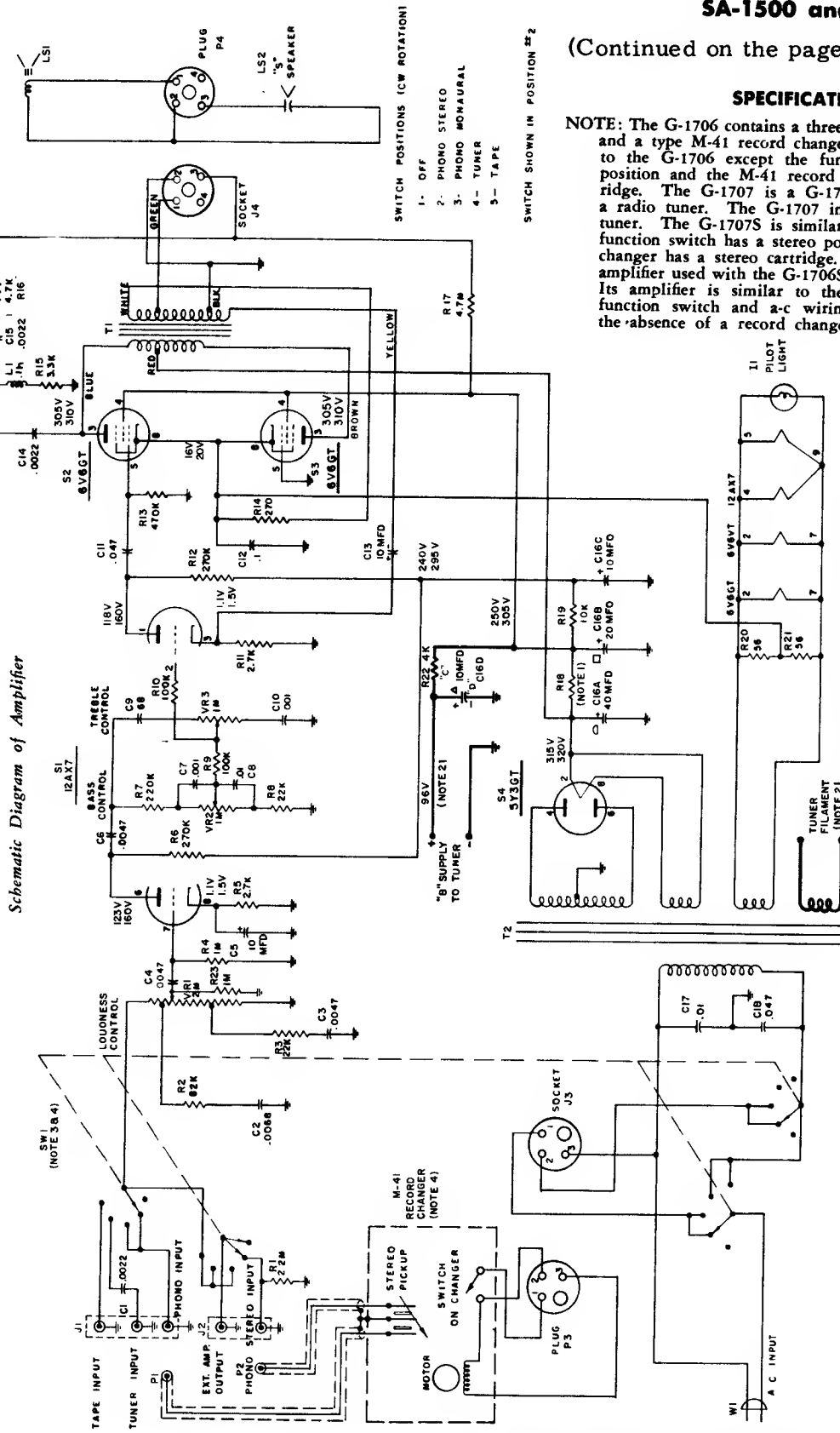

Schematic Diagram of Amplifier

PRODUCTION CHANGE

In later models, C7, C8, C9, C10, R7 and R8 of the amplifier are replaced by network, Philco part no. 58-1893. The physical location of C4 and R10 are changed to accommodate the network.

Circuit — Three-tube audio amplifier plus a rectifier. The amplifier includes bass, treble and loudness controls and a selector switch. Inputs are provided for phono stereo, (G-1706S and G-1707S only) phono monaural, tuner and tape recorder. Models G-1707 and G-1707S use the RT-150 AM-FM tuner. This tuner contains a six-tube superheterodyne circuit. Its operating voltages, B+ and filament, are supplied by the amplifier.

NOTES

1. In model G-1706, G-1706S and SA-1500, R18 is 3.3K.
2. In model G-1707 and G-1707S, R18 is 1.5K.
3. Models G-1706 and G-1707S only. The above provisions. These models differ from the schematics in that they use a four-position function switch with positions for OFF, MONAURAL and TUNER. J2 and R1 are not required in these models.
4. Model SA-1500 does not have a record changer or associated wiring. This model uses a four-position function switch with positions for OFF, MONAURAL, AUX 1 and AUX 2.
5. Voltage measurements are taken with a VTVM under no-signal conditions.
6. The test points shown for each test point. The upper one is for the G-1706 and G-1707S, the lower one is for the remaining models.

PHILCO HI-FIDELITY PHONOGRAPHS

MODELS G-1706, G-1706S, G-1707, G-1707S, SA-1500 and RT-150

(Continued from the page adjacent at left.)

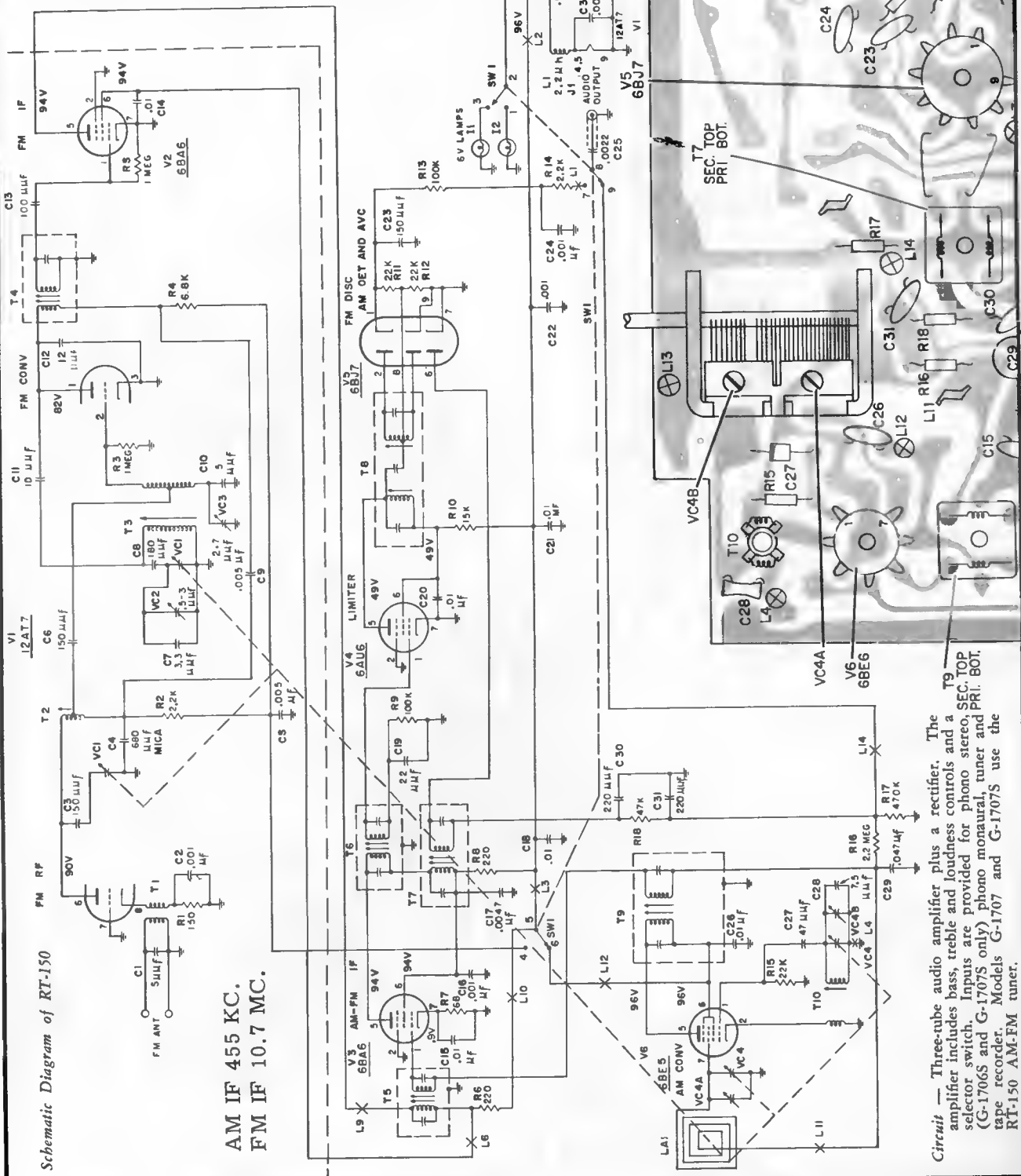

Schematic Diagram of RT-150

AM IF 455 KC.
FM IF 10.7 MC.

Circuit — Three-tube audio amplifier plus a rectifier. The amplifier includes bass, treble and loudness controls and a selector switch. Inputs are provided for phono stereo, SEC. TOP (G-1706S and G-1707S only) phono monaural, tuner and PRI. BOT. tape recorder. Models G-1707 and G-1707S use the RT-150 AM-FM tuner.

Part of printed wiring panel of RT-150



RCA VICTOR

Amplifier/Speaker Combination MODELS SA-2 and SA-3 Amp. Chassis No. RS-151B

RESISTANCE VALUES IN OHMS. K=1000
CAPACITANCE VALUES LESS THAN 1. IN
MICRO FARADS ABOVE IN MMF. UNLESS OTHER-
WISE NOTED.
DIRECTION OF ARROWS AT CONTROLS
INDICATES CLOCKWISE ROTATION.
VOLTAGES MEASURED WITH 1/2 VOLT
OHMMETER WITH FUNCTION SW. S1 IN
A.M. RADIO POSITION; AND SHOULD HOLD
WITHIN ±20% WITH 117 V. A.C. SUPPLY.

Schematic Diagram of Amplifier RS-151B

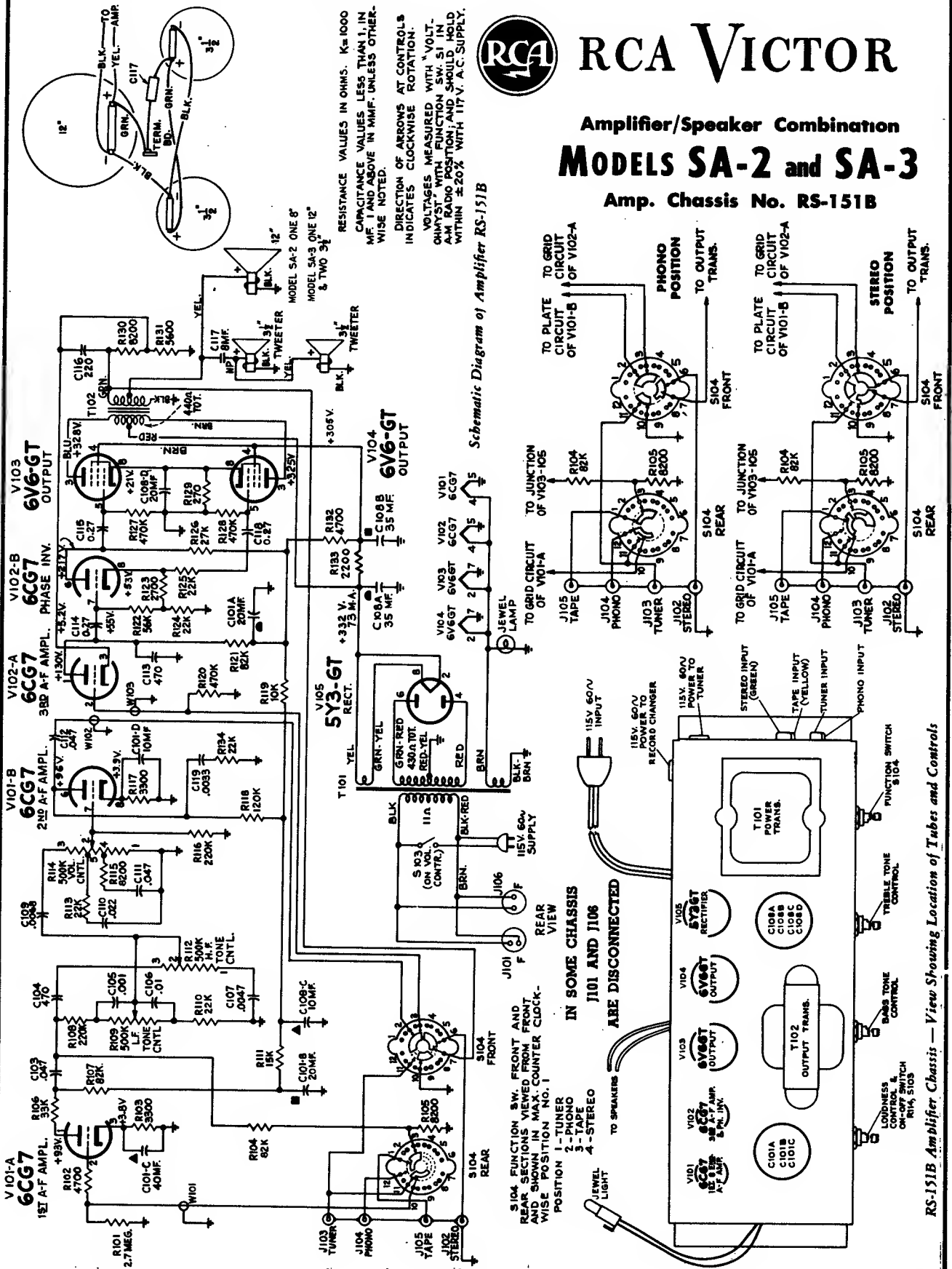

Simplified Schematic Diagrams of Function Switch in Amplifier Chassis RS-151B

RS-151B Amplifier Chassis — View Showing Location of Tubes and Controls



RCA VICTOR

MODEL HF-99

Chassis No. RS-157D

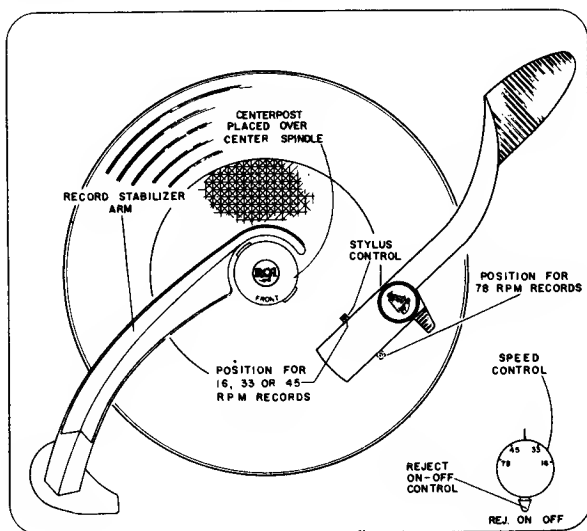

Record Changer Controls

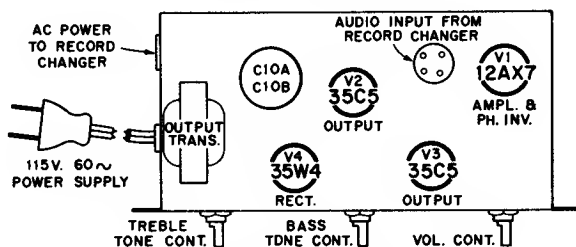

View of Amplifier Chassis Showing Location of Tubes and Major Components

CRITICAL LEAD DRESS

1. Dress all heater leads and power cord close to chassis and away from 12AX7 tube socket and phono input jack to maintain low hum level.
2. Keep shielded lead W1, including shield connections, as short as possible.
3. Dress record changer power cable and pickup cable as far apart as possible to minimize hum pickup.

NOTE—The "ON-OFF" switch is not part of the volume control. The record changer must be "ON" for power to be applied to the amplifier.

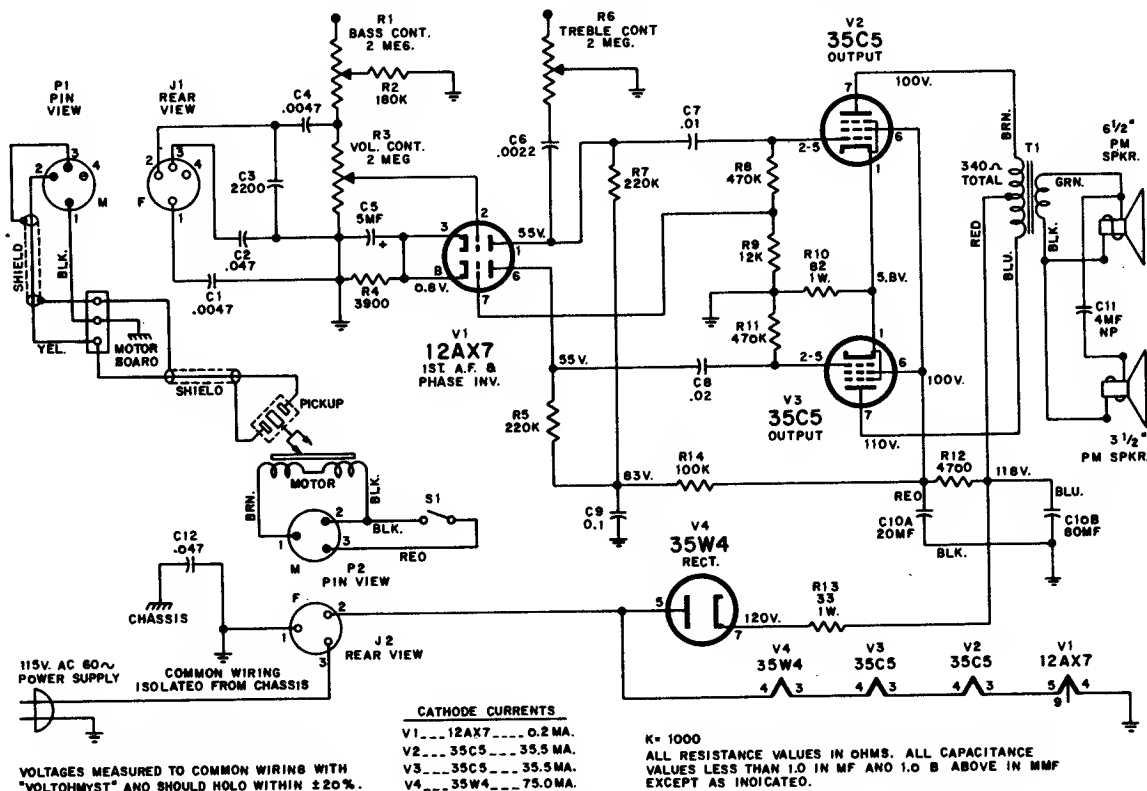



RCA VICTOR

SHP-11 STEREO RECORD PLAYER Chassis RS-171A

SHS-11 SPEAKER CABINET

TO EXTERNAL SPEAKERS
FOR LEFT CHANNEL

INTERNAL SPEAKERS
FOR RIGHT CHANNEL

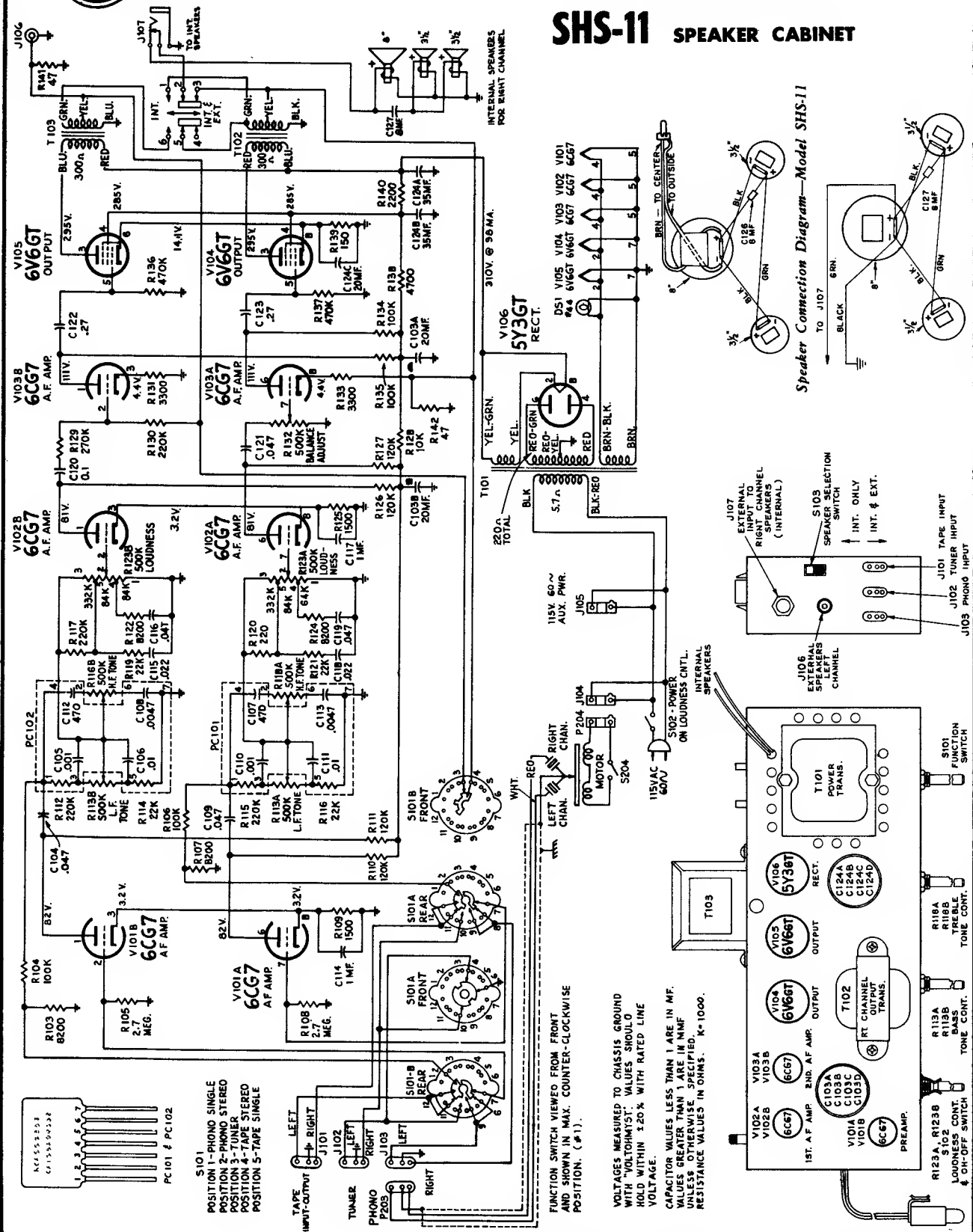

Speaker Connection Diagram—Model SHS-11

Speaker Connection Diagram—Model SHP-11

S101
POSITION 1—PHONO SINGLE
POSITION 2—PHONO STEREO
POSITION 3—TUNER
POSITION 4—TAPE STEREO
POSITION 5—TAPE SINGLE

FUNCTION SWITCH VIEWED FROM FRONT
AND SHOWN IN MAX. COUNTER-CLOCKWISE
POSITION. (#1).

VOLTAGES MEASURED TO CHASSIS GROUND
WITH "VOLTOHMS" VALUES SHOULD
HOLD WITHIN ±20% WITH RATED LINE
VOLTAGE.
CAPACITOR VALUES LESS THAN 1 ARE IN MF.
RESISTOR VALUES LESS THAN 100 ARE IN OHMS
UNLESS OTHERWISE SPECIFIED. SPMS. K=1000.
RESISTANCE VALUES IN OHMS. K=1000.

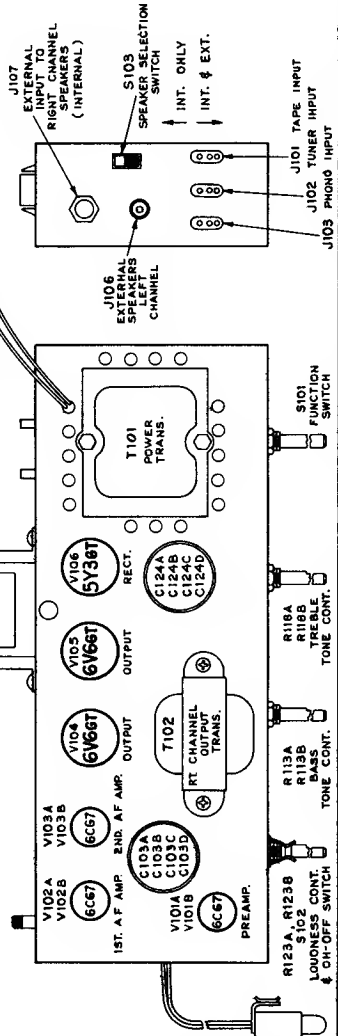

RCA VICTOR

MODELS SHP-12, SHP-13, TYPE AK-1

Chassis No. RS-172

ACCESS TO TUBES AND CHASSIS

Model SHP-12

Turn cabinet on its side and remove ten wood screws holding the bottom cover to the cabinet.

Model SHP-13

Remove inside front panel held by screws. Remove control knobs. Remove screws at edges of record changer mounting board; tilt board upward.

CRITICAL LEAD DRESS

Dress heater leads close to chassis.

Dress all leads away from phono input socket. Keep leads of C4 and C7 as short as possible and dress all other components away from these capacitors.

Record changer motor leads must be twisted to minimize hum.

NOTE—The "ON-OFF" switch is not part of the volume control. The record changer must be "ON" for power to be applied to the amplifier.

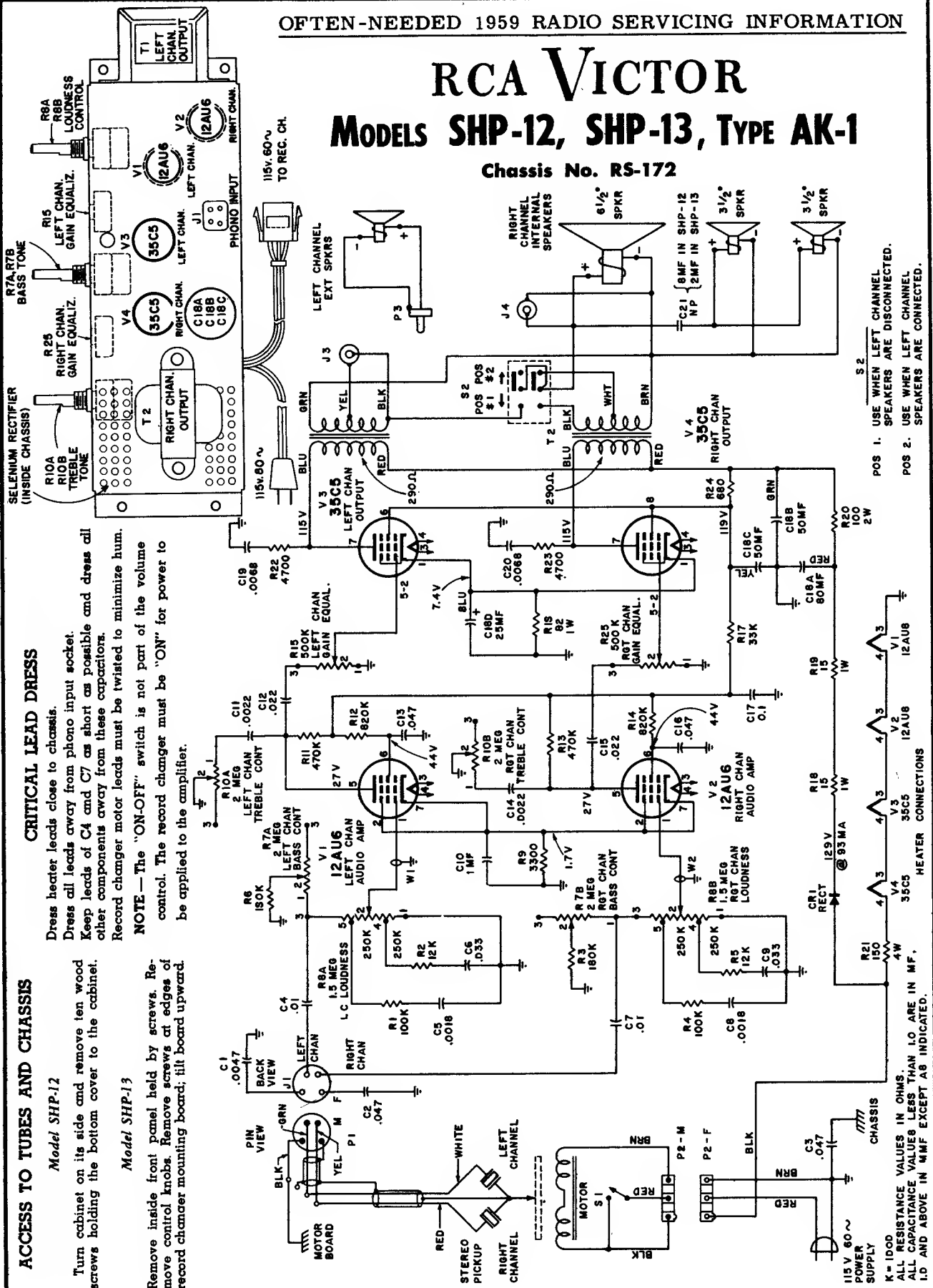

POS 1. USE WHEN LEFT CHANNEL SPEAKERS ARE DISCONNECTED.
 POS 2. USE WHEN LEFT CHANNEL SPEAKERS ARE CONNECTED.

HEATER CONNECTIONS
 V1 12AU6
 V2 12AU6
 V3 35C5
 V4 35C5

K = 1000
 ALL RESISTANCE VALUES IN OHMS.
 ALL CAPACITANCE VALUES LESS THAN 1.0 ARE IN MF.
 1.0 AND ABOVE IN μ MF EXCEPT AS INDICATED.



RCA VICTOR

MODEL SES-6

Chassis No. RS-175

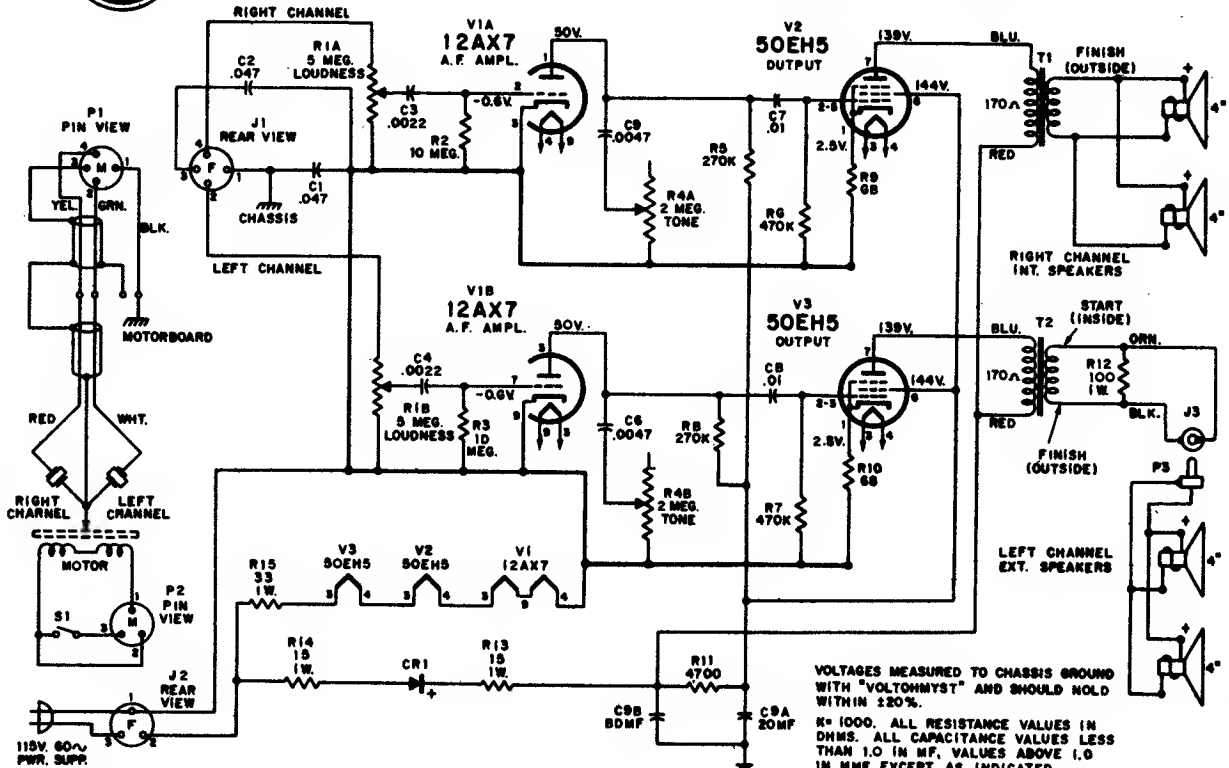

SPEAKER PHASING

The two speaker systems must be properly connected in order to have in-phase sound outputs. Incorrect connections will be evidenced by a "null point" in the sound when playing

a monaural record and listening from a point midway between the two speaker systems. For the same reason both speakers in each system should be phased with each other.

VOLTAGES MEASURED TO CHASSIS GROUND WITH "VOLTOHMYST" AND SHOULD HOLD WITHIN ±20%.
 N=1000. ALL RESISTANCE VALUES IN OHMS. ALL CAPACITANCE VALUES LESS THAN 1.0 IN MF. VALUES ABOVE 1.0 IN MMF EXCEPT AS INDICATED.

REPLACEMENT PARTS

Symbol No.	Stock No.	Description	Symbol No.	No. Stock	Description
AMPLIFIER ASSEMBLY RS-175			RECORD CHANGER WIRING		
CAPACITORS:			P1	101748	Connector—4-contact male for pickup cable
C1, C2	73553	paper, 0.047 mf., +100-0%, 400 v.	P2	101747	Connector—3-contact male for motor cable
C3, C4	77953	ceramic, 0.0022 mf., ±20%, 500 v.		101825	Connector—Closed end, for motor lead
C5, C6	103905	ceramic, 0.0047 mf., ±20%, 1000 v.		76301	Switch—"ON-OFF" power switch
C7, C8	73960	ceramic, 0.01 mf., +100-0%, 500 v.	SPEAKER ASSEMBLY		
C9A, C9B	101752	electrolytic, 80/20 mf., 150/150 v.		31048	Connector—Single contact male for remote speaker cable
CR1	106967	Rectifier—Silicon		79696-A	Speaker—4" PM
J1	101749	Connector—4-contact female with retainer for pickup cable			
J2	101750	Connector—3-contact female with retainer for motor-cable			
RESISTORS:					
Fixed, Composition, unless otherwise specified:					
R1A, R1B	106969	Control—Dual volume 10 megohm, ±20%, ½ w.			
R2, R3		Control—Dual tone 270,000 ohm, ±10%, ½ w.			
R4A, R4B	106968	Control—Dual tone 470,000 ohm, ±20%, ½ w.			
R5		270,000 ohm, ±10%, ½ w.			
R6, R7		470,000 ohm, ±20%, ½ w.			
R8		270,000 ohm, ±10%, ½ w.			
R9, R10		68 ohm, ±10%, ½ w.			
R11		4700 ohm, ±20%, ½ w.			
R12		100 ohm, ±20%, 1 w.			
R13, R14		15 ohm, ±20%, 1 w.			
R15		33 ohm, ±20%, 1 w.			
T1, T2	100272	Transformer—Output			
	70392	Cable—AC power cable with plug			
	74822	Socket—7-pin miniature for V2 and V3			
	79799	Socket—9-pin miniature for V1			

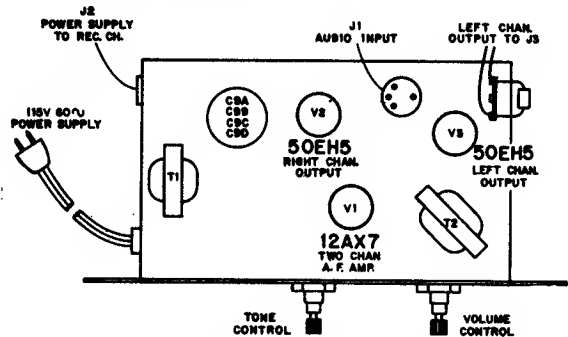

View of Chassis Showing Location of Tubes and Major Components

RCA VICTOR MODEL SHP-14

Chassis No. RS-175A

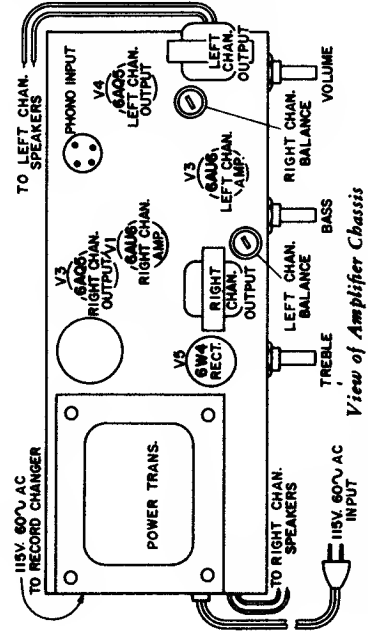
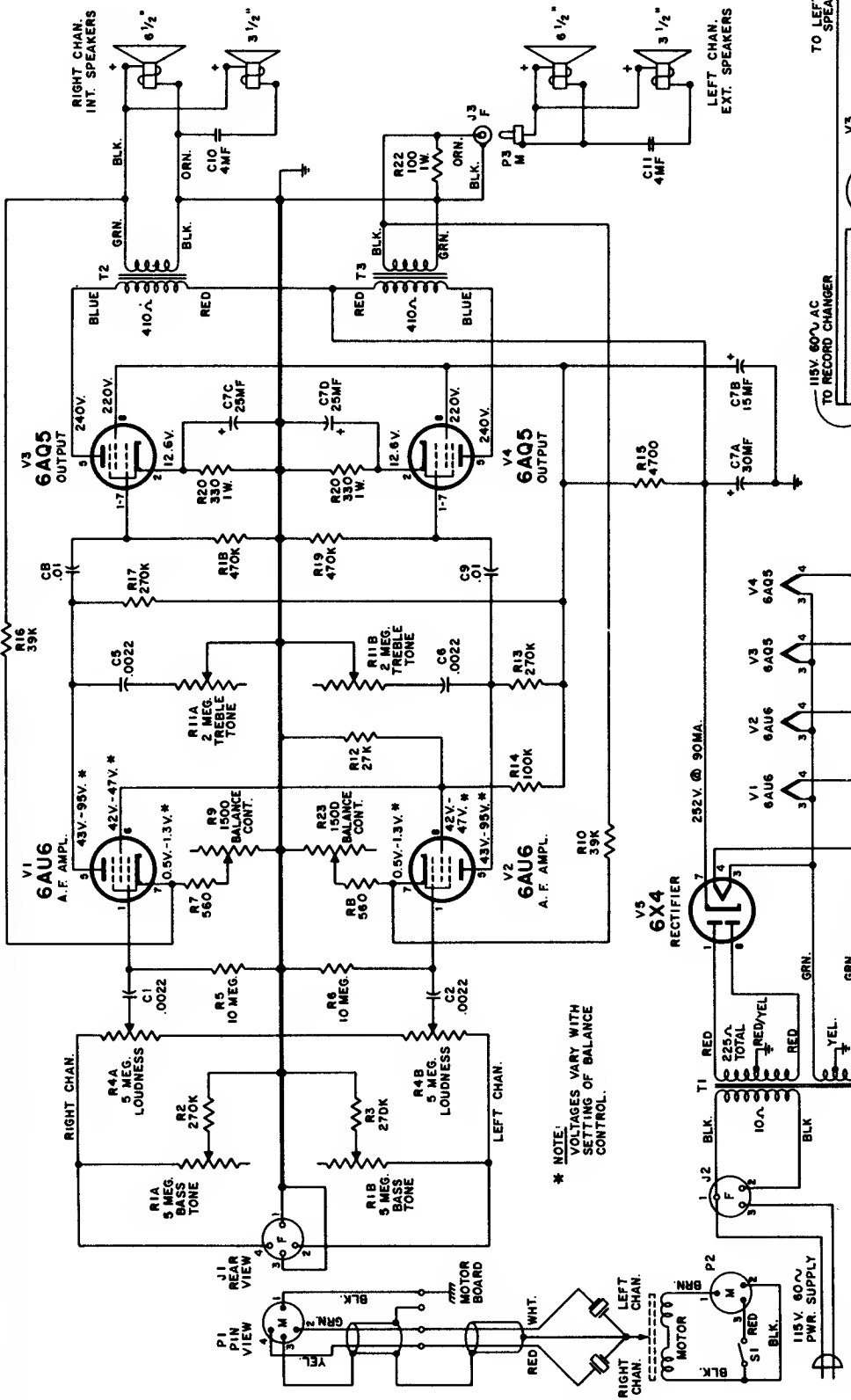

VOLTAGES MEASURED TO CHASSIS GROUND WITH "VOLTOHMYST" AND SHOULD HOLD WITHIN $\pm 20\%$.

K = 1000. ALL RESISTANCE VALUES IN OHMS. ALL CAPACITANCE VALUES LESS THAN 1.0 IN MF. VALUES ABOVE 1.0 IN MMF EXCEPT AS INDICATED.

NOTES

It is not necessary to measure the audio output while making the equalization adjustment; sufficient accuracy can usually be had by listening. This is best done by playing a monaural record with the left channel speaker placed for stereo listening. Adjust one balance control so that the combined sound of the two speakers appears to come from a point midway between the two speakers.

If the external speaker system is other than 3.2 ohms impedance, the output voltages will not be equal for equal power output.

NOTE—The "ON-OFF" switch is not part of the volume control. The record changer must be "ON" for power to be applied to the amplifier.

* NOTE: VOLTAGES VARY WITH SETTING OF BALANCE CONTROL.



RCA VICTOR

Model 9-TX-2, Chassis RC-1156C

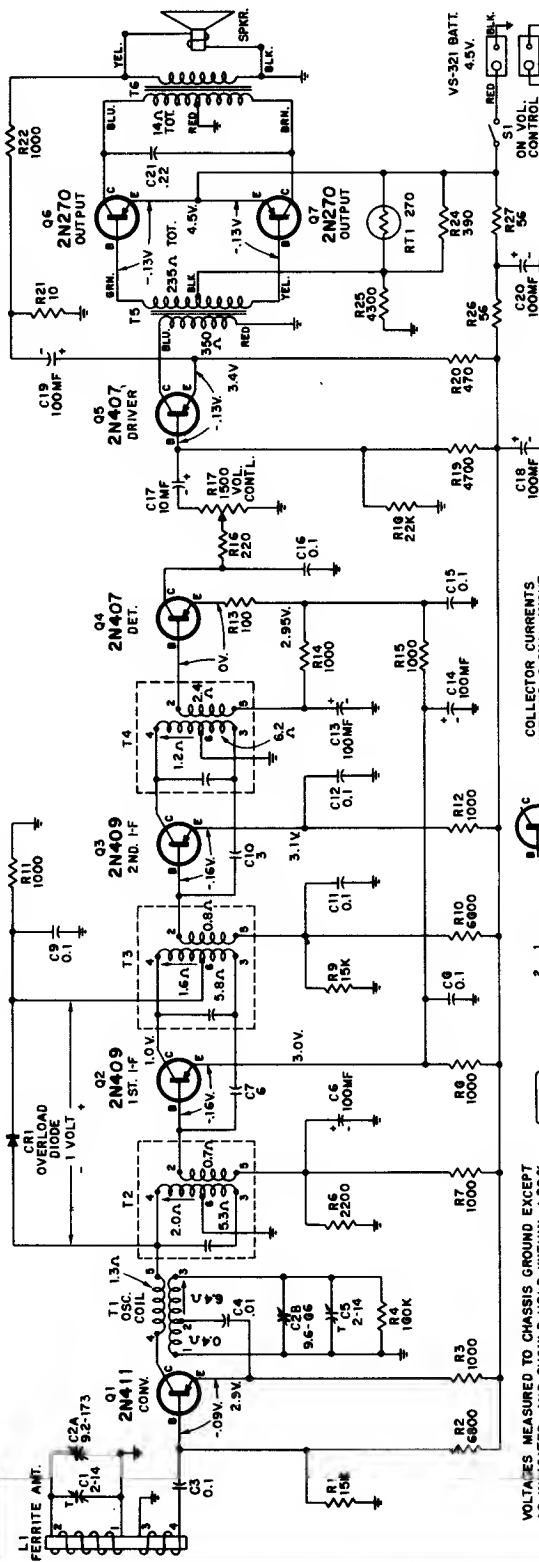

VOLTAGES MEASURED TO CHASSIS GROUND EXCEPT AS INDICATED, AND SHOULD HOLD WITHIN ±2.0% WITH NEW BATTERIES.

COLLECTOR CURRENTS WITH NO SIGNAL INPUT

Q1	0.82 MA.
Q2	0.9 MA.
Q3	0.9 MA.
Q4	0.9 MA.
Q5	0.9 MA.
Q6+Q7	5.2 MA.

TRANSISTOR CONNECTIONS

E	B	C
B	B	B

OSC. COIL COIL END VIEW

TERM. CONN. FOR T2, T3 & T4

2	3	4
0	0	0
4	0	0

ALL RESISTANCE VALUES IN OHMS. ALL CAPACITANCE VALUES LESS THAN 1.0 IN MF. AND 1.0 & ABOVE IN MMF. EXCEPT THOSE INDICATED.

ANTENNA

TUNING CONTROL

VOLUME CONTROL & ON-OFF SWITCH

T5 DRIVER TRANS.

T6 OUTPUT TRANS.

Q1 2N411 CONV.

Q2 2N409 1ST I-F TRANS. 455 KC

Q3 2N409 2ND I-F TRANS. 455 KC

Q4 2N407 DET.

Q5 2N407 DRIVER

Q6 2N270 2ND I-F TRANS. 455 KC

Q7 2N270 OUTPUT AUDIO DRIVER

T1 OSC. COIL 600 KC

T2 1ST I-F TRANS. 455 KC

T3 2ND I-F TRANS. 455 KC

T4 3RD I-F TRANS. 455 KC

T5 DRIVER TRANS.

T6 OUTPUT TRANS.

C1 1400 KC ANT. OSC.

C2A ANT.

C2B OSC.

C3 1620 KC OSC.

C4 2N407 DET.

C5 1620 KC OSC.

C6 1000

C7 1000

C8 1000

C9 0.1

C10 1000

C11 0.1

C12 0.1

C13 1000

C14 1000

C15 0.1

C16 0.1

C17 10MF

C18 100MF

C19 100MF

R1 5K

R2 6800

R3 1000

R4 100K

R5 1000

R6 2200

R7 1000

R8 1000

R9 15K

R10 6800

R11 1000

R12 1000

R13 100

R14 1000

R15 1000

R16 220

R17 100

R18 22K

R19 4700

R20 470

R21 10

R22 1000

R23 350

R24 350

R25 4300

R26 470

R27 56

VS-321 BATT. 4.5V.

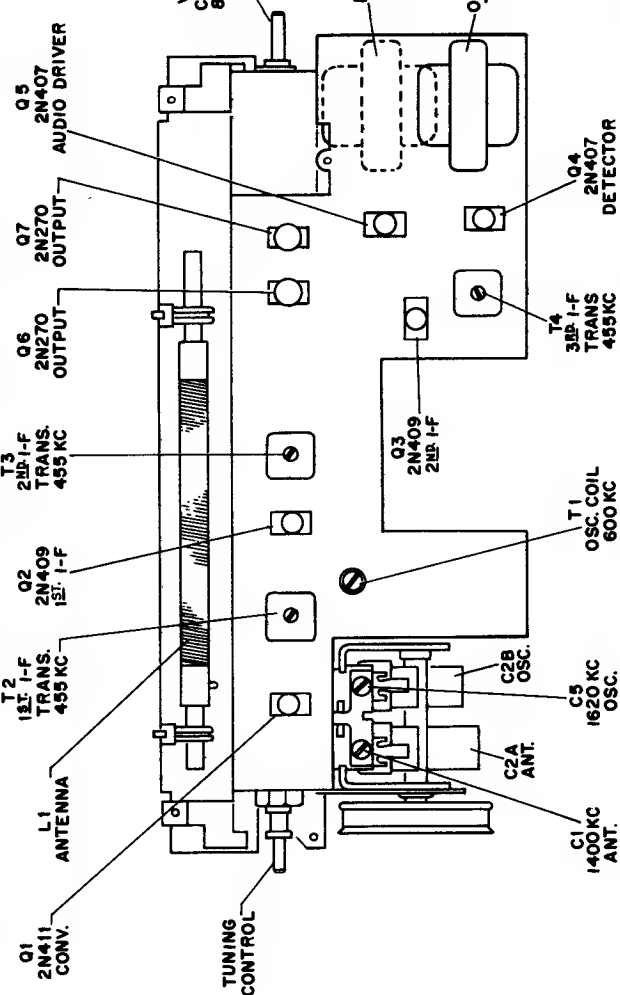

- CRITICAL LEAD DRESS**
1. Dress all bus and non-insulated pigtail leads away from chassis ground and other components to prevent shorts.
 2. Dress loop antenna leads direct and away from chassis, call other insulated leads down against chassis.
 3. Dress RT1 (thermistor) away from all other components.
 4. Maintain reasonably short pigtail leads on components associated with the detector circuit, to limit 910 kc "tweak."
 5. Insure good grounding of shield cover.
 6. Dress components which are enclosed in shielded compartment in such manner that short circuits are prevented.
- Tuning Drive Cords**
- DIAL CORD AND POINTER ASSEMBLY SHOWN WITH GANG CONDENSER IN MAX. CLOCKWISE (CLOSED) POSITION.
- CORD NO. 1 = 6 3/4"
 CORD NO. 2 = 9 1/4"
 CORD NO. 3 = 18 1/2"
 CORD NO. 4 = 15 1/2"

RCA VICTOR MODEL BC-3 MODEL BCS-4

Battery Charger Battery Charger/Speaker

MODEL 1-BT-2 SERIES

Chassis No. RC-1187

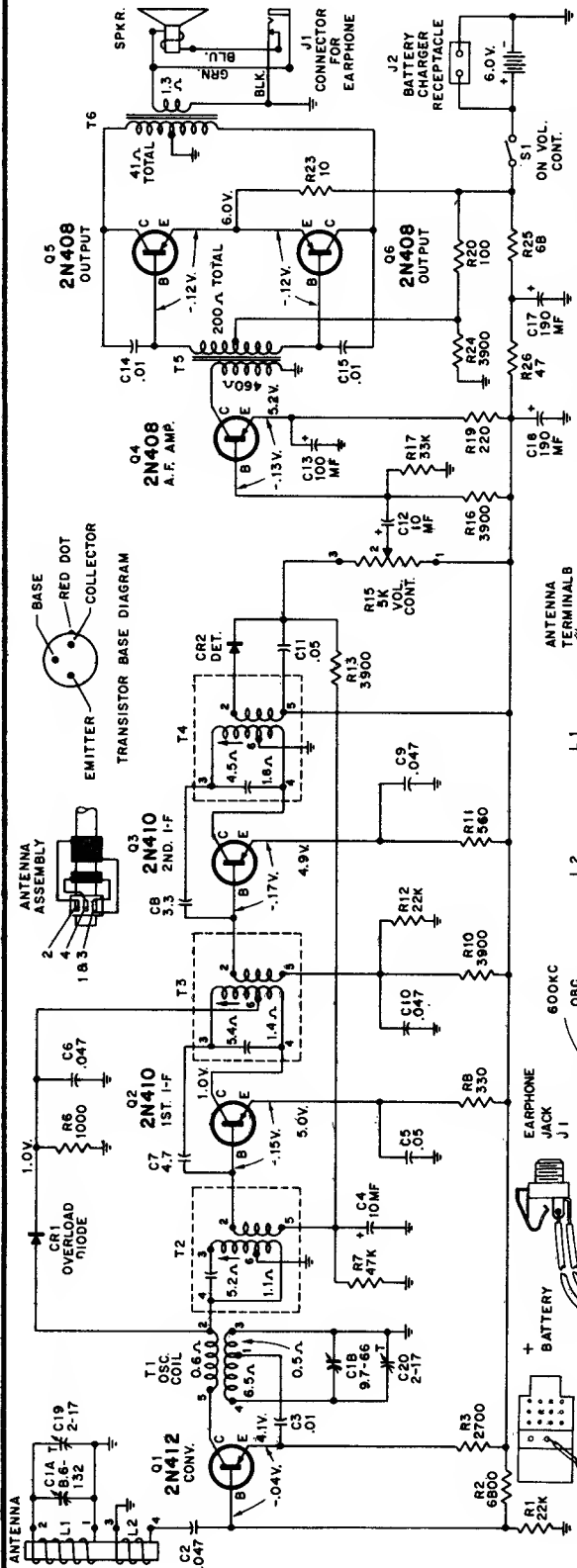

VOLTAGES MEASURED WITH "VOLTOHMYST" SHOULD HOLD WITHIN ±20% WITH NEW BATTERY. K=1000. ALL RESISTANCE VALUES IN OHMS. ALL CAPACITANCE VALUES LESS THAN 1.0 IN MF AND 1.0 & ABOVE IN MMF EXCEPT THOSE INDICATED.

EMITTER CURRENTS WITH 6.0V. BATTERY AND NO SIGNAL INPUT CURRENT

Q1	0.5 MA
Q2	0.95 MA
Q3	1.0 MA
Q4	1.5 MA
Q5	2.5 MA
Q6	2.5 MA

TOTAL BATTERY CURRENT

B MA	0
21 MA	20 MW
28 MA	50 MW
42 MA	MAX.

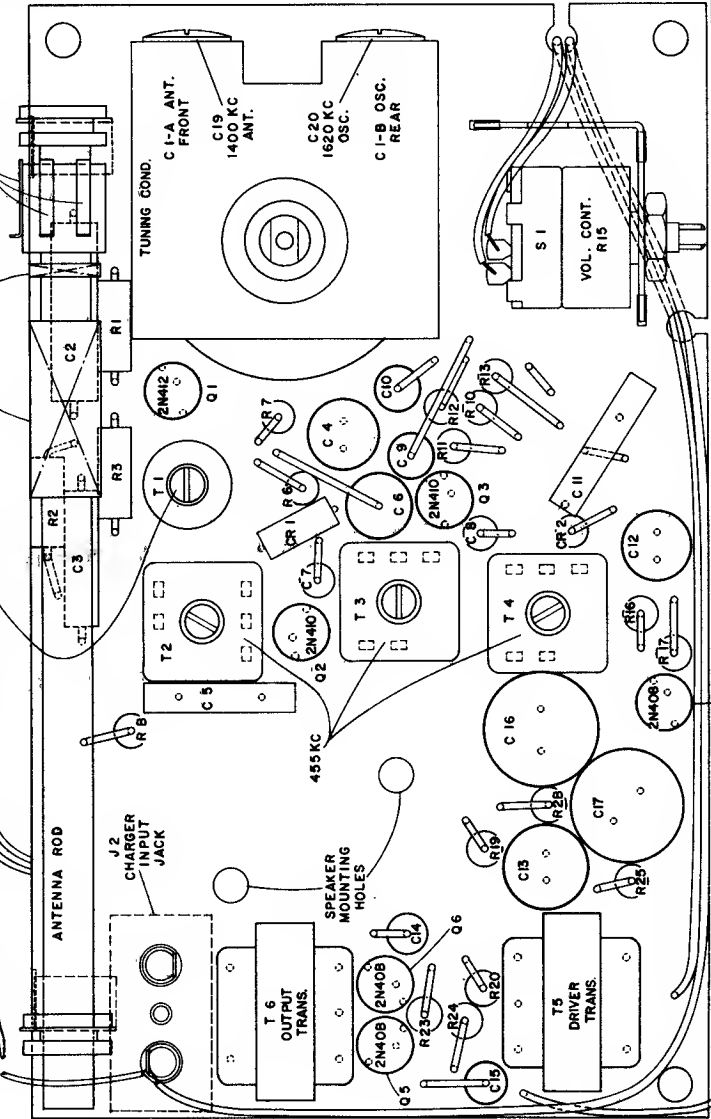
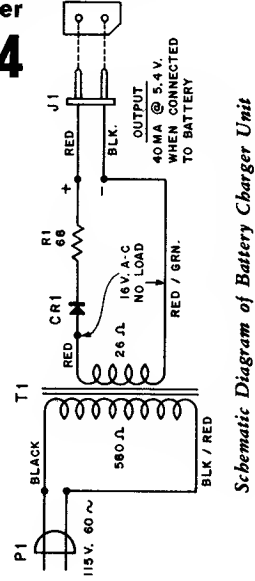
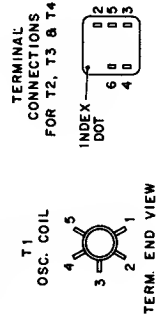

Schematic Diagram of Battery Charger Unit

RCA Victor Model 1-BT-3, Chassis RC-1187A

RCA VICTOR

MODEL 1-BT-3 Series

Chassis No. RC-1187A

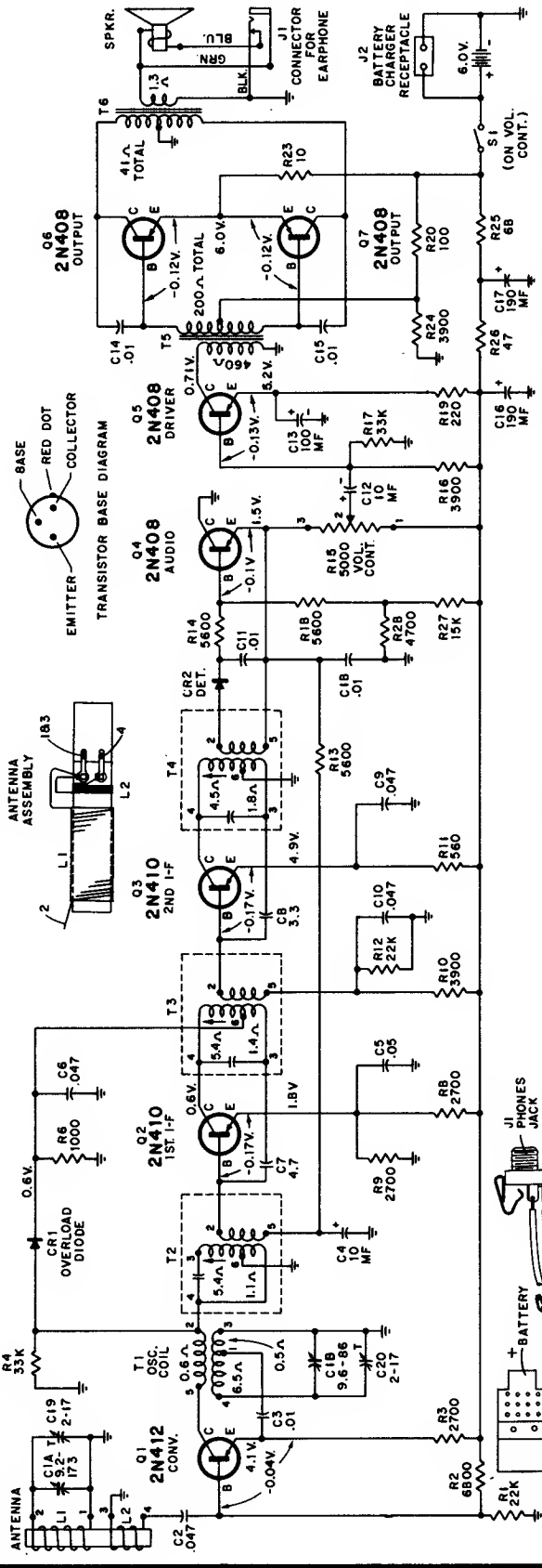

VOLTAGES MEASURED WITH "VOLTOHMYST" SHOULD HOLD WITHIN $\pm 20\%$ WITH NEW BATTERY. K=1000. ALL RESISTANCE VALUES IN OHMS. ALL CAPACITANCE VALUES LESS THAN 1.0 IN MF AND 1.0 & ABOVE IN MMF EXCEPT THOSE INDICATED.

EMITTER CURRENTS WITH 6.0V. BATTERY AND NO SIGNAL INPUT

Q1	0.5 MA
Q2	0.6 MA
Q3	1.0 MA
Q4	0.7 MA
Q5	1.5 MA
Q6	2.5 MA
Q7	2.5 MA

TOTAL BATTERY CURRENT

CURRENT	OUTPUT
B.8 MA	0
22 MA	20 MW
29 MA	50 MW
43 MA	MAX.

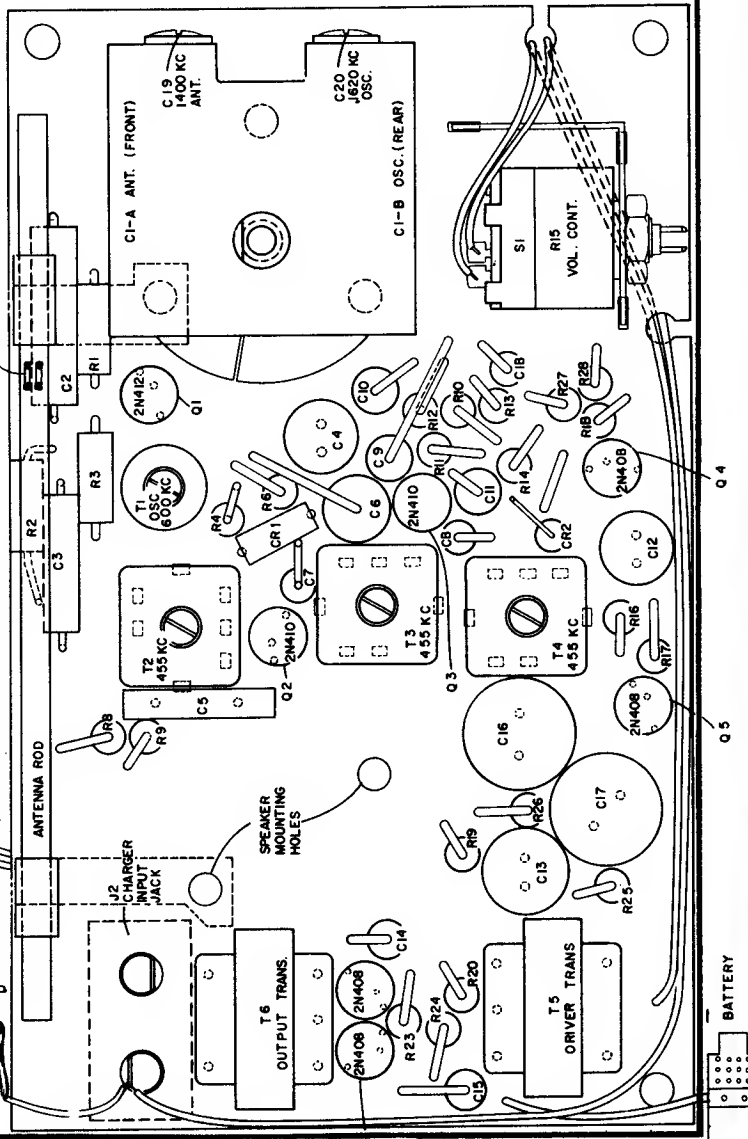
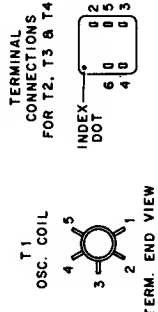

Q6
Q7

RCA VICTOR

AC-DC Radio Receiver X-1, X-2 SERIES Chassis No. RC-1188

C-1 Series, Chassis RC-1188A, is almost identical except for clock timer with its switch circuit.

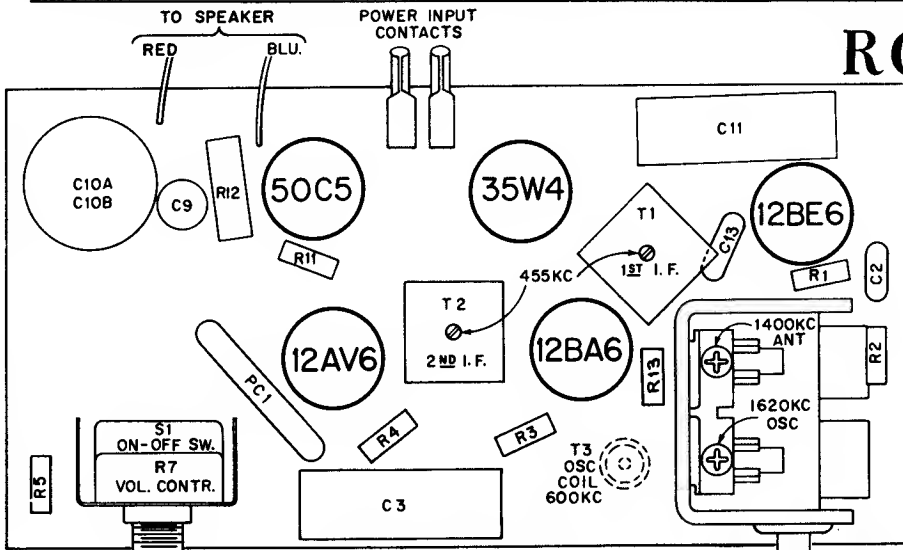

Tube and Trimmer Locations

CHASSIS REMOVAL

1. Remove three cabinet holding screws; two at back of top lip and one at bottom front.
2. Grip cabinet with two hands allowing fingers to extend over edges of cabinet front.
3. Hold cabinet, front down, and shake in a vertical direction. Cabinet assembly will separate and the fingers will limit the separation.
4. The cabinet front and chassis assembly may now be separated completely.

CABINET REASSEMBLY

1. Place chassis front and chassis assembly on the cabinet back so that the ribs of the cabinet front rest on the bottom — inside of the cabinet back.
2. Push cabinet sections together firmly.
3. Insert three holding screws; two at back of top lip and one at bottom front.

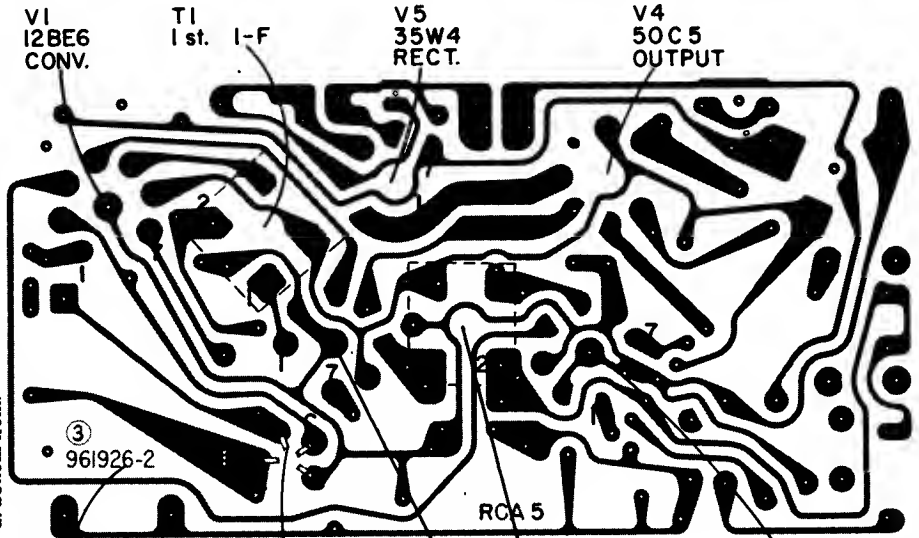

Chassis Wiring and Components — View from Wiring Side

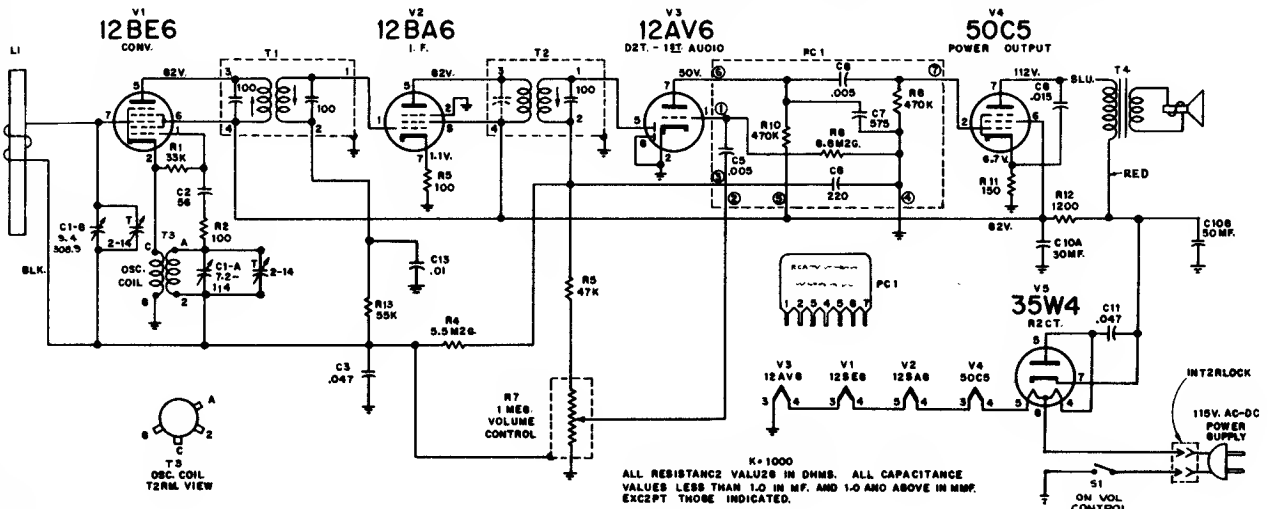

K=1000
ALL RESISTANCE VALUES IN OHMS. ALL CAPACITANCE VALUES LESS THAN 1.0 IN MF. AND 1.0 AND ABOVE IN MMF. EXCEPT THOSE INDICATED.

Roland

MODEL 71-483

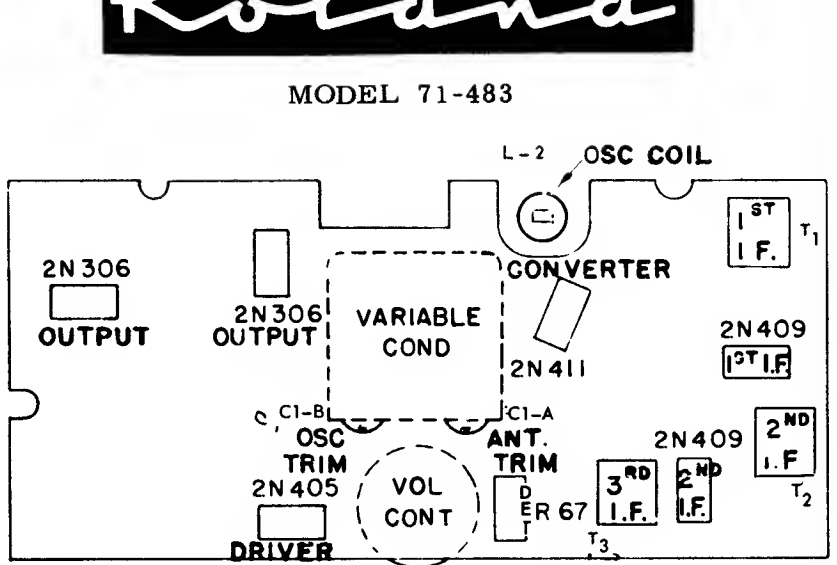
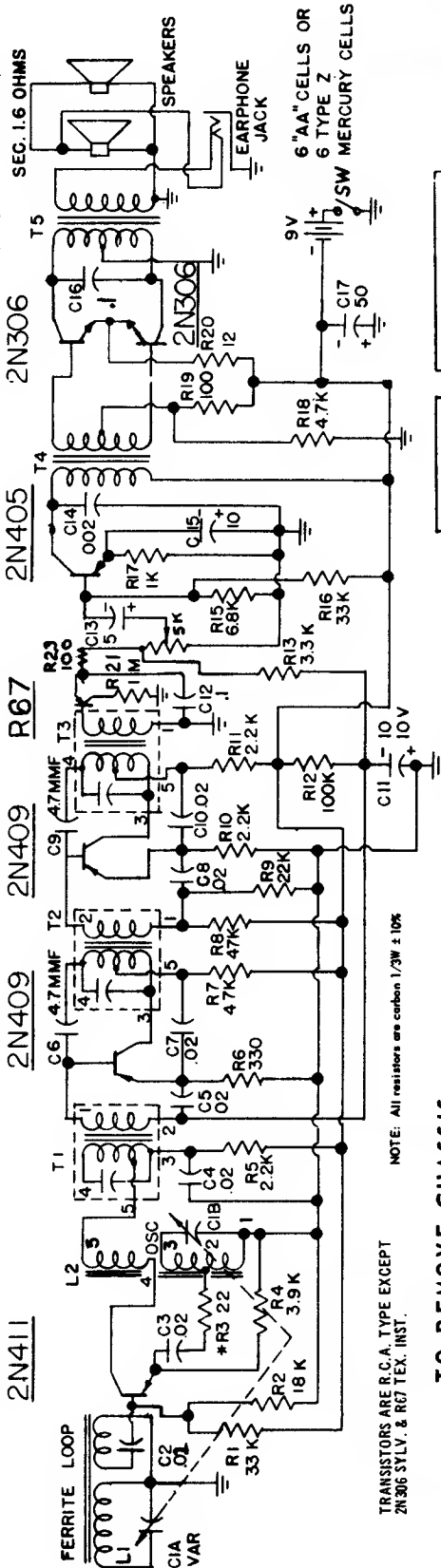

TRANSISTORS ARE R.C.A. TYPE EXCEPT 2N306 SILV. & R67 TEX. INST.

TO REMOVE CHASSIS

1. Remove volume control knob by pulling away from case.
2. Move handle to rear.
3. Release spring clips on each side of cabinet and remove back.
4. Remove battery holder.
5. Unscrew the four chassis corner mounting screws
6. Remove one screw holding volume control bracket.
7. Slide down to bottom of case and out to clear tuning knob from case.

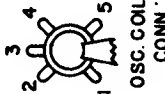

ALIGNMENT

Function	Generator Frequency	Dummy Antenna	Generator Conn.	Adjust for Max. Output	Remarks
1. I.F.	455KC	.1 Mfd Condenser in series with Gen. Lead	On Converter Base	T1, T2, T3	
2. Osc. Trimmer	1620KC		*Test Loop C1-B	Variable Condenser Set for Minimum capacity	
3. Osc. Slug	540KC		*Test Loop L-2 Slug	Variable Condenser Set For Maximum Capacity	
4. Ant. Trimmer	1400KC		*Test Loop C1-A	Tune 1400 Kc on Variable Condenser	

* Standard Horizontal Loop Model 1150 or 3 turns of wire about 6" diameter placed one foot from set.

AM IF 455 KC.
FM IF 10.7 MC.

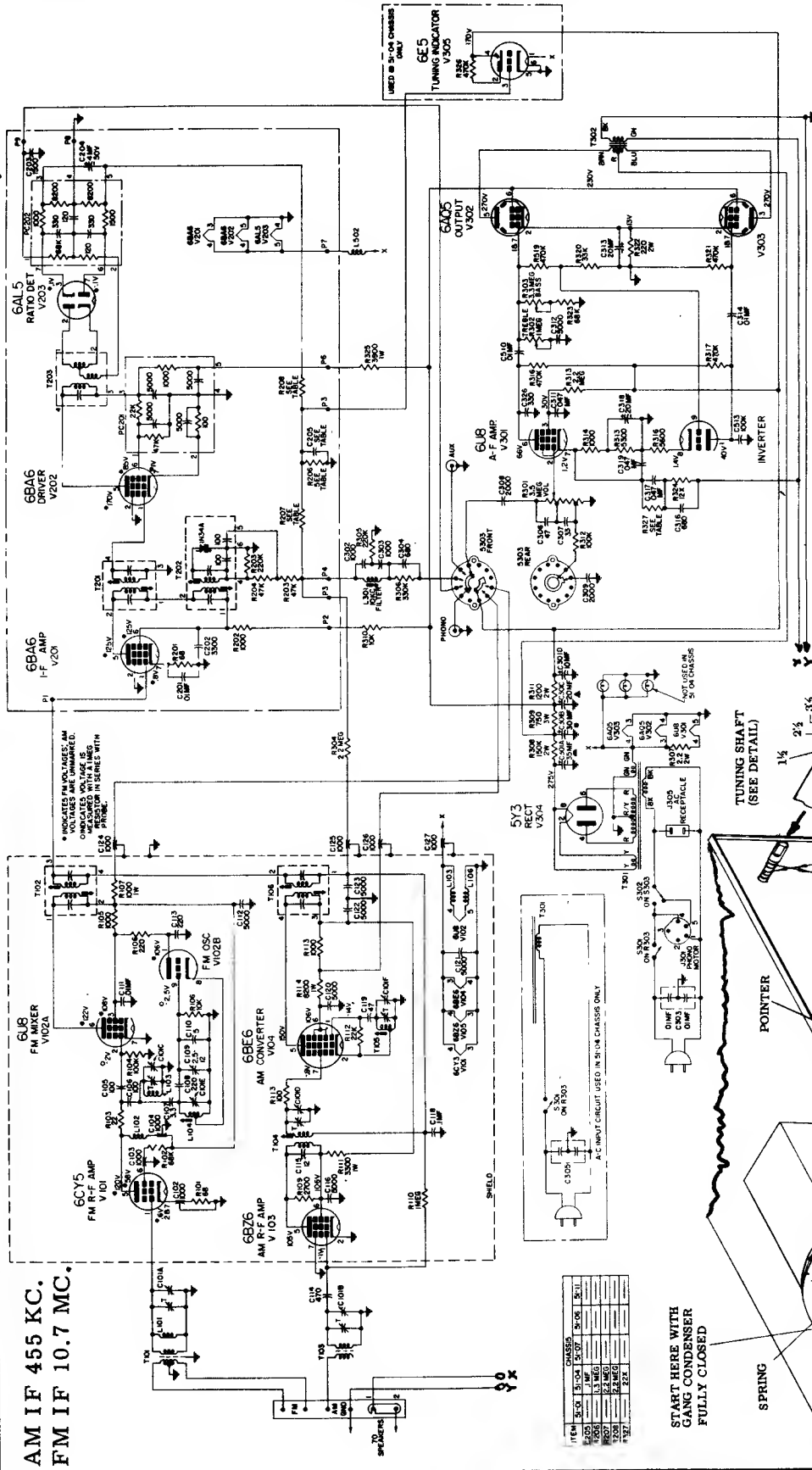

ITEM	QTY	TYPE	DESCRIPTION
1004	312	5107	500K
1005	13	5107	500K
1006	13	5107	500K
1007	13	5107	500K
1008	13	5107	500K
1009	13	5107	500K
1010	13	5107	500K
1011	13	5107	500K
1012	13	5107	500K
1013	13	5107	500K
1014	13	5107	500K
1015	13	5107	500K
1016	13	5107	500K
1017	13	5107	500K
1018	13	5107	500K
1019	13	5107	500K
1020	13	5107	500K
1021	13	5107	500K
1022	13	5107	500K
1023	13	5107	500K
1024	13	5107	500K
1025	13	5107	500K
1026	13	5107	500K
1027	13	5107	500K
1028	13	5107	500K
1029	13	5107	500K
1030	13	5107	500K
1031	13	5107	500K
1032	13	5107	500K
1033	13	5107	500K
1034	13	5107	500K
1035	13	5107	500K
1036	13	5107	500K
1037	13	5107	500K
1038	13	5107	500K
1039	13	5107	500K
1040	13	5107	500K
1041	13	5107	500K
1042	13	5107	500K
1043	13	5107	500K
1044	13	5107	500K
1045	13	5107	500K
1046	13	5107	500K
1047	13	5107	500K
1048	13	5107	500K
1049	13	5107	500K
1050	13	5107	500K

START HERE WITH GANG CONDENSER FULLY CLOSED

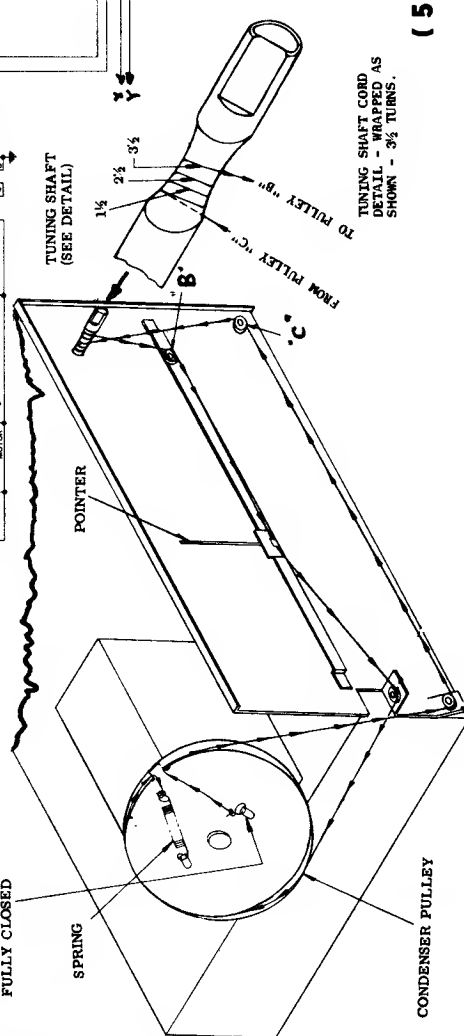

Spartan

(51-01, 51-04, 51-07, 51-09, 51-11)

TUNING SHAFT CORD PULL - 1/2 TURN AS SHOWN - 3/2 TURNS.

SYLVANIA ELECTRIC PRODUCTS

CHASSIS 1-609-7
MODELS: SC03 SERIES

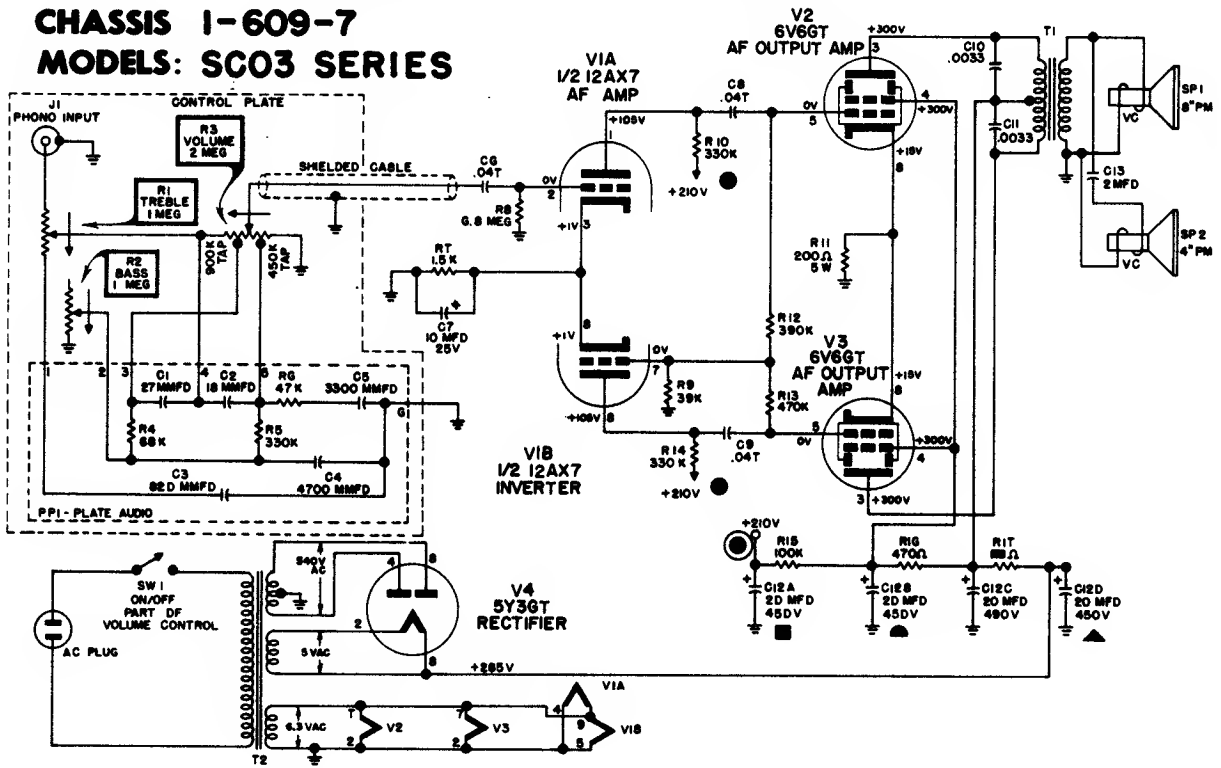

CHASSIS: 1-639-1
MODELS: 4312 SERIES

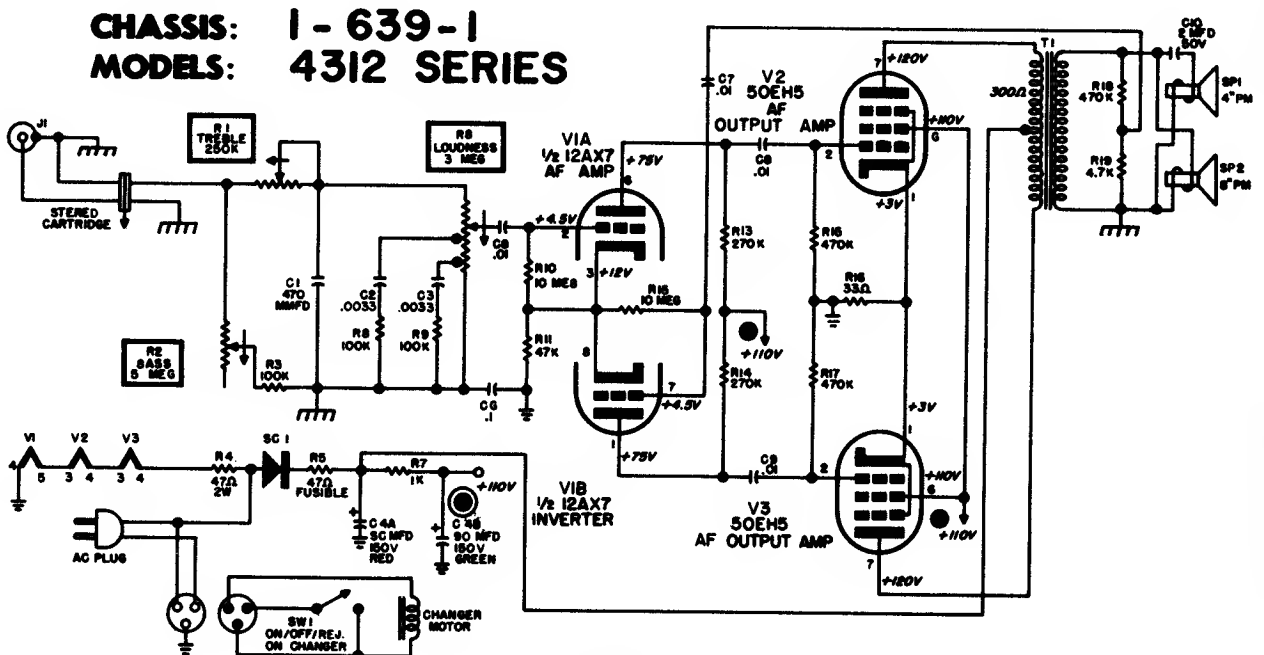

SCHEMATIC NOTES:

1. VOLTAGES SHOWN ARE AVERAGE READINGS MEASURED TO NEGATIVE "B" WITH NO SIGNAL INPUT. VARIATIONS MAY BE NOTED DUE TO NORMAL PRODUCTION TOLERANCES.
2. AC POWER SOURCE - 117V 60W "VARIAC REGULATED".
3. VOLTAGE SOURCE IS INDICATED BY ENCIRCLED SYMBOL Ⓢ; CORRESPONDING SYMBOL WITHOUT CIRCLE Ⓢ INDICATES VOLTAGE TIE POINTS.
4. --- DESIGNATES CHASSIS GROUND.
5. \ominus DESIGNATES NEGATIVE "B".

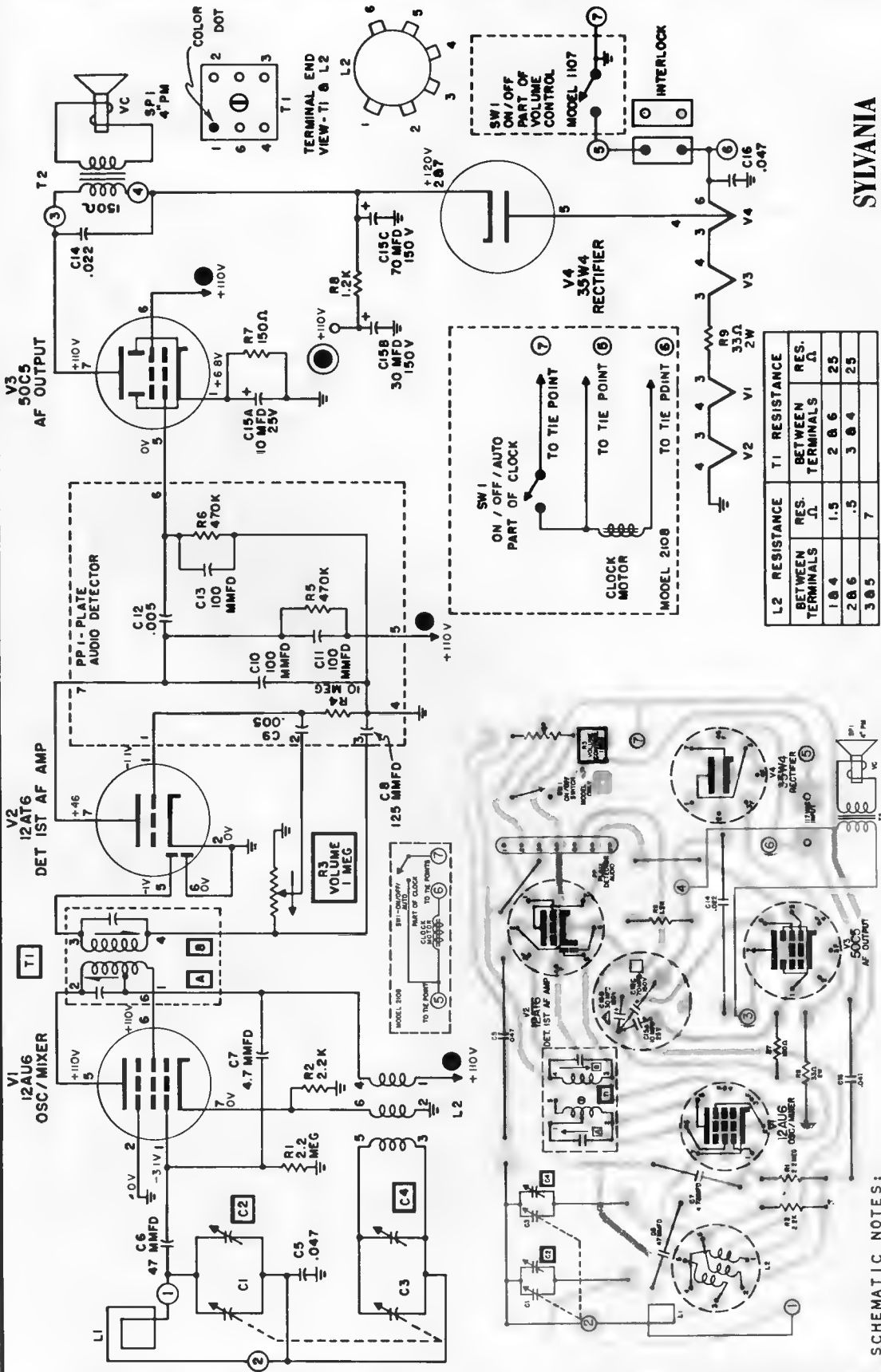

SCHEMATIC NOTES:
 COIL AND TRANSFORMER RESISTANCES ARE AVERAGE VALUES AND ARE TAKEN WITH COMPONENT CDNNNECTED IN THE CIRCUIT.
 INTERMEDIATE FREQUENCY 455KC.
 ENCIRCLED NUMBERS CORRESPOND WITH TIE POINTS ON PRINTED BOARD.
 VOLTAGE SOURCE IS INDICATED BY ENCIRCLED SYMBOL ⊕; CORRESPONDING SYMBOL WITHOUT CIRCLE • INDICATES VOLTAGE TIE POINTS.
 ⊖ DESIGNATES NEGATIVE "B".

SYLVANIA
 RADIO & TELEVISION

CHASSIS: 1-629-1,-2
MODELS: 1107 & 2108

SYLVANIA
RADIO & TELEVISION

CHASSIS: 1-630-1,-2
MODELS: 1108 & 2109

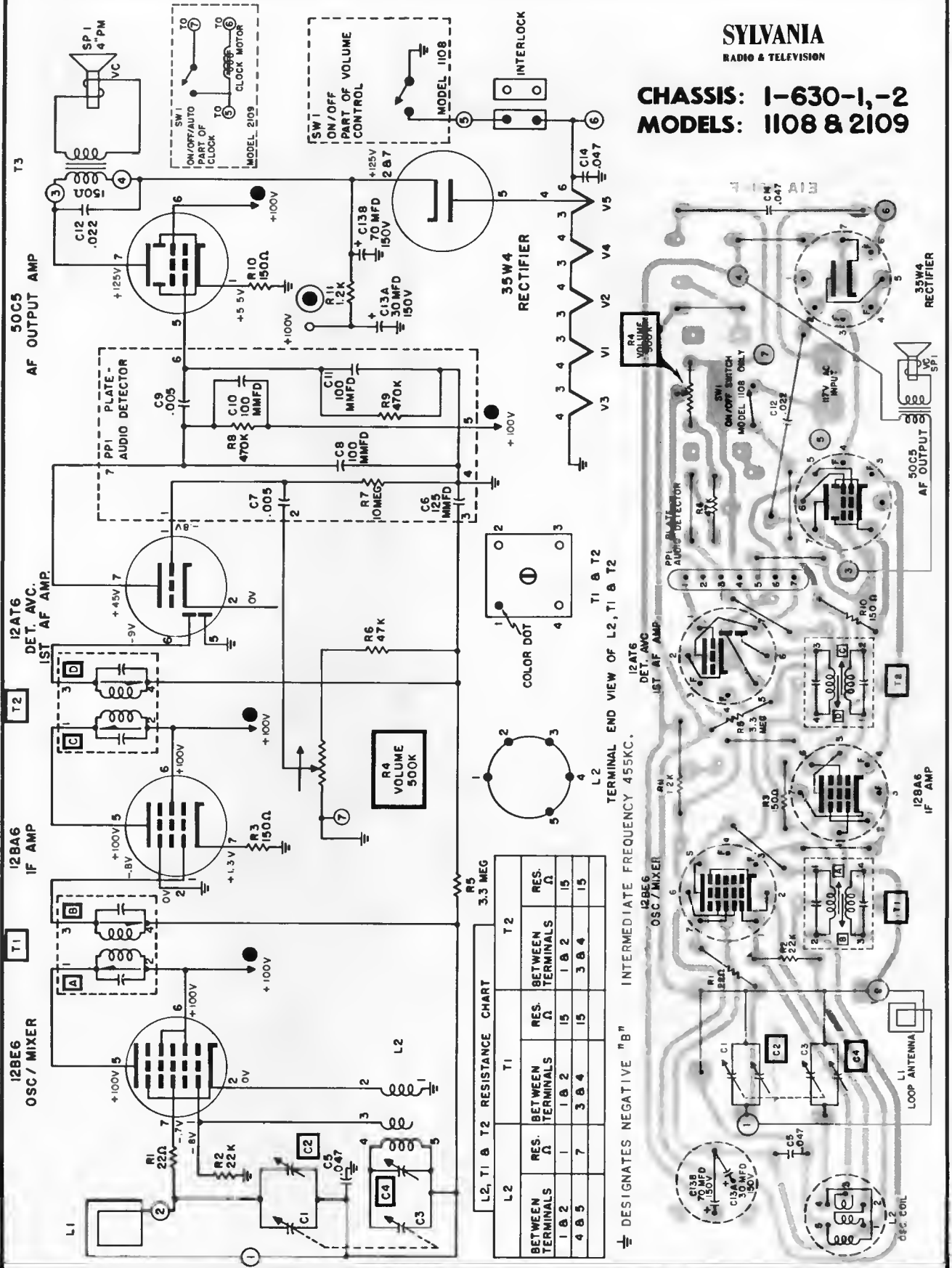

SYLVANIA Electric Products
Chassis 1-631-1, Model 1303

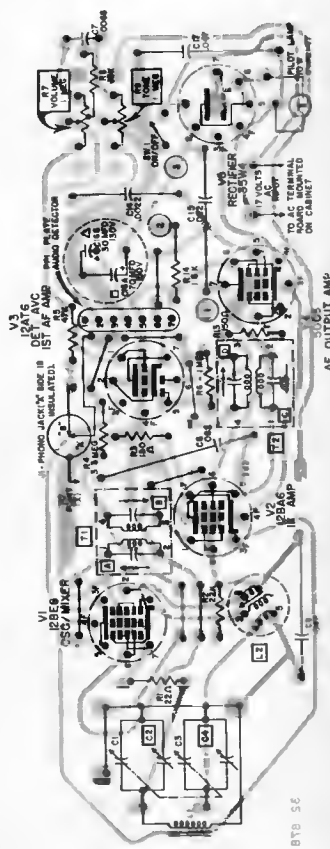
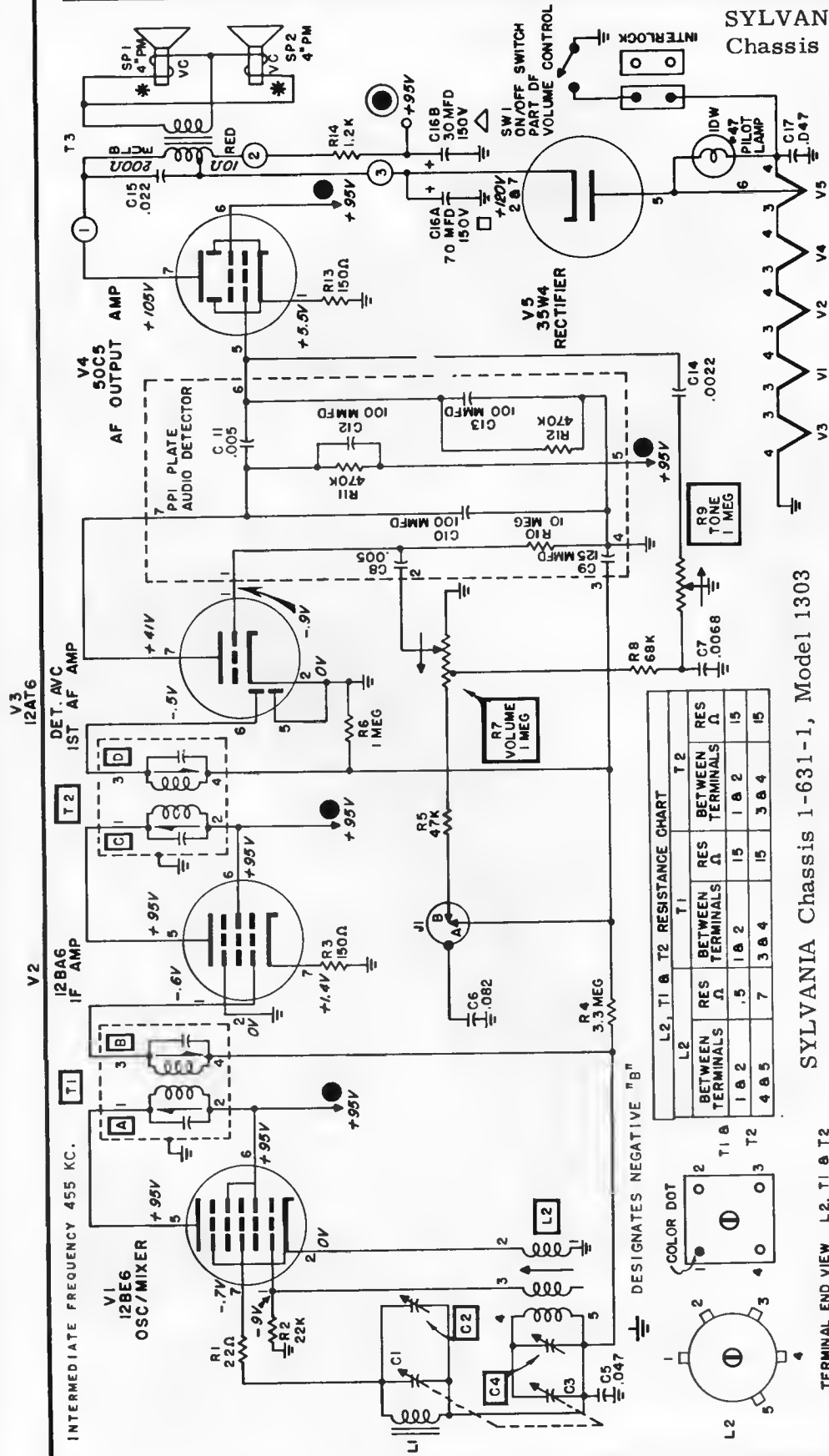

L2, T1 & T2 RESISTANCE CHART

L2	T1		T2	
	BETWEEN TERMINALS	RES Ω	BETWEEN TERMINALS	RES Ω
1 & 2	15	15	15	15
1 & 3	7	3 & 4	15	3 & 4
4 & 5				15

SYLVANIA Chassis 1-631-1, Model 1303

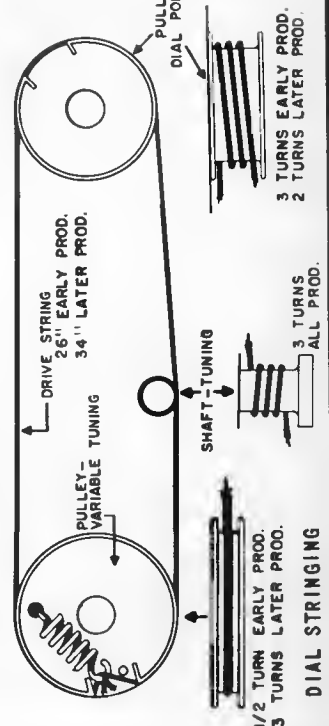

TERMINAL END VIEW L2, T1 & T2

SYLVANIA

CHASSIS: 1-632-1,-2
 MODELS: 1304 & 2305

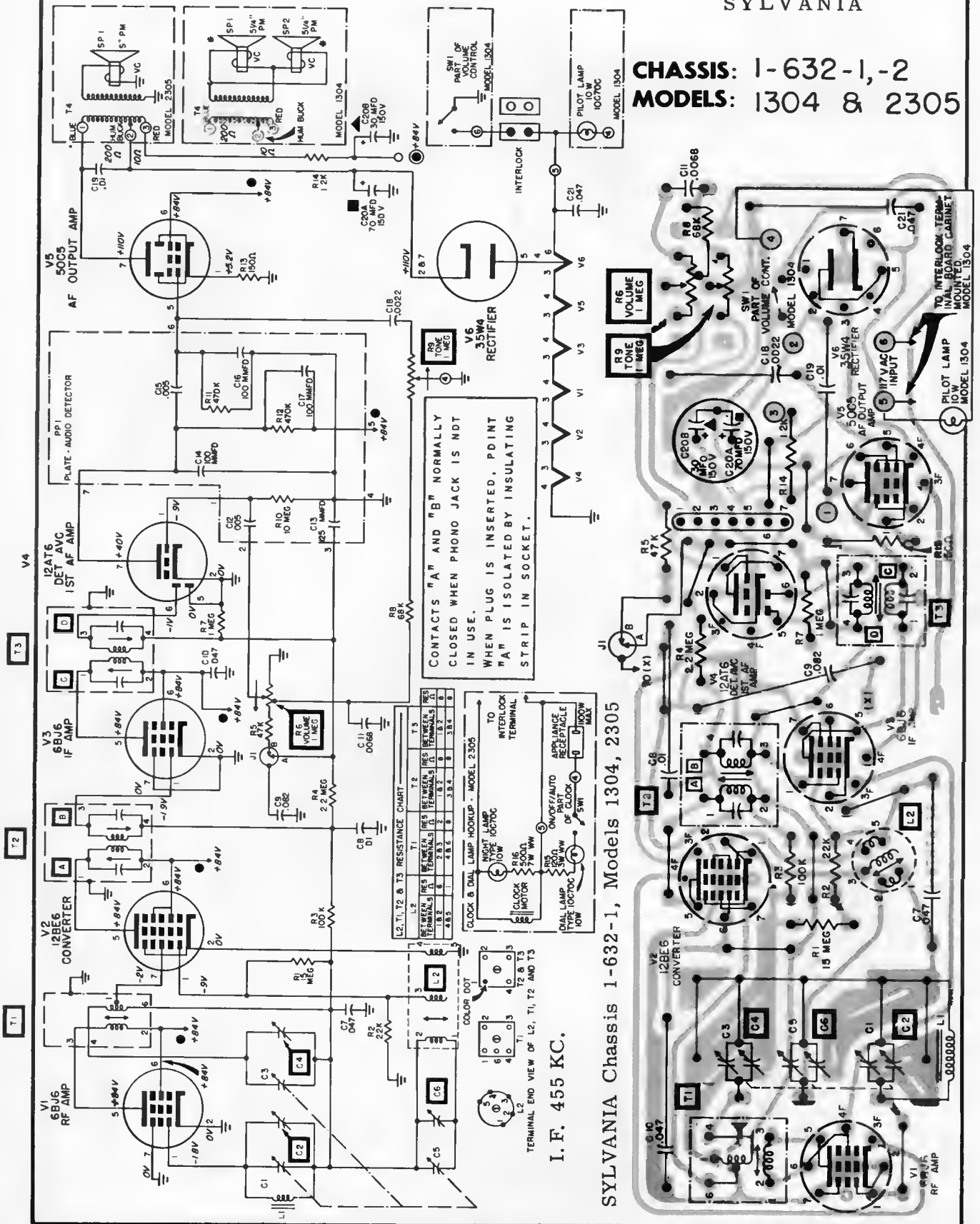



SYLVANIA Chassis 1-632-1, Models 1304, 2305

I. F. 455 KC.

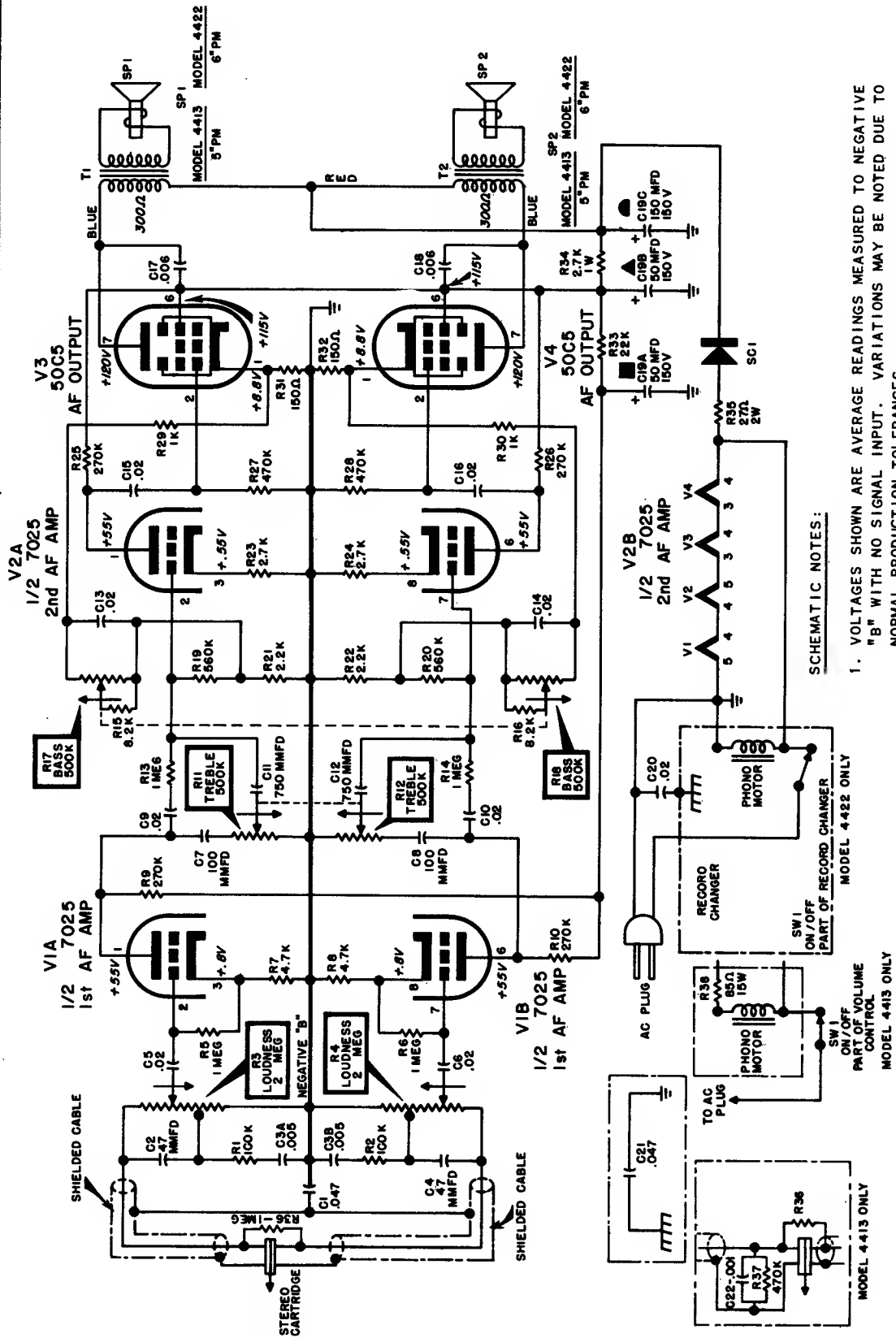
SYLVANIA ELECTRIC PRODUCTS Chassis 1-645-1, Models 4413, 4422



SCHEMATIC NOTES:

1. VOLTAGES SHOWN ARE AVERAGE READINGS MEASURED TO NEGATIVE "B" WITH NO SIGNAL INPUT. VARIATIONS MAY BE NOTED DUE TO NORMAL PRODUCTION TOLERANCES.
2. AC POWER SOURCE - 117V 60⁰ VARIAC REGULATED*
3.  DESIGNATES CHASSIS GROUND.
4.  DESIGNATES NEGATIVE "B".

SYLVANIA ELECTRIC PRODUCTS

CHASSIS: 1-645-1

MODELS: 4413 & 4422

TRAVLER MODEL 48-314

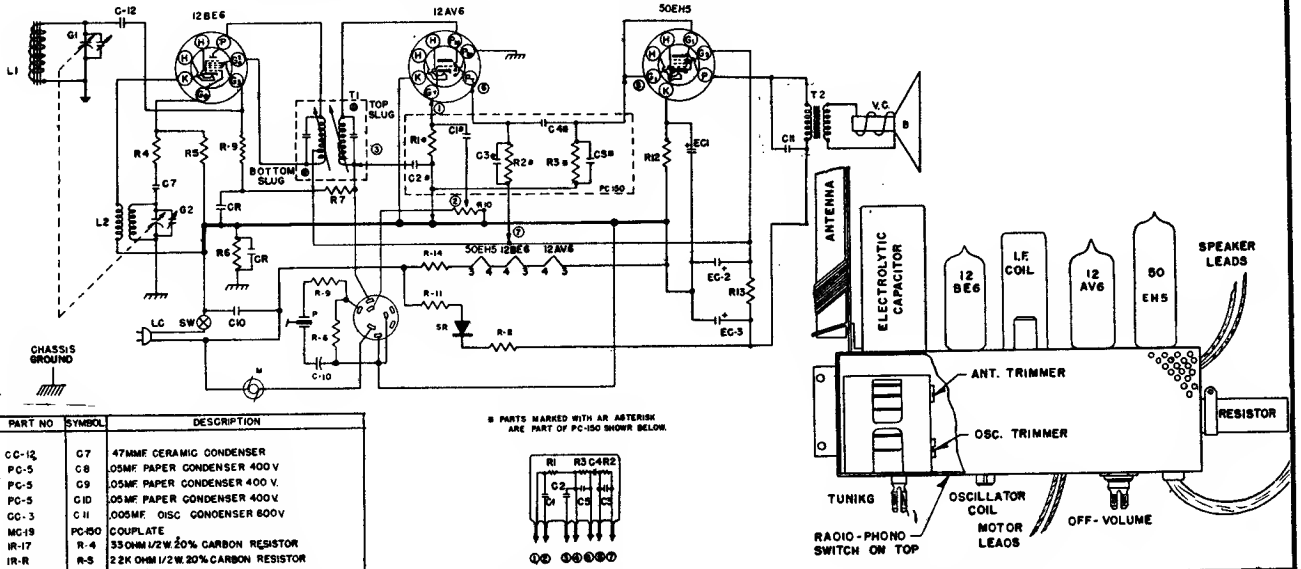

PART NO	SYMBOL	DESCRIPTION
CC-12	G7	47MMF CERAMIC CONDENSER
PC-5	C8	005MF PAPER CONDENSER 400V
PC-5	C9	005MF PAPER CONDENSER 400V
PC-5	C10	005MF PAPER CONDENSER 400V
CC-3	C11	0005MF DISC CONDENSER 600V
MG-19	PC-150	COUPLATE
IR-17	R-4	330HM 1/2W 20% CARBON RESISTOR
IR-18	R-5	22K OHM 1/2W 20% CARBON RESISTOR
IR-20	R-6	250K OHM 1/2W 20% CARBON RESISTOR
IR-23	R-7	3.3MEG OHM 1/2W 20% CARBON RESISTOR
IR-41	R-8	47 OHM 1W 10% CARBON RESISTOR
IR-41	R-9	1MEG OHM 1/2W 20% CARBON RESISTOR
CC-33	C-12	220MMFD 350V 20% CERAMIC TUB COND.
VC-54	R-10	1MEG OHM VOLUME CONTROL
IR-14	R-11	330HM 1/2W 20% CARBON RESISTOR
IR-14	R-12	150 OHM 1/2W 20% CARBON RESISTOR
IR-25	R-13	2200 OHM 1W 10% CARBON RESISTOR
EG-71A	EG-1	20MF-150VDC ELECTROLYTIC CONDENSER
EG-71A	EG-2	30MF-150VDC ELECTROLYTIC CONDENSER
EG-71A	EG-3	40MF-150VDC ELECTROLYTIC CONDENSER
GO-1	LC	A.C. LINE CORD
GC-15	G1	ANT SECTION-WITH TRIMMER GANG
GC-15	G2	OSC SECTION-WITH TRIMMER CONDENSER
LL-55	L1	FERRAMIC ROD ANTENNA COIL
LD-28	L2	OSCILLATOR COIL
LI-12	T1	455 KC TAPPED PRIMARY-IF COIL
SW	S	SPST SWITCH(PART OF VOLUME CONTROL)
T2	T2	OUTPUT TRANSFORMER P.M.
VC	VC	VOICE COIL WINDING SPEAKER
SPK-22-C	S	SPEAKER

* PARTS MARKED WITH AN ASTERISK ARE PART OF PC-150 SHOWN BELOW.

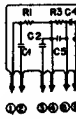

COMPONENTS & VALUES OF PC-150

- C1-2000MMF
- C2-220MMF
- C3-250MMF
- C4-5000MMF
- R1-6.8MEG OHM
- R2-47MEG OHM
- R3-47MEG OHM

PART NO	SYMBOL	DESCRIPTION
3-M-13	M	110 V. MOTOR-3 SPEED
PU-34	P	PICKUP UP ARM 8SR-TC-R-M CARTRIDGE
WR-47	R-14	250 OHM-10 W. 5% WIREWOUND
SR-3	SR	66 ML. RECTIFIER

I.F. 455 KC.

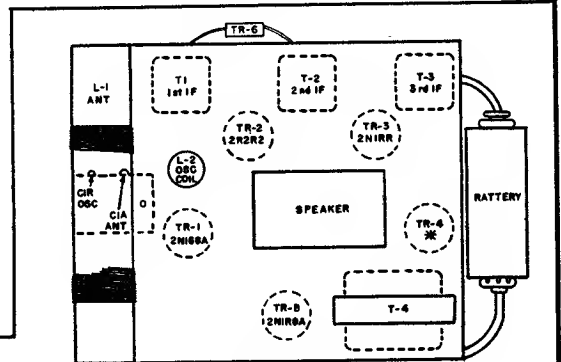

NOTE: REPLACE TRANSISTORS ONLY WITH TYPE FOUND IN RECEIVER TRANSISTOR PART NUMBER NO. SC-12 OR GEN. ELEC. 2N107

MODELS-TR-280-A, 281-A, 282-A, 283-A

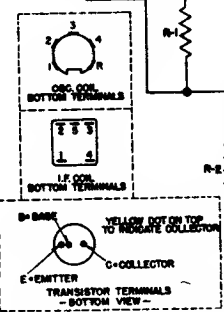
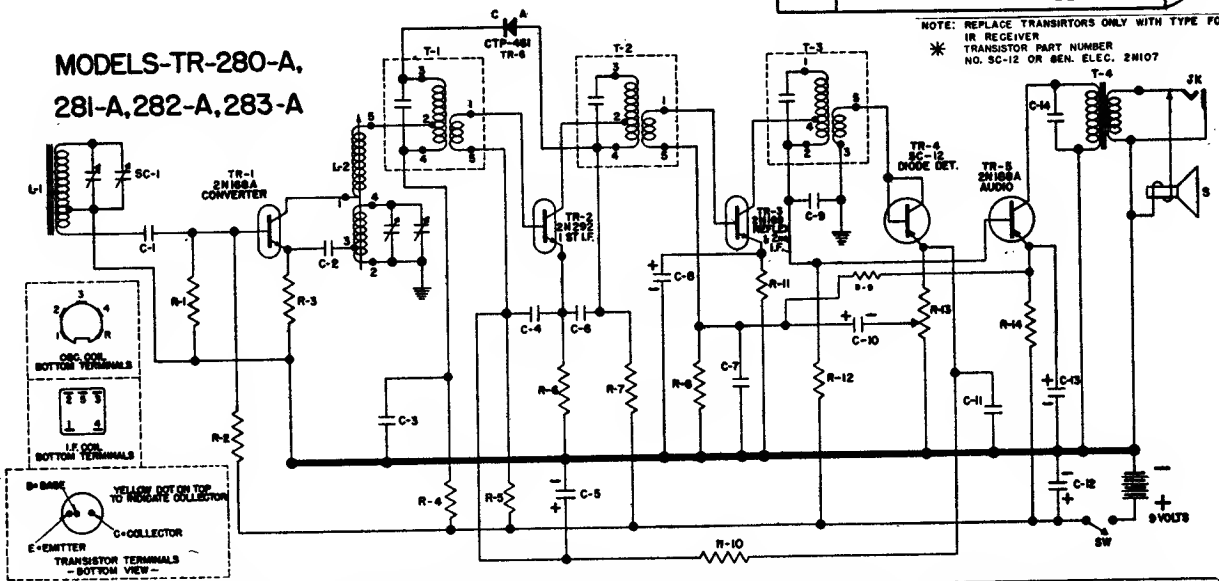

PART NO	SYMBOL	DESCRIPTION	PART NO	SYMBOL	DESCRIPTION	PART NO	SYMBOL	DESCRIPTION
CC-55	C-1	D2 CERAMIC DISC	TR-54	R-1	10K OHMS 1/2W 10% CARBON RESISTOR	LI-22	T-1	1ST STAGE LF TRANSFORMER
CC-55	C-2	0.1 MFD. CERAMIC DISC	TR-54	R-2	55K	LI-22	T-2	2ND STAGE LF TRANSFORMER
CC-54	C-3	0.1 MFD. CERAMIC DISC	TR-29	R-3	1500	AT-33	T-3	OUTPUT TRANSFORMER
CC-54	C-4	0.1 MFD. CERAMIC DISC	IR-199	R-4	470	TR-1	TR-1	2N188A CONVERTER TRANSISTOR
CC-56	C-5	0.05 MFD. ELECTROLYTIC COND.	IR-3	R-5	82K	TR-2	TR-2	2N222 1ST IF
CC-56	C-6	0.05 MFD. ELECTROLYTIC COND.	IR-189	R-6	330	SC-9	SC-9	2N188A 2ND STAGE
CC-45	C-7	0.05 MFD. ELECTROLYTIC COND.	IR-158	R-7	4700	SC-10	SC-10	2N188A 3RD STAGE
CC-45	C-8	0.05 MFD. ELECTROLYTIC COND.	IR-158	R-8	4700	TR-3	TR-3	2N188A AUDIO TRANSISTOR
CC-45	C-9	0.05 MFD. ELECTROLYTIC COND.	IR-158	R-9	4700	TR-4	TR-4	2N188A OUTPUT TRANSISTOR
CC-45	C-10	0.05 MFD. ELECTROLYTIC COND.	IR-158	R-10	3300	CTP-44	CTP-44	44K OHM-GETTERLESS DIODE
CC-45	C-11	0.05 MFD. ELECTROLYTIC COND.	IR-158	R-11	470	SC-11	SC-11	2N188A 4TH STAGE
CC-45	C-12	0.05 MFD. ELECTROLYTIC COND.	IR-158	R-12	470	TR-5	TR-5	2N188A 5TH STAGE
CC-45	C-13	0.05 MFD. ELECTROLYTIC COND.	IR-158	R-13	1500	TR-6	TR-6	2N188A 6TH STAGE
CC-45	C-14	0.05 MFD. ELECTROLYTIC COND.	IR-158	R-14	1500	SW	SW	SWITCH ON VOLUME CONTROL
CC-45	C-15	0.05 MFD. ELECTROLYTIC COND.	IR-158	R-15	470	SPK-32	R	P.M. SPEAKER
CC-45	C-16	0.05 MFD. ELECTROLYTIC COND.	IR-158	R-16	470	LI-45	L-1	1ST STAGE LF TRANSFORMER
CC-45	C-17	0.05 MFD. ELECTROLYTIC COND.	IR-158	R-17	470	LI-45	L-2	2ND STAGE LF TRANSFORMER
CC-45	C-18	0.05 MFD. ELECTROLYTIC COND.	IR-158	R-18	470	LI-45	L-3	3RD STAGE LF TRANSFORMER
CC-45	C-19	0.05 MFD. ELECTROLYTIC COND.	IR-158	R-19	470	SC-12	SC-12	2N188A 7TH STAGE
CC-45	C-20	0.05 MFD. ELECTROLYTIC COND.	IR-158	R-20	470	SC-13	SC-13	2N188A 8TH STAGE
CC-45	C-21	0.05 MFD. ELECTROLYTIC COND.	IR-158	R-21	470	SC-14	SC-14	2N188A 9TH STAGE
CC-45	C-22	0.05 MFD. ELECTROLYTIC COND.	IR-158	R-22	470	SC-15	SC-15	2N188A 10TH STAGE
CC-45	C-23	0.05 MFD. ELECTROLYTIC COND.	IR-158	R-23	470	SC-16	SC-16	2N188A 11TH STAGE
CC-45	C-24	0.05 MFD. ELECTROLYTIC COND.	IR-158	R-24	470	SC-17	SC-17	2N188A 12TH STAGE

VOLUME R-19, MOST-OFTEN-NEEDED 1959 RADIO SERVICING INFORMATION

WEBCOR Models 1953, 1991, using AM Tuner 73X014-1, Amplifiers 14X278-1, -2

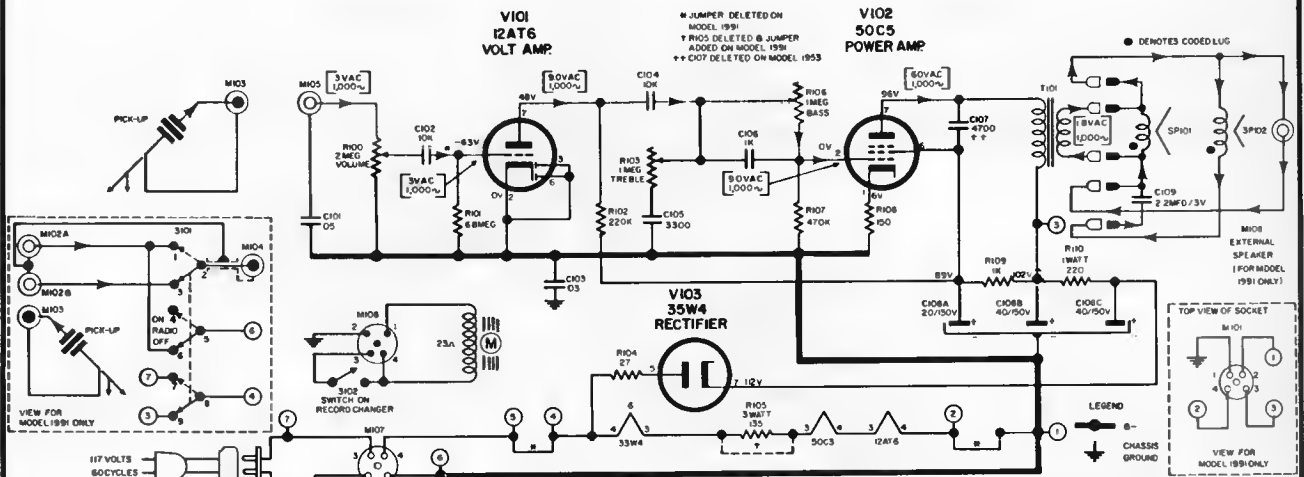

Circuit Diagram of 14X278-1 (1953) and 14X278-2 (1991) Amplifiers, Issue 1; and 73X014-1 (1991) AM Tuner, Issue 1.

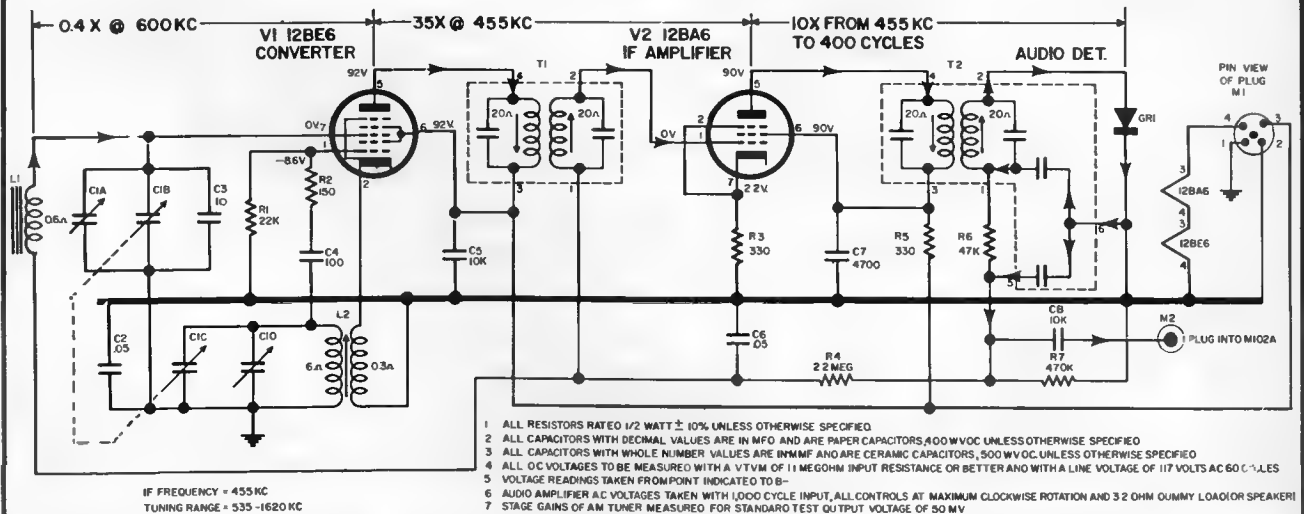

- 1 ALL RESISTORS RATED 1/2 WATT ± 10% UNLESS OTHERWISE SPECIFIED
- 2 ALL CAPACITORS WITH DECIMAL VALUES ARE IN MFD AND ARE PAPER CAPACITORS, 400 WVDC UNLESS OTHERWISE SPECIFIED
- 3 ALL CAPACITORS WITH WHOLE NUMBER VALUES ARE IN MMF AND ARE CERAMIC CAPACITORS, 500 WVDC UNLESS OTHERWISE SPECIFIED
- 4 ALL DC VOLTAGES TO BE MEASURED WITH A VTVM OF 11 MEGOHM INPUT RESISTANCE OR BETTER AND WITH A LINE VOLTAGE OF 117 VOLTS AC 60 CYCLES
- 5 VOLTAGE READINGS TAKEN FROM POINT INDICATED TO B-
- 6 AUDIO AMPLIFIER AC VOLTAGES TAKEN WITH 1000 CYCLE INPUT, ALL CONTROLS AT MAXIMUM CLOCKWISE ROTATION AND 32 OHM DUMMY LOAD (OR SPEAKER)
- 7 STAGE GAINS OF AM TUNER MEASURED FOR STANDARD TEST OUTPUT VOLTAGE OF 50 MV

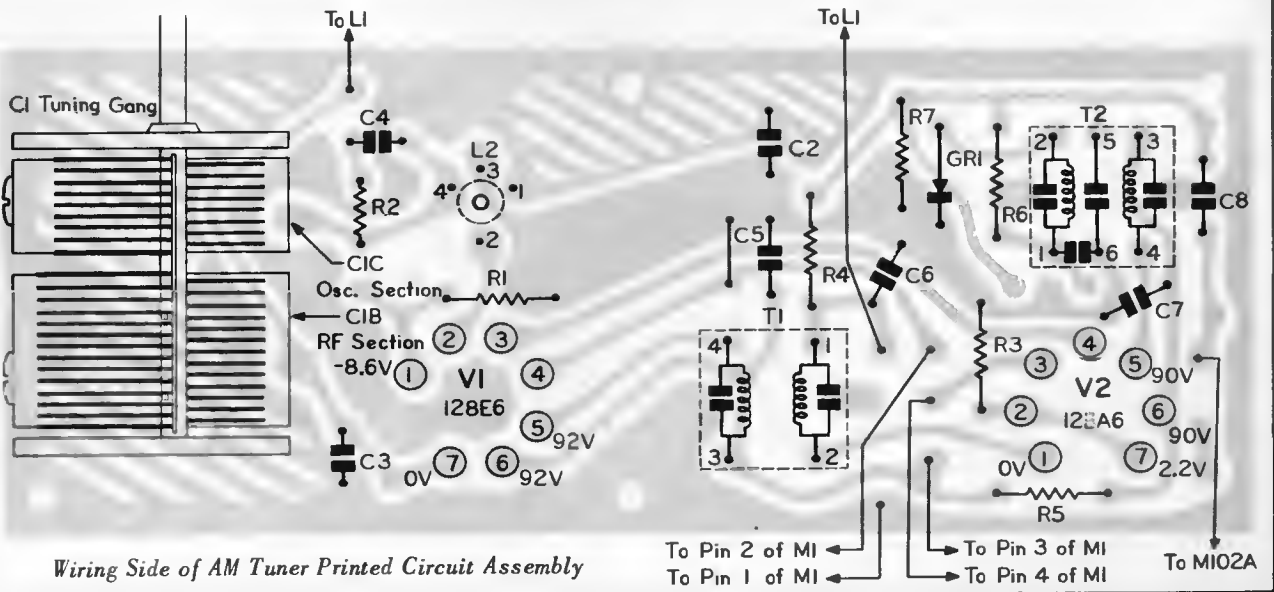

Wiring Side of AM Tuner Printed Circuit Assembly

WEBCOR Model 1954-1, using Amplifier 14X280-1

NEEDLE AND CARTRIDGE REPLACEMENT

If distortion or harshness of treble tones is encountered, it is probable that the cartridge and needle assembly (Webcor Part No. 21P586) requires replacement. To replace the cartridge and needle assembly, grasp the cartridge with thumb and forefinger and gently pull cartridge free.

CONNECTION JACKS

Stereo Output Jack: The Stereo Output Jack on the rear of the Holiday Coronet Cabinet makes it possible to connect a second sound system (amplifier and speakers) for Stereafonic reproduction. Webcor Model 4905 Companion Stereafonic Sound System is designed for use with the Holiday Coronet. When using the 4905 Sound System, connection to the Holiday Coronet is made with Stereo Connecting Cord No. 2933.

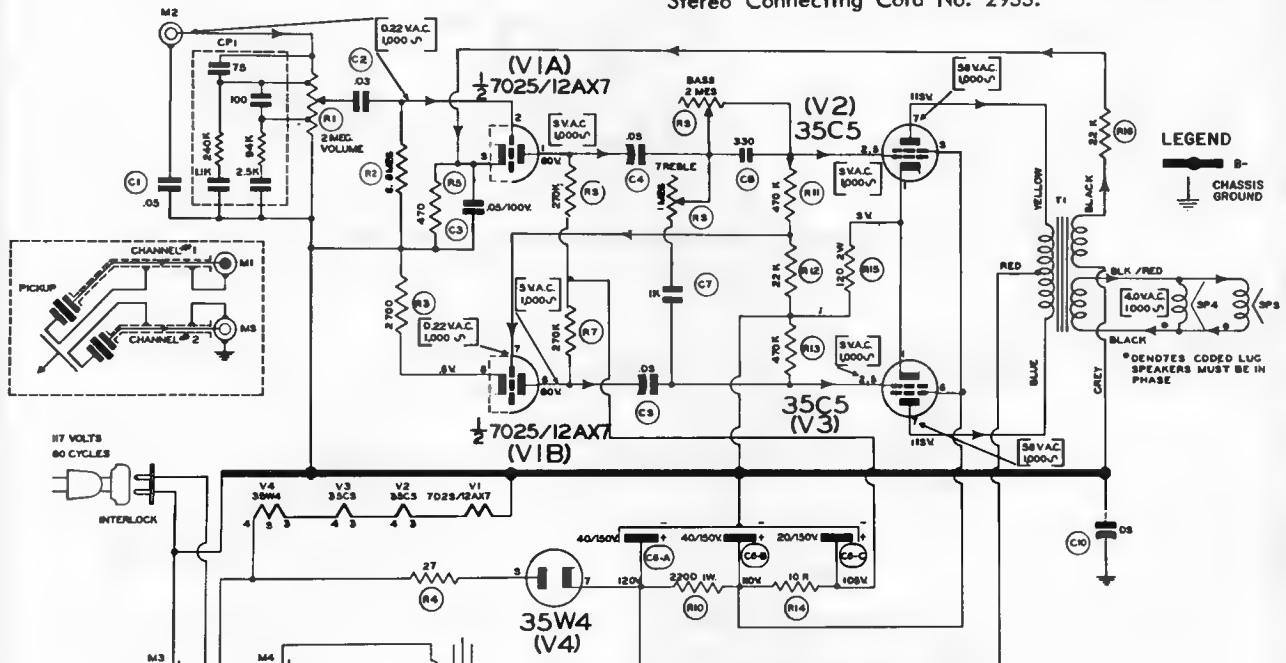

- NOTES:
 1 ALL RESISTORS 1/2 WATT 5% UNLESS OTHERWISE SPECIFIED
 2 ALL CAPACITORS WITH DECIMAL VALUES ARE IN MFD. AND ARE PAPER CONDENSERS, 400V WDC UNLESS OTHERWISE SPECIFIED
 3 ALL CAPACITORS WITH WHOLE NUMBER VALUES ARE IN MMF AND ARE CERAMIC CONDENSERS, 500V WDC UNLESS OTHERWISE SPECIFIED
 4 ALL DC VOLTAGES TO BE MEASURED WITH VTVM OF 11 MEGOHM INPUT RESISTANCE OR BETTER AND WITH A LINE VOLTAGE OF 117 VOLTS AC 60 CYCLES
 5 VOLTAGE READINGS TAKEN FROM POINT INDICATED TO B-
 6 AUDIO AMPLIFIER A.C. VOLTAGES TAKEN WITH 1000 CYCLE INPUT, ALL CONTROLS SET AT MAXIMUM COUNTERCLOCKWISE ROTATION AND 8 OHM DUMMY LOAD FOR SPEAKERS.

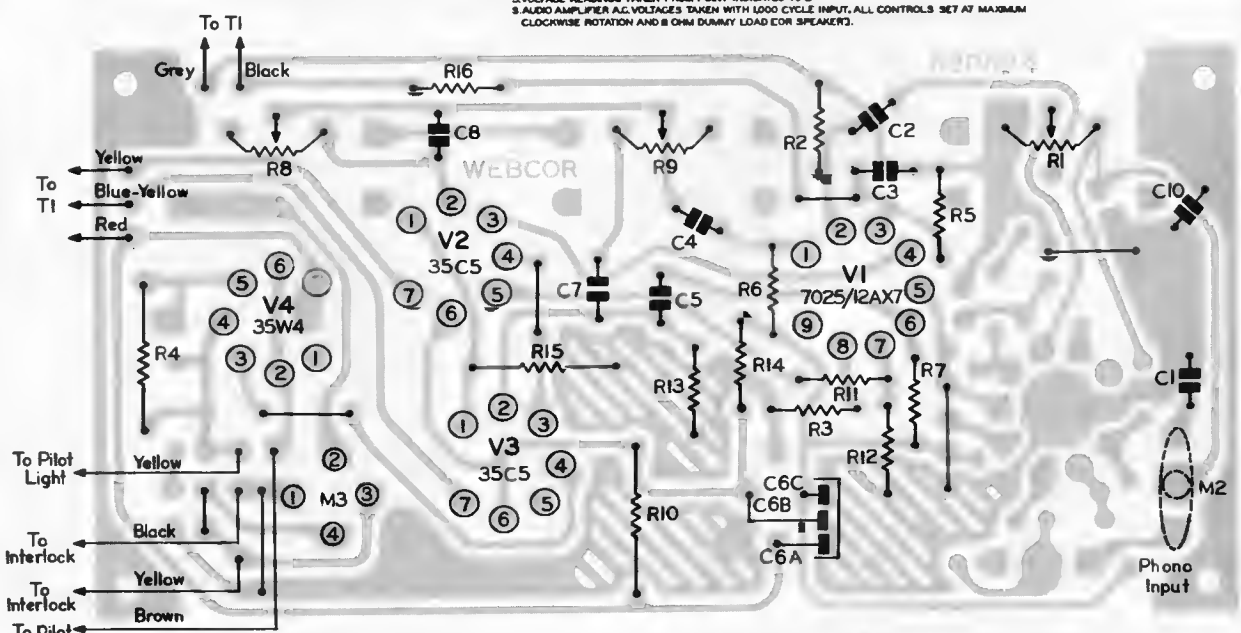

Wiring Side of 14X280-1 Amplifier Printed Wiring Assembly Showing Locations of All Component Connection Points.

VOLUME R-19, MOST-OFTEN-NEEDED 1959 RADIO SERVICING INFORMATION

WEBCOR Model 1956, using Amplifier 14X307

Model 1956 is a Stereo-Fidelity Fonograf that contains a 5", 3.2 ohm speaker for the right channel (Ch. 1) and a 5", 3.2 ohm speaker for the left channel (Ch. 2). Each speaker is mounted in the case side by side at a 7 degree angle for better separation of the right and left channels. In addition an External

Speaker Output Jack is incorporated. This jack permits connecting a 3.2 ohm External Speaker System to the fonograf if additional separation of the 2 channels is desired. When an External Speaker System is plugged into the External Speaker Output Jack, the left channel speaker in the fonograf is cut out.

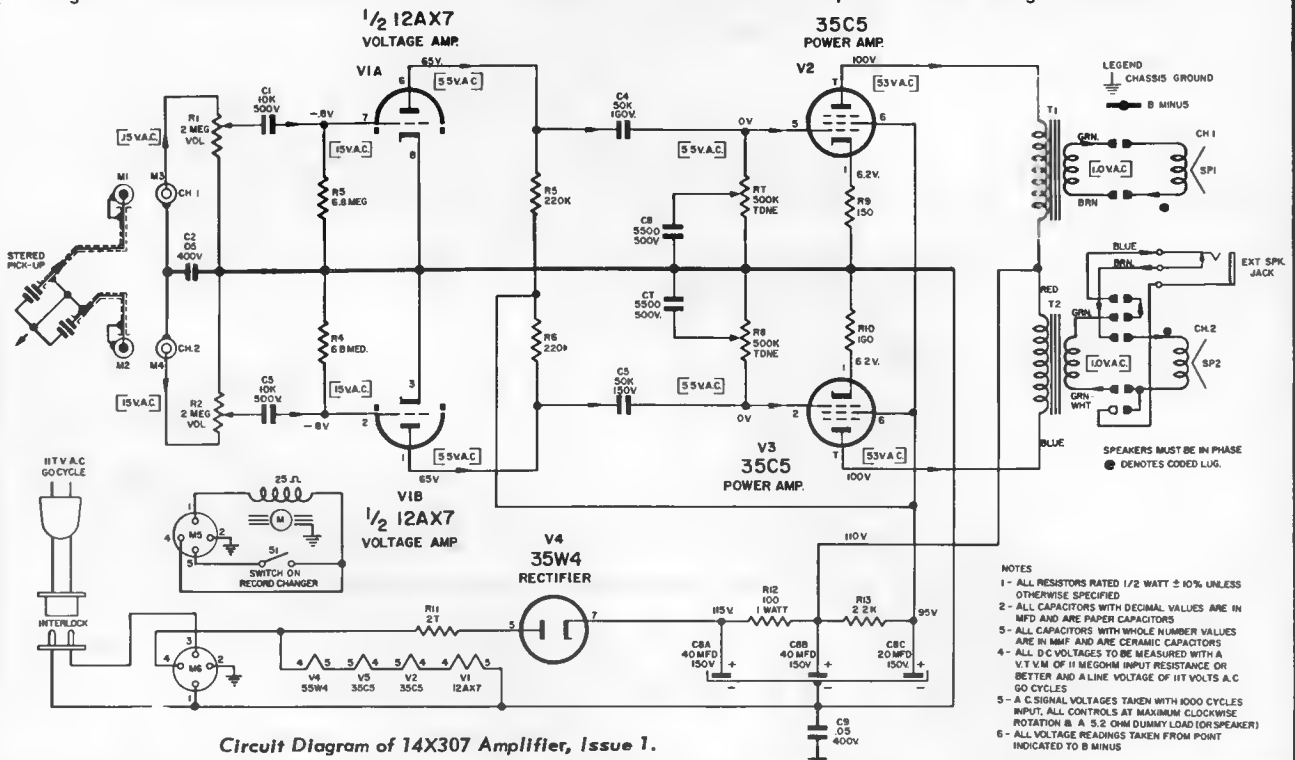

Circuit Diagram of 14X307 Amplifier, Issue 1.

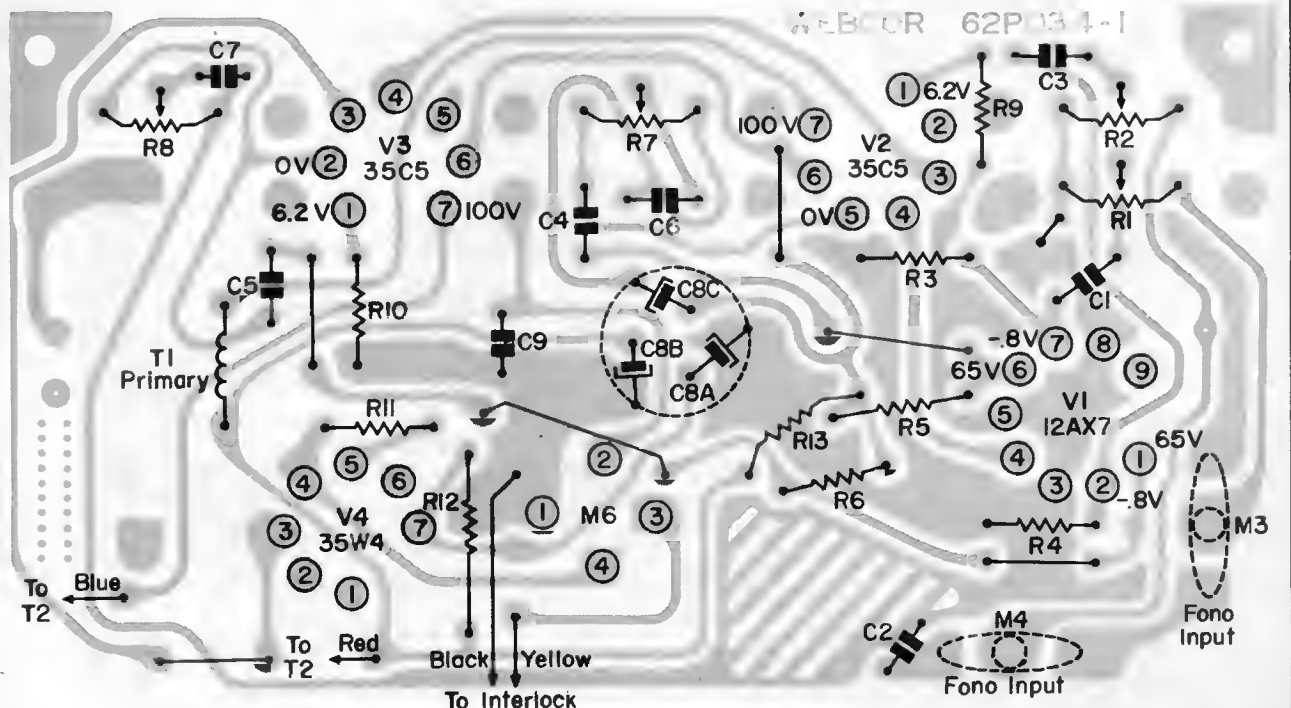

Wiring Side of 14X307 Amplifier Printed Circuit Assembly showing location of Component Connection Points.

WESTERN AUTO SUPPLY CO.

MODELS D2832A & D2834A D2832B & D2834B

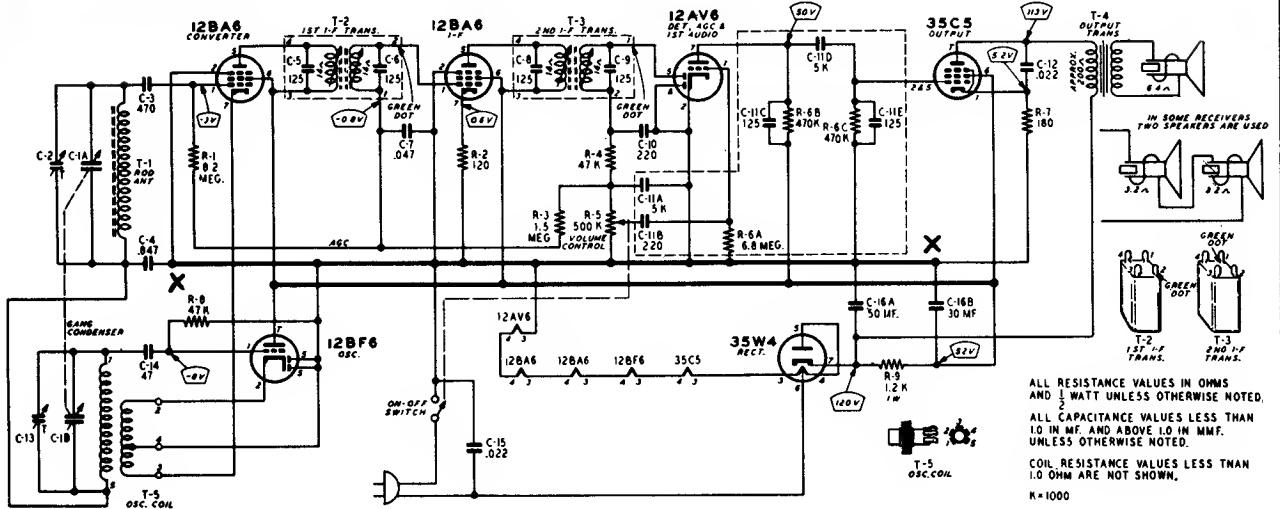

TUBE SOCKET VOLTAGES

Socket voltages are shown on the schematic diagram at the tube socket terminals. All voltages are between the socket terminal and "X" point. Voltages were taken with a vacuum tube voltmeter. Conditions of measurement are:

- Line voltage 117 Volts AC
- Signal Input None
- A Variation of $\pm 10\%$ is usually permissible.

SPECIFICATIONS

- 6 Tube Superheterodyne, including Rectifier Tube.
- Tuning Frequency Range 540 to 1600 KC
- Power Consumption 35 watts (At 117 volts AC)
- Power Output 1.3 watt maximum, 0.8 watt (10% distortion)
- Intermediate Frequency 455 KC
- Sensitivity 80 Microvolts Per Meter Average
- Selectivity 50 KC Wide at 1000 Times Signal
- Speaker 4" PM Dynamic

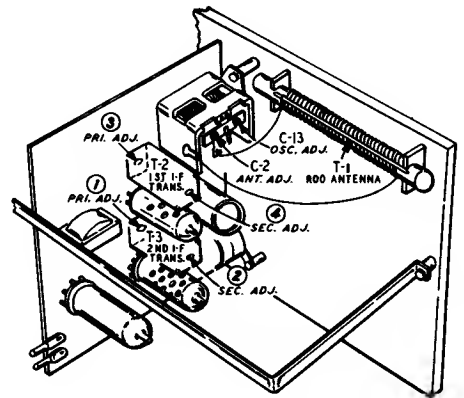

ALIGNMENT PROCEDURE

The following equipment is required for aligning; Signal Generator which will provide an accurately calibrated signal at the test frequencies as listed. Output Indicating Meter: Non-Metallic Screwdriver.

Dummy Antennas—.1 mf., 50 mmf.
Volume Control—Maximum All Adjustments.
Allow Chassis and Signal Generator to "Heat Up" for several Minutes.

FREQUENCY SETTING	SIGNAL GENERATOR ANTENNA CONNECTION	GROUND CONNECTION	DUMMY ANTENNA	GANG CONDENSER SETTING	ADJUST TUNING SLUGS (I.F.) AND TRIMMERS TO MAXIMUM
455 KC	Control Grid 12BA6-I.F. Prong No. 1	"X" Point	.1 mf.	Turn Rotor to full open	2nd I.F. Pri. (1) & Sec. (2)
455 KC	Control Grid 12BA6 Mixer Prong No. 1	"X" Point	.1 mf.	Turn Rotor to full open	1st I.F. Pri. (3) & Sec. (4) 2nd I.F. Pri. (1) & Sec. (2)
1620 KC	Control Grid 12BA6 Mixer Prong No. 1	"X" Point	.1 mf.	Turn Rotor to full open	Oscillator (C-13)
1400 KC	Std. Loop Connected to Signal Generator			Tune Receiver to 1400 KC.	Antenna (C-2) Trimmer

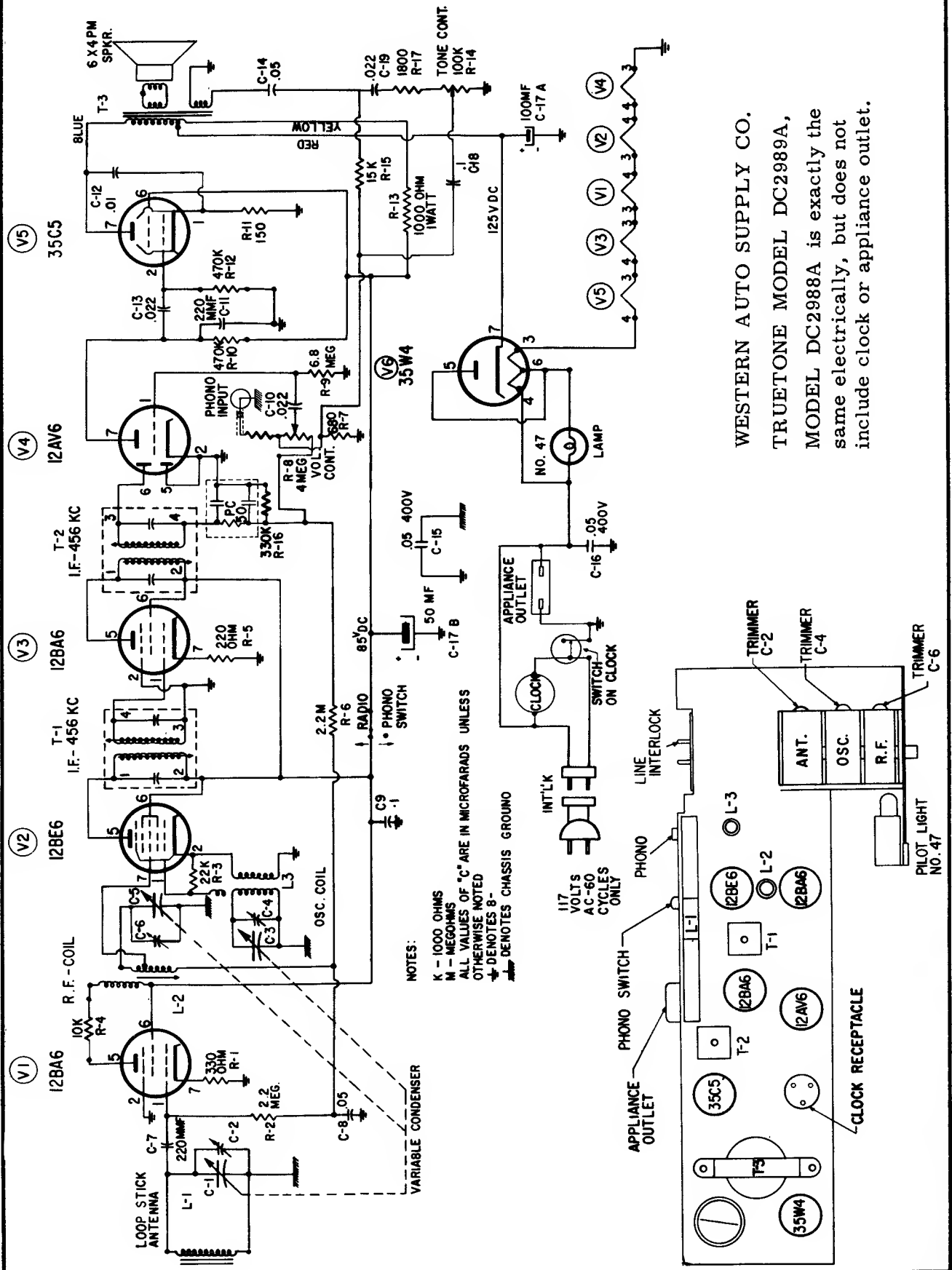

WESTERN AUTO SUPPLY CO.
 TRUETONE MODEL DC2989A,
 MODEL DC2988A is exactly the
 same electrically, but does not
 include clock or appliance outlet.

Westinghouse

MODELS H-629T4A, H-630T4A, H-631T4A,
CHASSIS V-2239-7

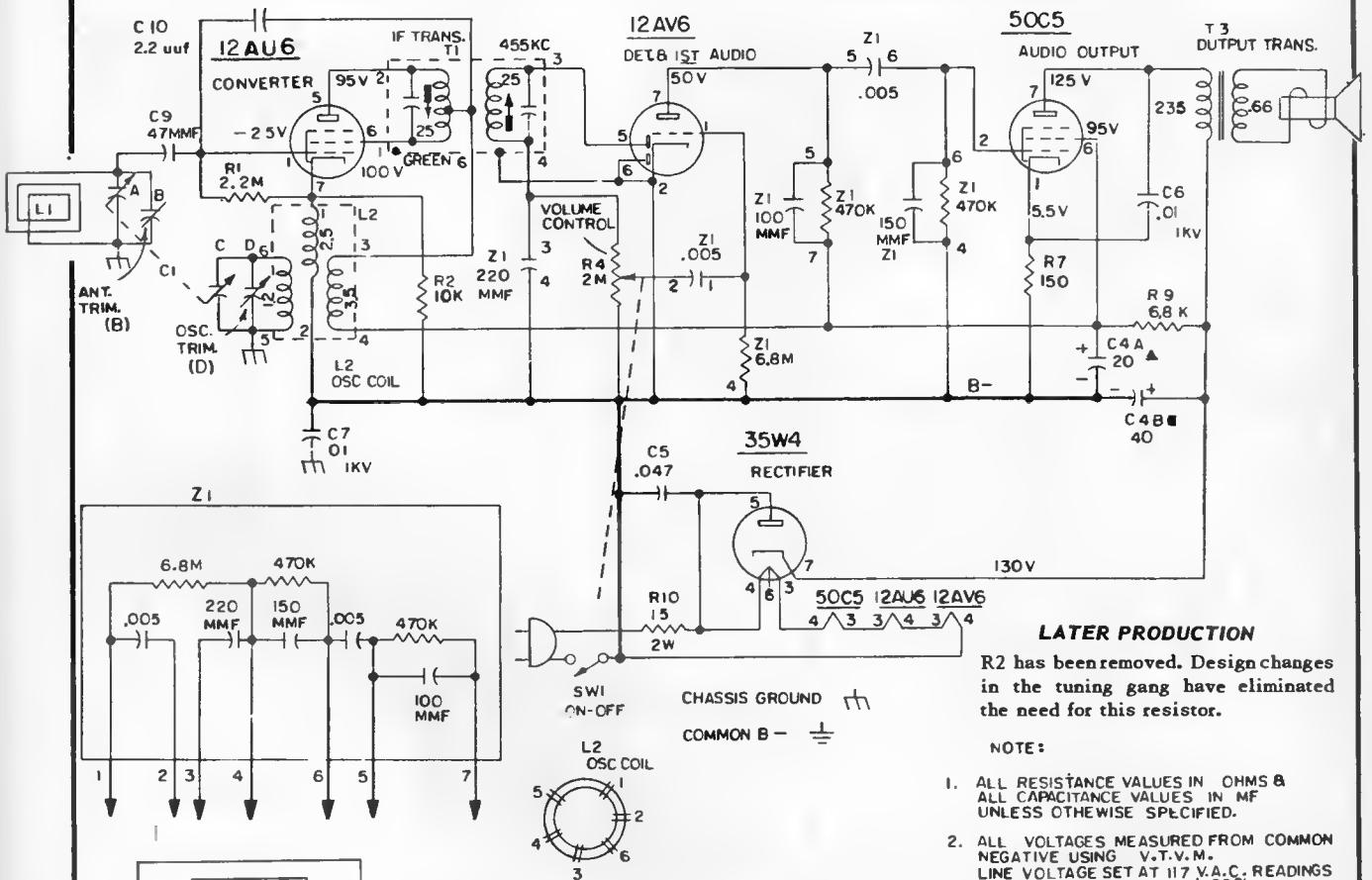

LATER PRODUCTION

R2 has been removed. Design changes in the tuning gang have eliminated the need for this resistor.

NOTE:

1. ALL RESISTANCE VALUES IN OHMS & ALL CAPACITANCE VALUES IN MF UNLESS OTHERWISE SPECIFIED.
2. ALL VOLTAGES MEASURED FROM COMMON NEGATIVE USING V.T.V.M. LINE VOLTAGE SET AT 117 V.A.C. READINGS SHOULD BE AS SHOWN $\pm 20\%$

Bottom view of chassis

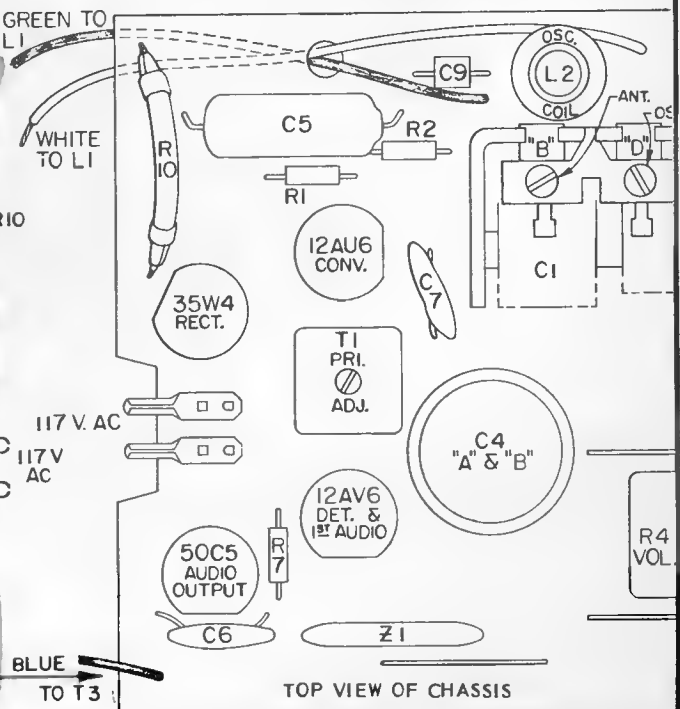
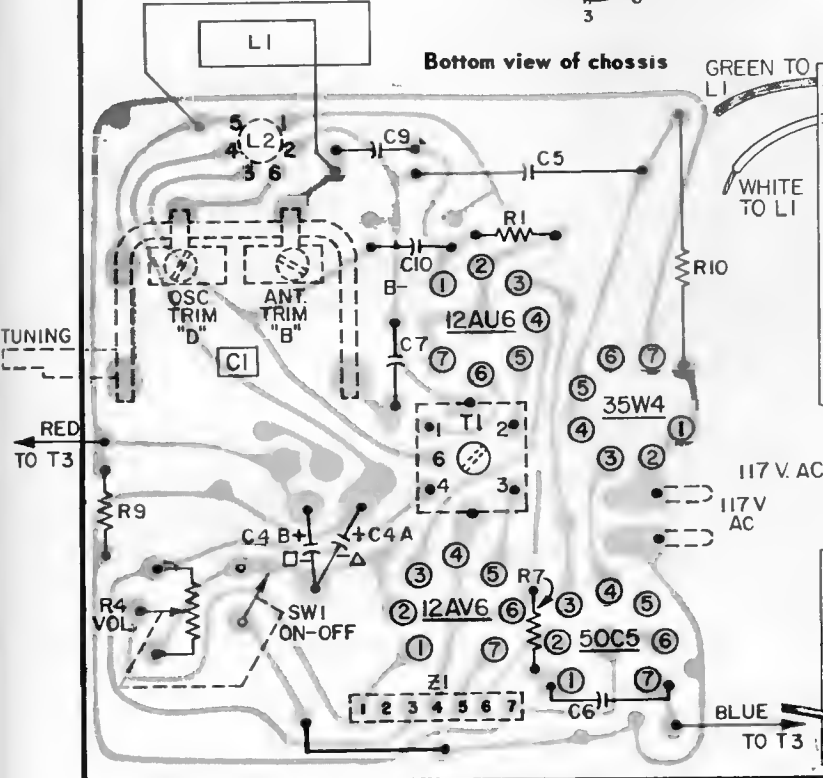

TOP VIEW OF CHASSIS

OFTEN-NEEDED 1959 RADIO SERVICING

WESTINGHOUSE Chassis V-2239-6,
Models H-677T4, H-678T4, H-679T4

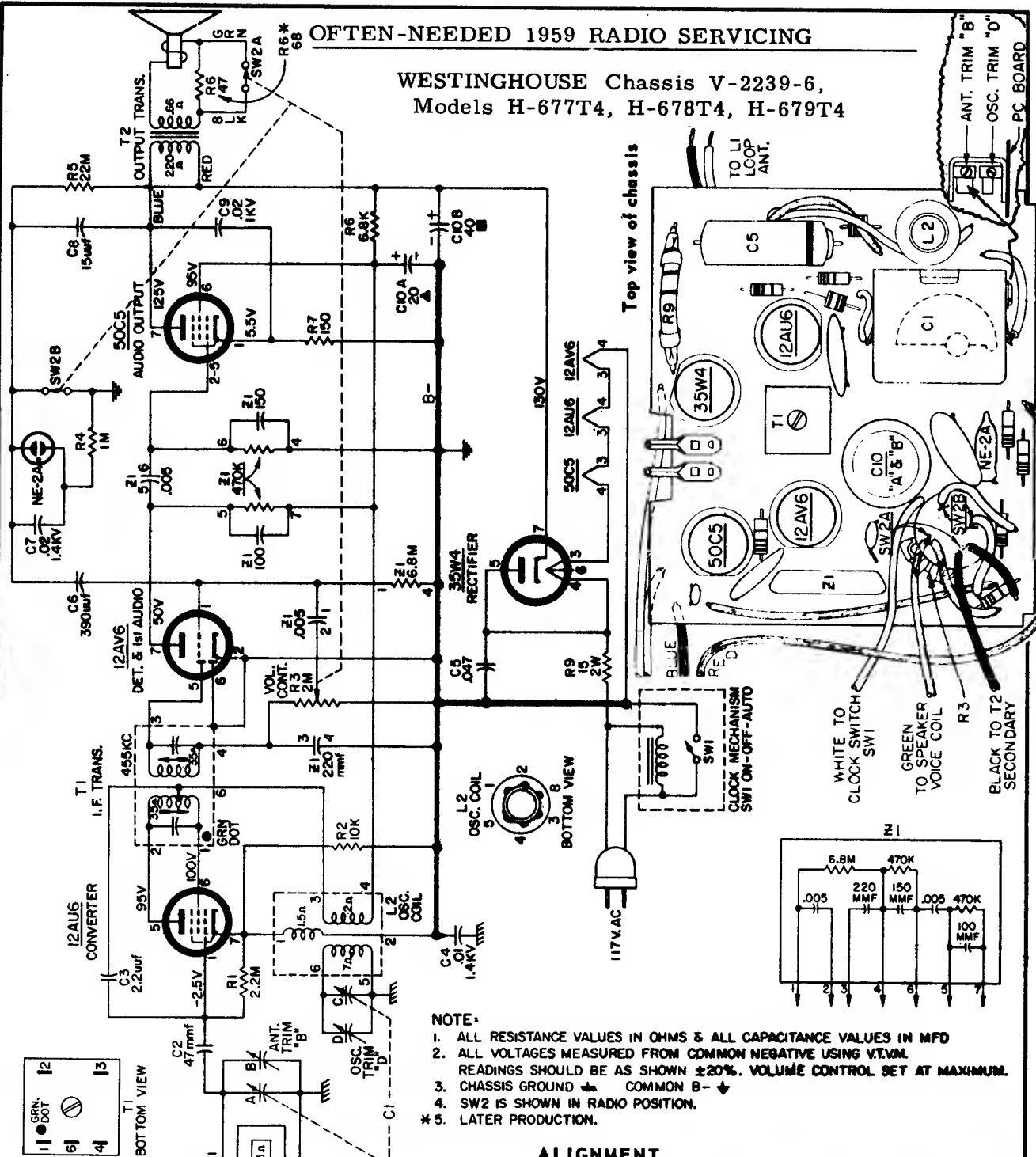

- NOTE:**
1. ALL RESISTANCE VALUES IN OHMS & ALL CAPACITANCE VALUES IN MFD
 2. ALL VOLTAGES MEASURED FROM COMMON NEGATIVE USING VTVM. READINGS SHOULD BE AS SHOWN $\pm 20\%$. VOLUME CONTROL SET AT MAXIMUM.
 3. CHASSIS GROUND \blacktriangle COMMON B- \blacktriangledown
 4. SW2 IS SHOWN IN RADIO POSITION.
 - * 5. LATER PRODUCTION.

ALIGNMENT

While making the following adjustments, keep the volume control set for maximum output and the signal generator output attenuated to weakest usable signal level.

Step	Connect Signal Generator to -	Signal Gen. Frequency	Radio Dial	Connect VTVM Across Voice Coil and Adjust for Maximum Output -
1	Stator of ant. tuning capacitor (A) through a 2DD mfd capacitor.	455 KC 400 Cps. 30% Mod.	Minimum capacity	Top and bottom slugs of T1. *
2	Radiated signal	1625 KC	Minimum capacity	Oscillator trimmer (D)
3	Radiated signal	1400 KC	1400 KC	Antenna trimmer (B)

* It is recommended that a fiber aligning tool that snugly fits the slot in the powdered iron core be used to prevent chipping of the slot.

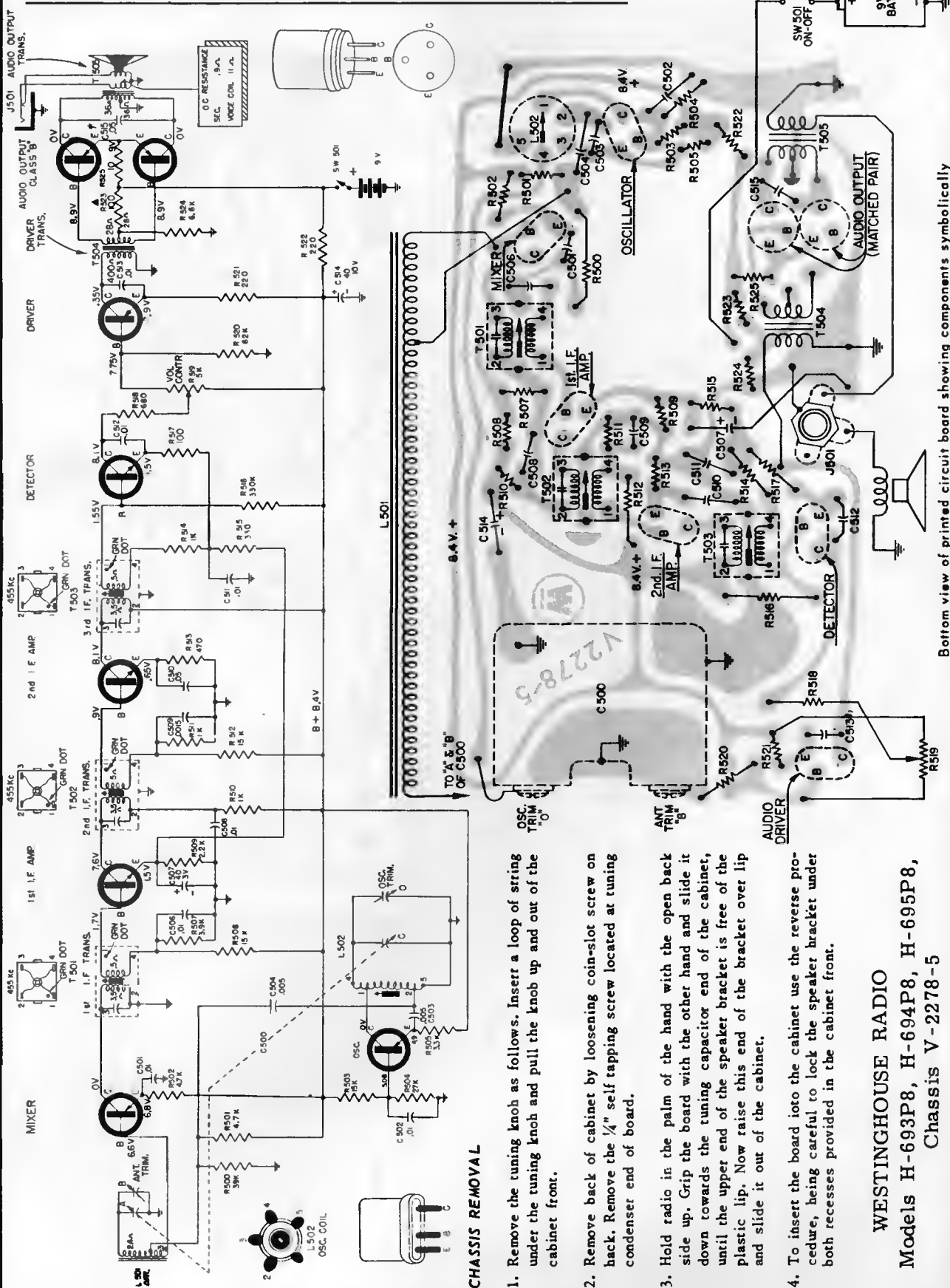

CHASSIS REMOVAL

1. Remove the tuning knob as follows. Insert a loop of string under the tuning knob and pull the knob up and out of the cabinet front.
2. Remove back of cabinet by loosening coin-slot screw on back. Remove the 1/4" self tapping screw located at tuning condenser end of board.
3. Hold radio in the palm of the hand with the open back side up. Grip the board with the other hand and slide it down towards the tuning capacitor end of the cabinet, until the upper end of the speaker bracket is free of the plastic lip. Now raise this end of the bracket over lip and slide it out of the cabinet.
4. To insert the board into the cabinet use the reverse procedure, being careful to lock the speaker bracket under both recesses provided in the cabinet front.

WESTINGHOUSE RADIO

Models H-693P8, H-694P8, H-695P8,
Chassis V-2278-5

Bottom view of printed circuit board showing components symbolically

Westinghouse

Models H-649T7A, H-650T7A,
Chassis V-2392-4

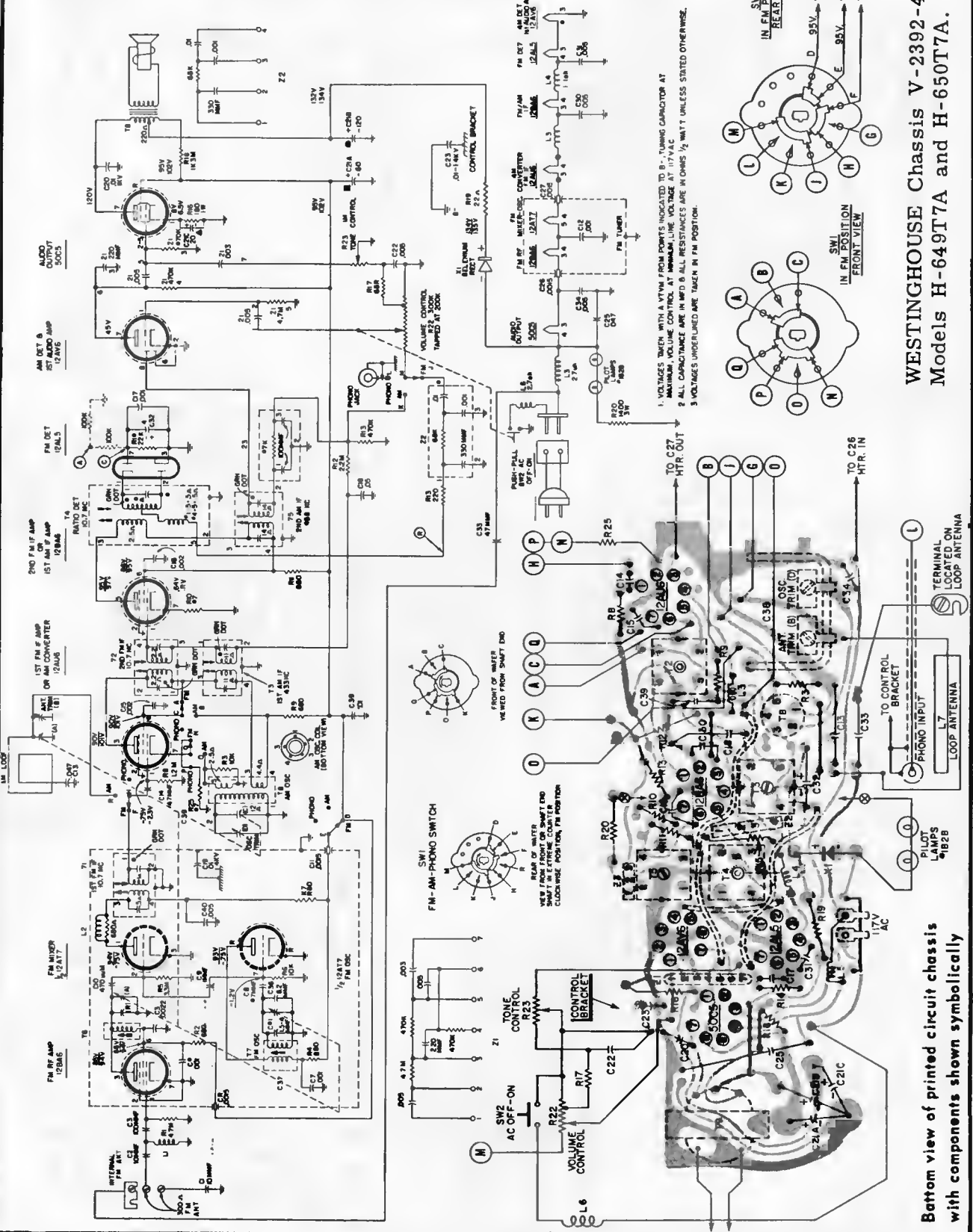

WESTINGHOUSE Chassis V-2392-4,
Models H-649T7A and H-650T7A.

Bottom view of printed circuit chassis
with components shown symbolically

Westinghouse Chassis V-2393-1

Models H-655P5, H-656P5, H-657P5

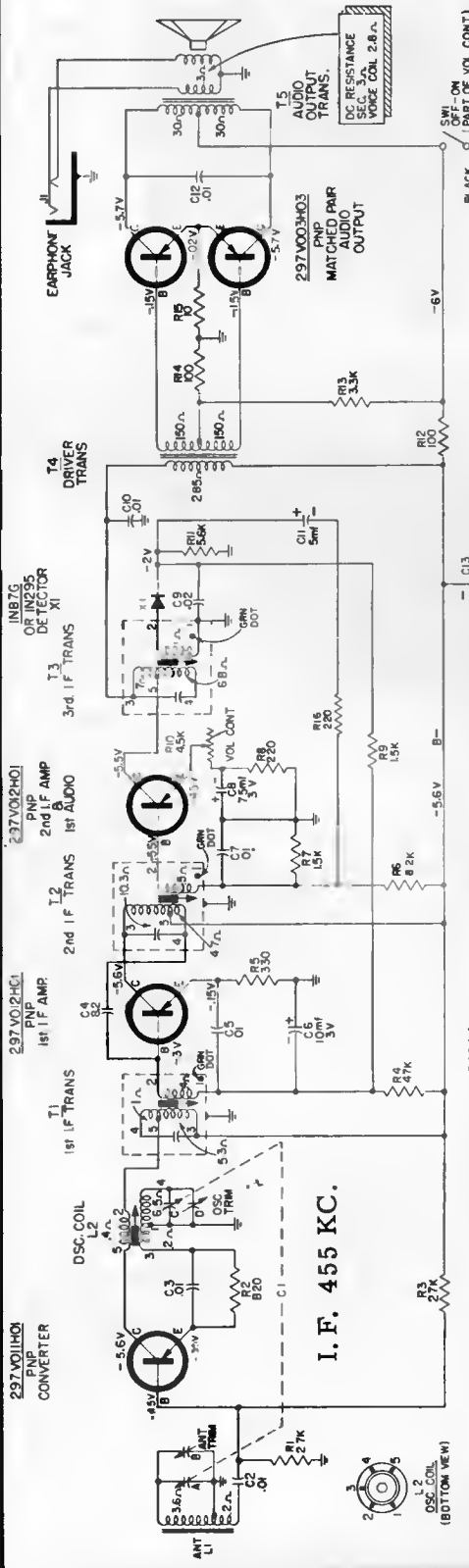

CHASSIS REMOVAL

1. Remove the tuning knob as follows. Insert a loop of string under the tuning knob and pull the knob up and out of the cabinet front.
2. Remove the carrying handle. Grasp the handle on both sides and carefully spread it apart until it clears the holes in the cabinet sides.
3. Remove the back of the cabinet by loosening the two coin-slot screws on the back.
4. Remove the two 1" long hex head screws securing the chassis to the cabinet front.
5. Remove the printed circuit chassis, battery case, speaker spacers, rubber grommet and speaker.
6. To insert the printed circuit chassis back into the cabinet use the reverse procedure. *The tuning knob and cabinet back screws must be the same or identical to the original dimensions to prevent possible damage to the tuning gang.*

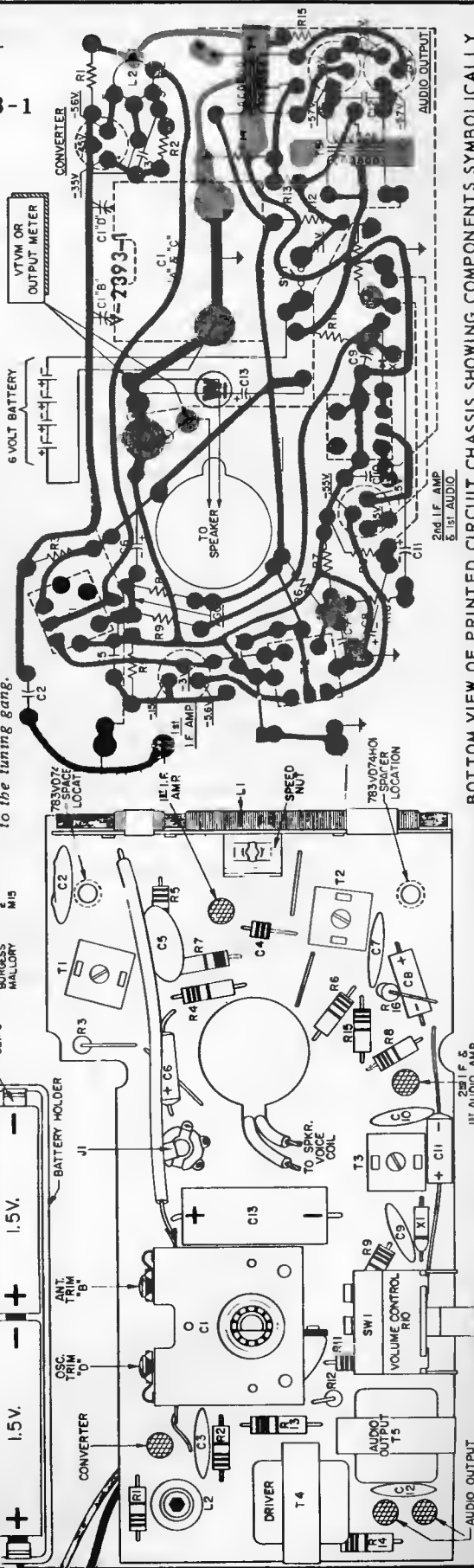

BOTTOM VIEW OF PRINTED CIRCUIT CHASSIS SHOWING COMPONENTS SYMBOLICALLY

TOP VIEW OF PRINTED CIRCUIT CHASSIS

Westinghouse

Chassis V-2394-1, Models H-659P4, H-660P4

CHASSIS REMOVAL (See figure 1)

1. Press in the two cabinet release buttons on either side of the receiver case. Open the case to expose the chassis and batteries.
2. Unsnap the battery cable assemblies from the "A" and "B" batteries.
3. Remove the two self-tapping screws securing the AC receptacle.
4. Remove the two self-tapping screws securing the chassis bracket to the top of the case.
5. Carefully slide the chassis out from the receiver case. The on-off-volume control knob is captivated and thus remains in the case as the control shaft is pulled off the knob.

When servicing with the receiver connected to the AC power line use an isolation transformer between the receiver and the AC line. To replace the chassis reverse the above procedure. Be careful to correctly seat the chassis in the cabinet mounting grooves.

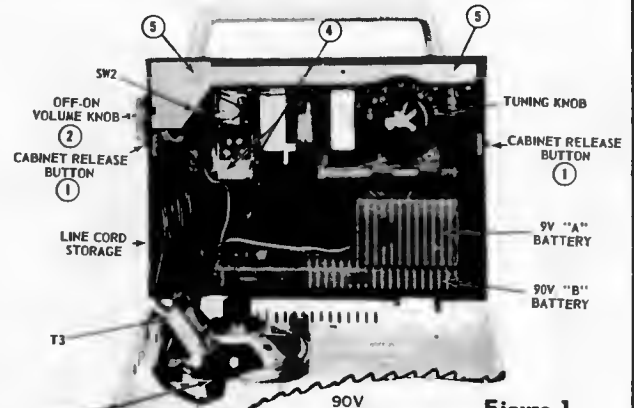
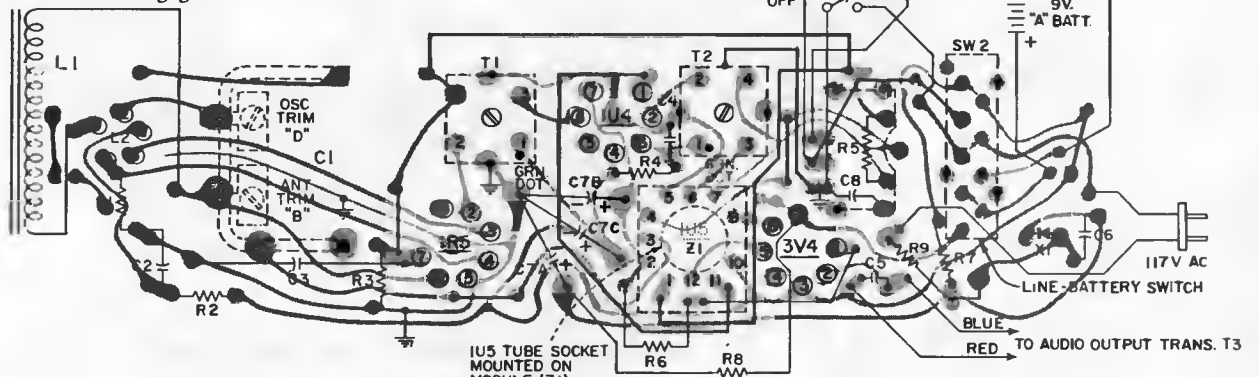
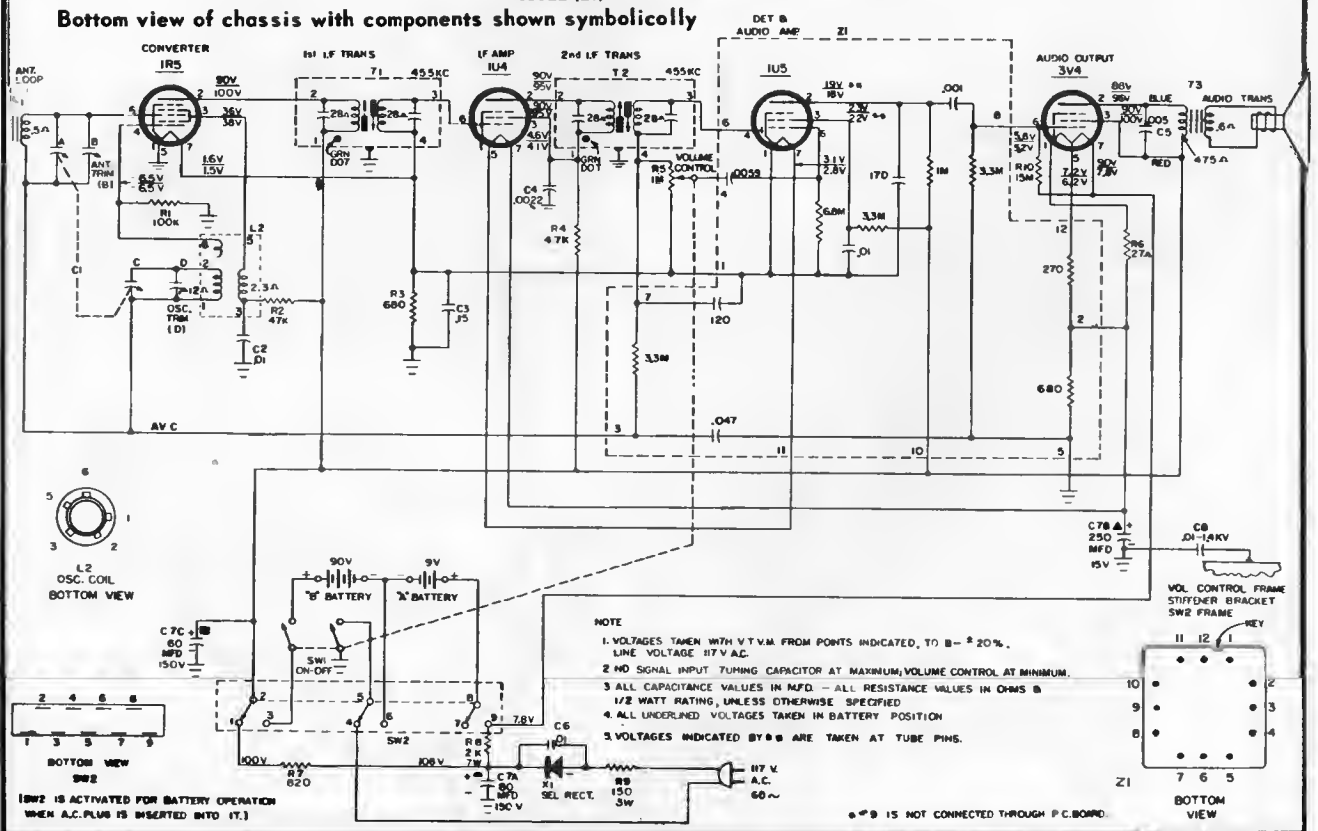
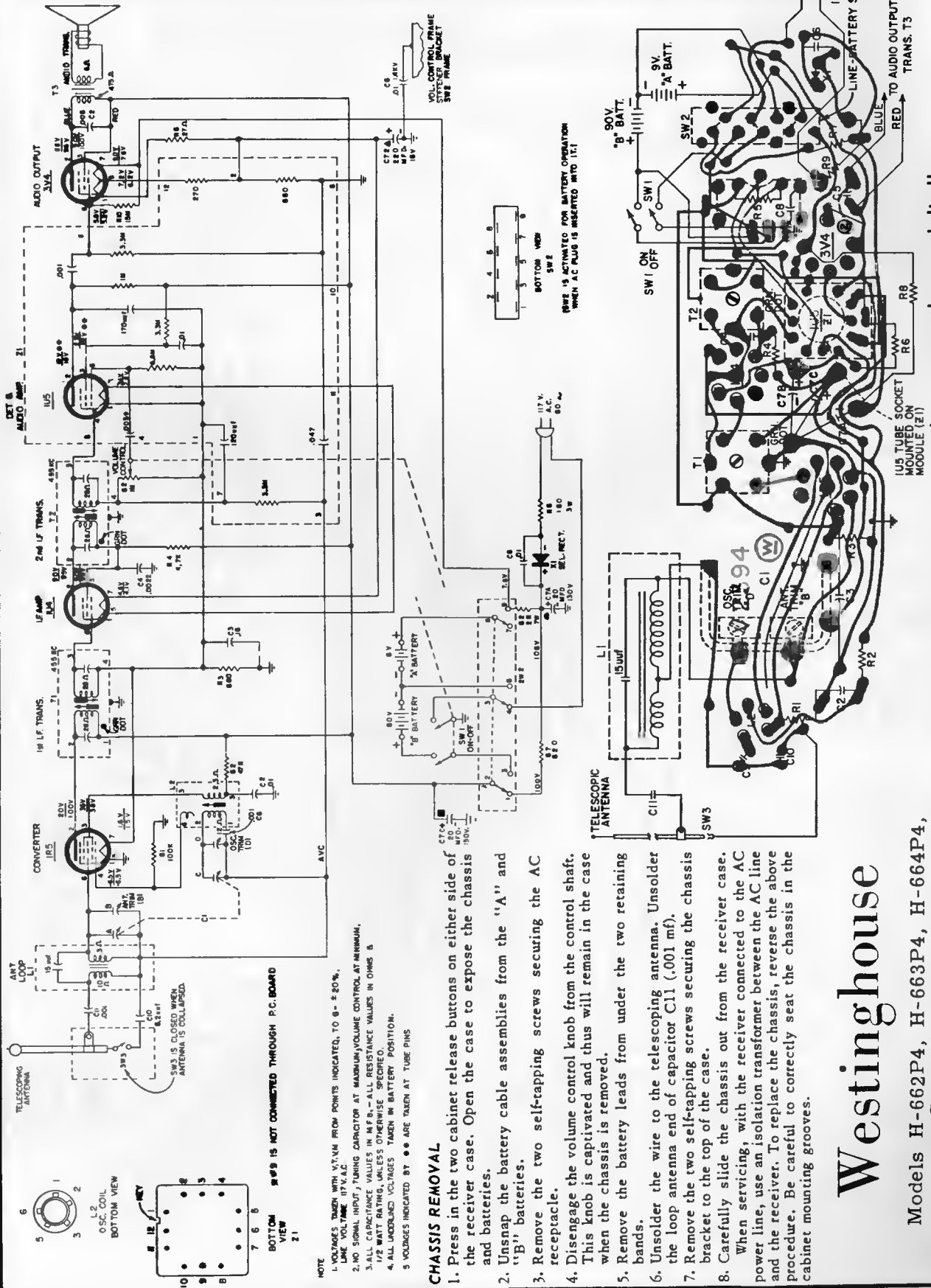

Figure 1



Bottom view of chassis with components shown symbolically





Bottom view of chassis with components shown symbolically

CHASSIS REMOVAL

1. Press in the two cabinet release buttons on either side of the receiver case. Open the case to expose the chassis and batteries.
2. Unsnap the battery cable assemblies from the "A" and "B" batteries.
3. Remove the two self-tapping screws securing the AC receptacle.
4. Disengage the volume control knob from the control shaft. This knob is caprivated and thus will remain in the case when the chassis is removed.
5. Remove the battery leads from under the two retaining bands.
6. Unsolder the wire to the telescoping antenna. Unsolder the loop antenna end of capacitor C11 (.001 mf).
7. Remove the two self-tapping screws securing the chassis bracket to the top of the case.
8. Carefully slide the chassis out from the receiver case.

When servicing, with the receiver connected to the AC power line, use an isolation transformer between the AC line and the receiver. To replace the chassis, reverse the above procedure. Be careful to correctly seat the chassis in the cabinet mounting grooves.

Westinghouse

Models H-662P4, H-663P4, H-664P4,
Chassis V-2394-2

- NOTE**
1. VOLTAGES TAKEN WITH V.T.V.M FROM POINTS INDICATED, TO 0 - ±20%.
 2. NO SIGNAL INPUT, TUNING CAPACITOR AT MAXIMUM/VOLUME CONTROL AT MINIMUM.
 3. ALL CAPACITANCE VALUES IN M.F.R. - ALL RESISTANCE VALUES IN OHMS Ω.
 4. ALL UNDERLINED VOLTAGES TAKEN IN BATTERY POSITION.
 5. VOLTAGES INDICATED BY ●● ARE TAKEN AT TUBE PINS

SW3 IS NOT CONNECTED THROUGH P.C. BOARD

SW2 IS ACTIVATED FOR BATTERY OPERATION WHEN AC PLUG IS INSERTED INTO T11



Westinghouse®

Models H-681T5, H-682T5, H-683T5,
Chassis V-2395-1

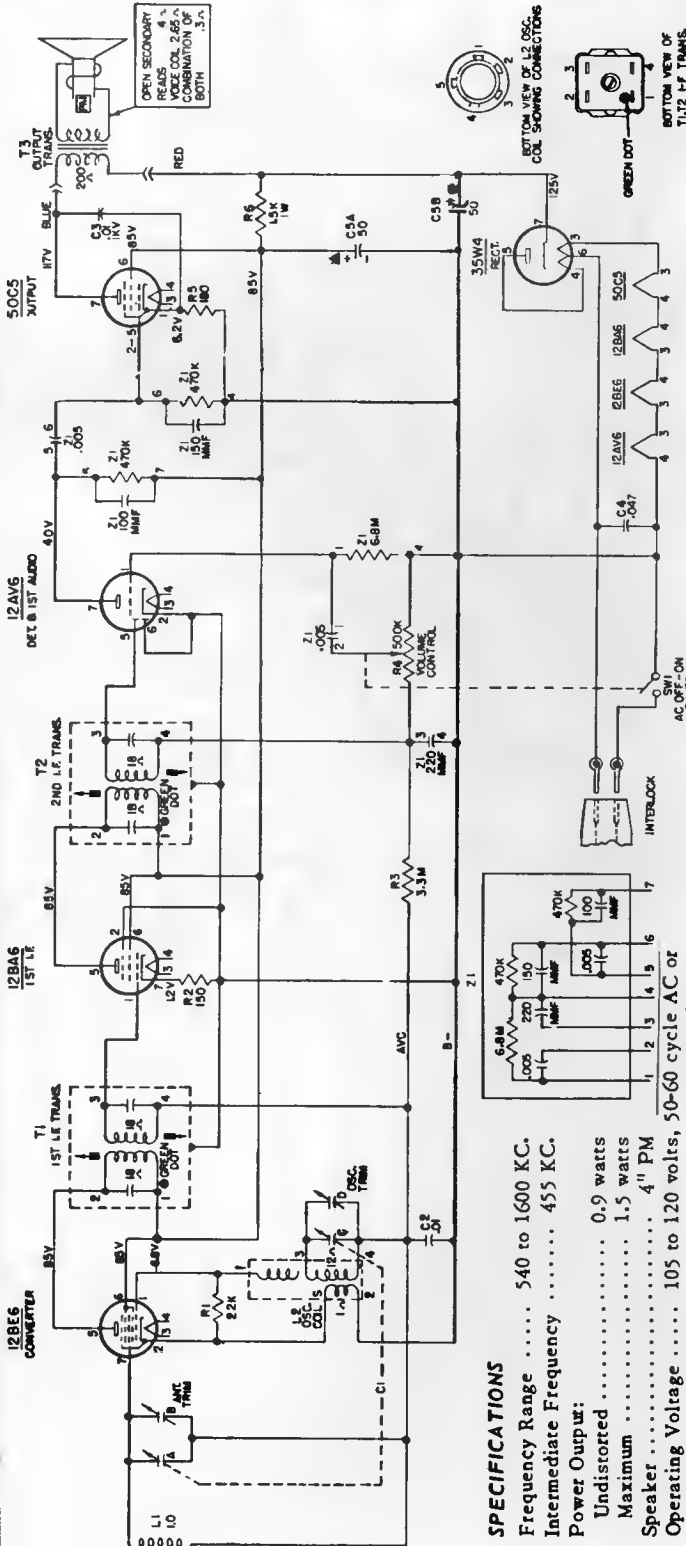

SPECIFICATIONS

- Frequency Range 540 to 1600 KC.
- Intermediate Frequency 455 KC.
- Power Output:
Undistorted 0.9 watts
Maximum 1.5 watts
- Speaker 4" PM
- Operating Voltage 105 to 120 volts, 50-60 cycle AC or 105 to 120 volts DC
- Power Consumption 30 watts

PRINTED BOARD REMOVAL

1. Disengage captivated volume control knob (located on side of cabinet) from volume control shaft.
2. Remove two screws from rear of cabinet.
3. Loosen screw on bottom of cabinet slightly; then push forward on this screw to disengage AC line cord interlock.
4. Remove screw from bottom of cabinet. Front panel and attached PC board can now be removed from cabinet.
5. For PC board installation reverse the above procedure.

FRONT PANEL REMOVAL

1. Remove front panel and attached PC board as described under PRINTED BOARD REMOVAL.
2. Unsolder red and blue leads from audio output transformer (transformer is mounted on speaker).
3. Remove the screw securing loop antenna assembly to front panel.
4. Remove two screws attaching PC board stiffener bracket to front panel.
5. For front panel installation * reverse the above procedure.
* NOTE: The tuning knob must be replaced before PC board assembly is attached to front panel.

NOTES:

1. ALL VOLTAGE READINGS FROM COMMON HEATING LEADS USING 5-WATT VA VOLUME CONTROL AT MINIMUM, TUNING CAPACITOR AT MAXIMUM.
2. ALL CAPACITANCE VALUES IN MICRO, AND ALL RESISTANCE VALUES IN OHMS UNLESS OTHERWISE SPECIFIED.

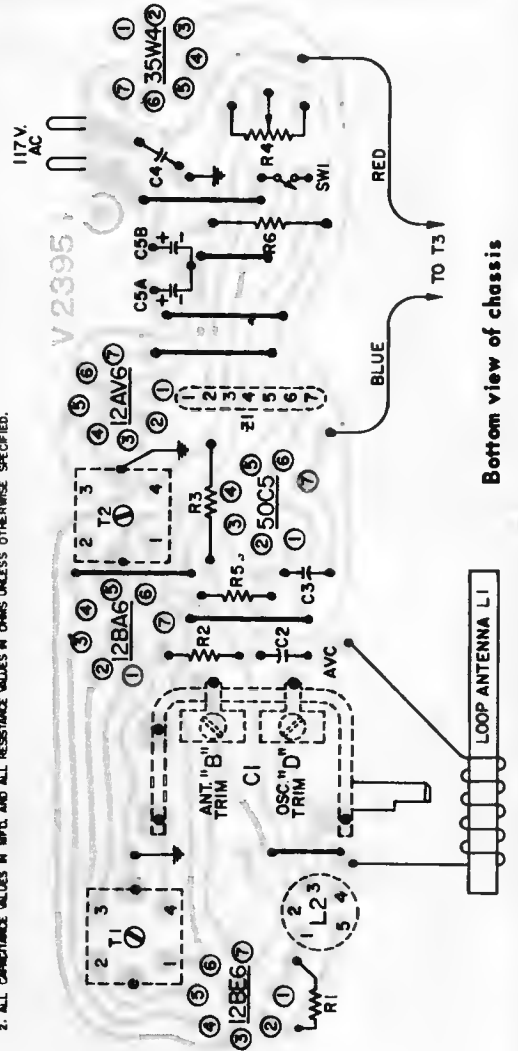

WESTINGHOUSE Chassis V-2396-1
Models H-685P8, H-686P8

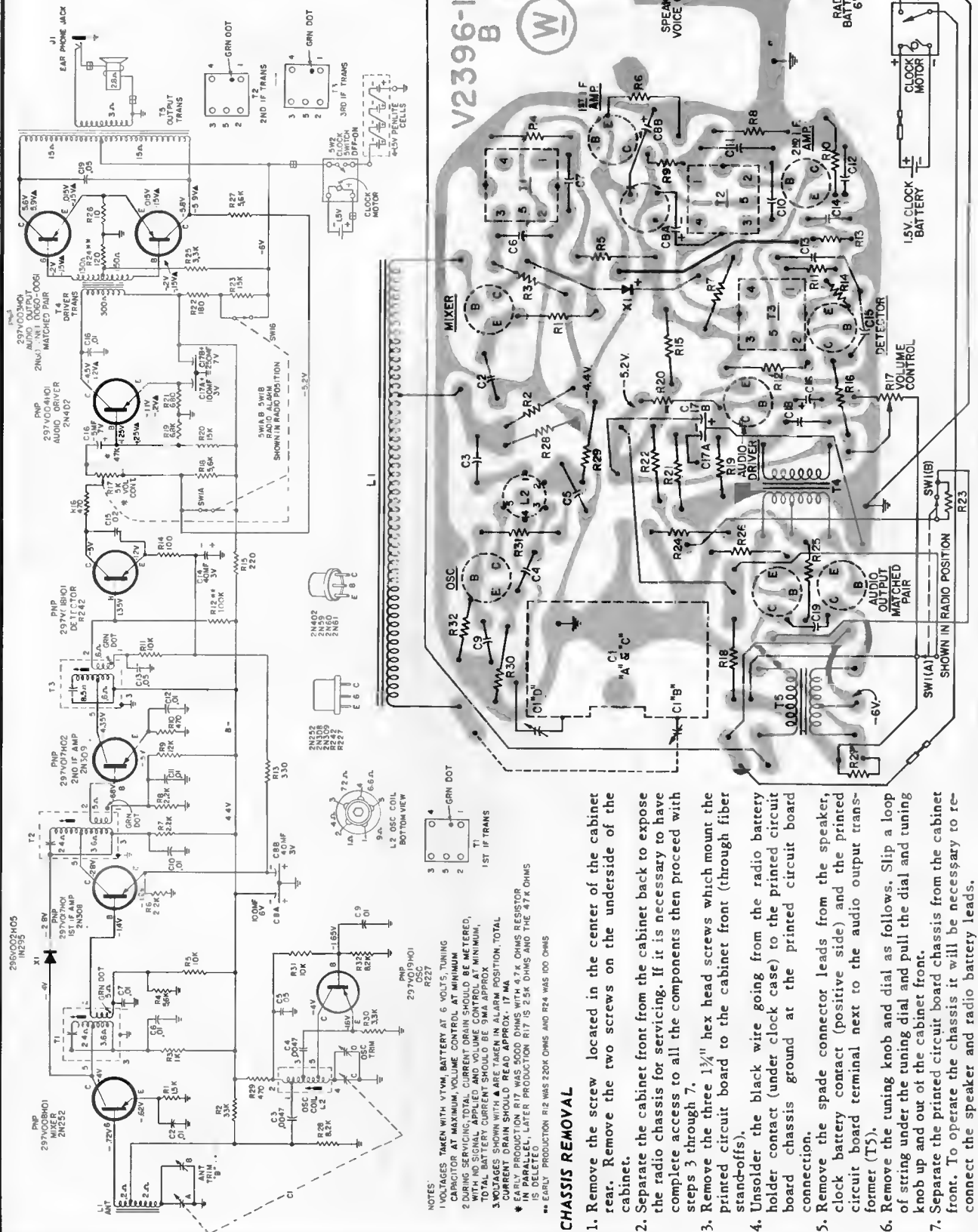

Bottom view of printed circuit board with components shown symbolically.

VOLUME R-19, MOST-OFTEN-NEEDED 1959 RADIO SERVICING INFORMATION

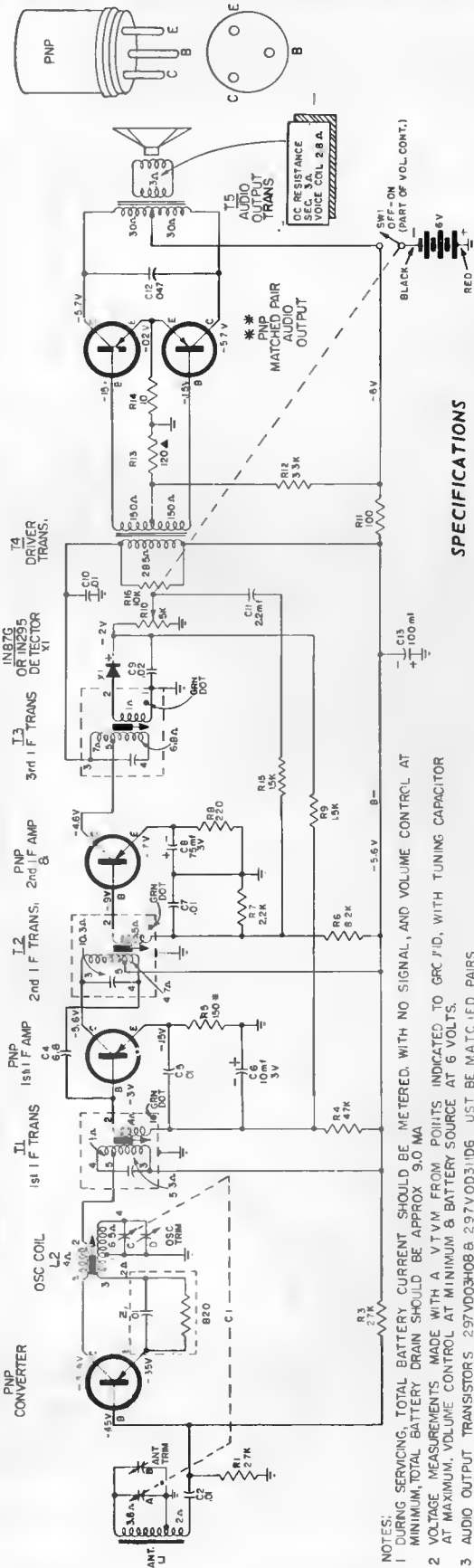

SPECIFICATIONS

- Frequency Range.....540 to 1600 KC
- Intermediate Frequency.....455 KC
- Power Supply—6 volts (four 1.5 volt "C" batteries)
- No Signal Current Drain......9 ma

CHASSIS REMOVAL

1. Remove the volume control knob.
2. Remove the tuning control knob. Insert a loop of string under the tuning knob and pull the knob out of the cabinet front.
3. Remove the phillips head screw in the tuning control knob well.
4. Remove the back cover (loosen the two coin-slot screws).
5. Remove the two hex head screws securing the chassis to the cabinet.
6. Remove the chassis, with its battery holder, from the cabinet. The receiver can now be serviced. If it is necessary to also remove the speaker, then remove the two hex head screws securing the speaker and lift it out of its slot.
7. Use the reverse of the above steps to replace the chassis into the cabinet. If replaced, the mounting screw that is used in the tuning control knob well must be the same length as the original, so as to not damage the tuning capacitor.

Westinghouse

Model H-690P5, Chassis V-2397-1

- NOTES:
- 1 DURING SERVICING, TOTAL BATTERY CURRENT SHOULD BE METERED WITH NO SIGNAL, AND VOLUME CONTROL AT MINIMUM. TOTAL BATTERY DRAIN SHOULD BE APPROX 9.0 MA
 - 2 VOLTAGE MEASUREMENTS MADE WITH A VTVM FROM POINTS INDICATED TO GRC P/D, WITH TUNING CAPACITOR AT MAXIMUM. VOLUME CONTROL AT MINIMUM & BATTERY SOURCE AT 6 VOLTS.
 - 3 AUDIO OUTPUT TRANSISTORS 297V003H08 297V003I106 MUST BE MATC. LOTS
 - 4 ALL CAPACITORS LESS THAN ONE μF ARE IN μFD. ALL CAPACITORS GREATER THAN ONE μF ARE IN MMFD. UNLESS OTHERWISE SPECIFIED, ALL RESISTORS ARE IN OHMS. 1/2 WATT.

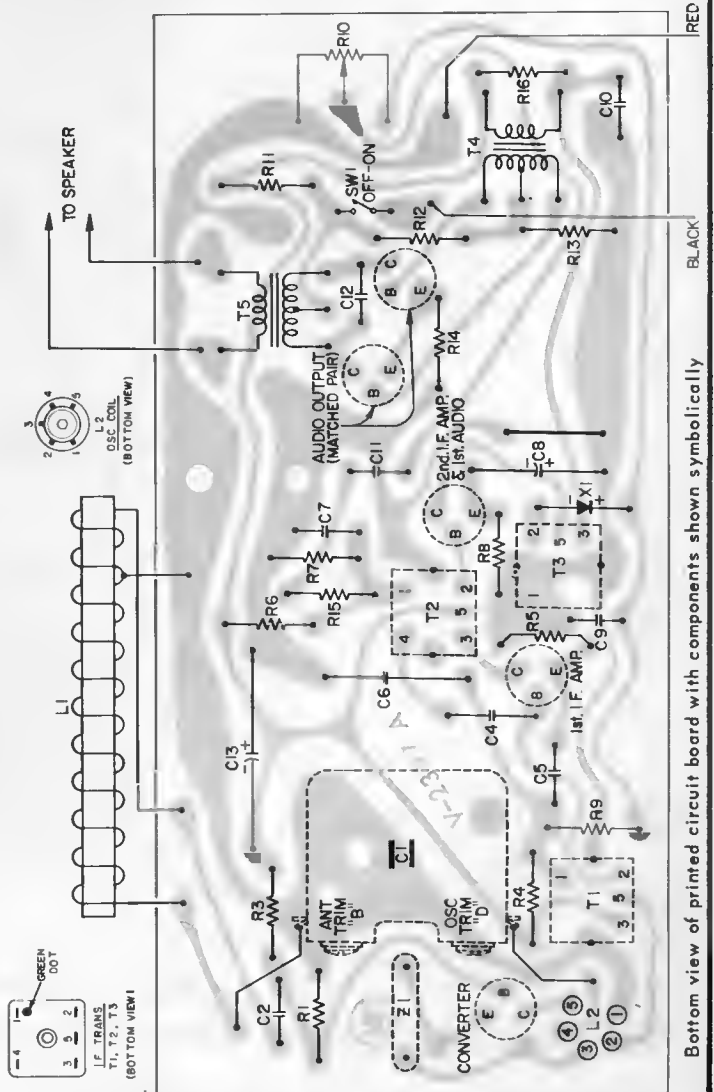

Bottom view of printed circuit board with components shown symbolically

Westinghouse

Models HF-110AN, HF-111AN,
Chassis V-2503-2

- 1 ALL CAPACITANCE VALUES IN MFO AND ALL RESISTANCE VALUES IN OHMS UNLESS OTHERWISE SPECIFIED.
- 2 ALL VOLTAGES MEASURED TO B-USING A VTVM., LINE VOLTAGE SET AT 117V AC, VOLTAGES SHOULD BE AS SHOWN $\pm 20\%$. NO SIGNAL INPUT, LOUDNESS AT MINIMUM.

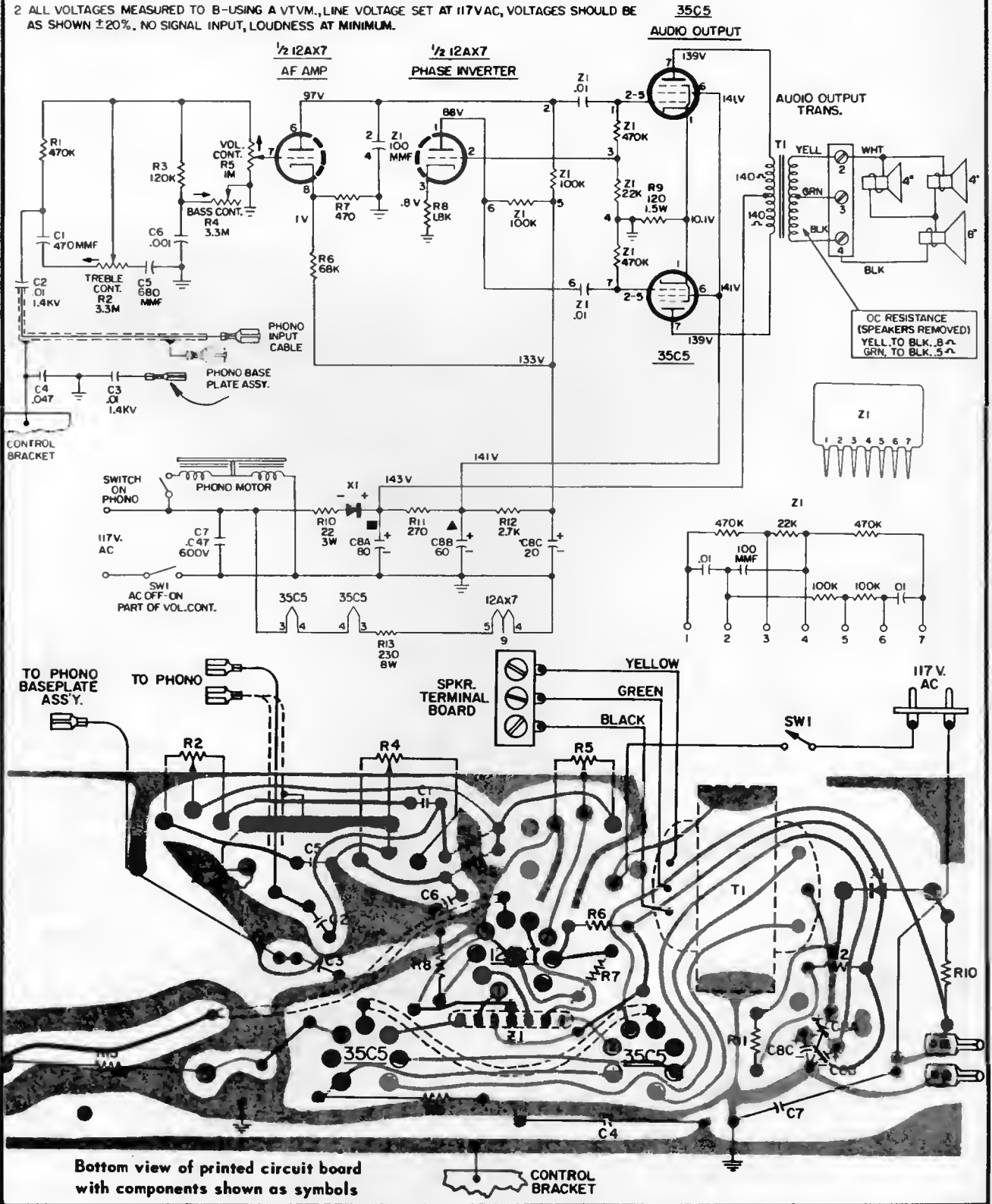

Westinghouse

CHASSIS V-2503-3

MODELS

H46AC1

H46AC2

H46AC3

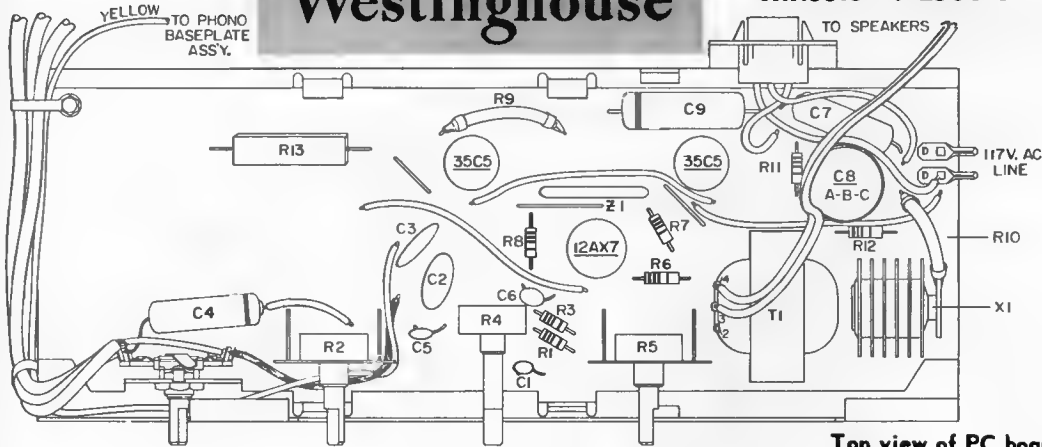

Top view of PC board.

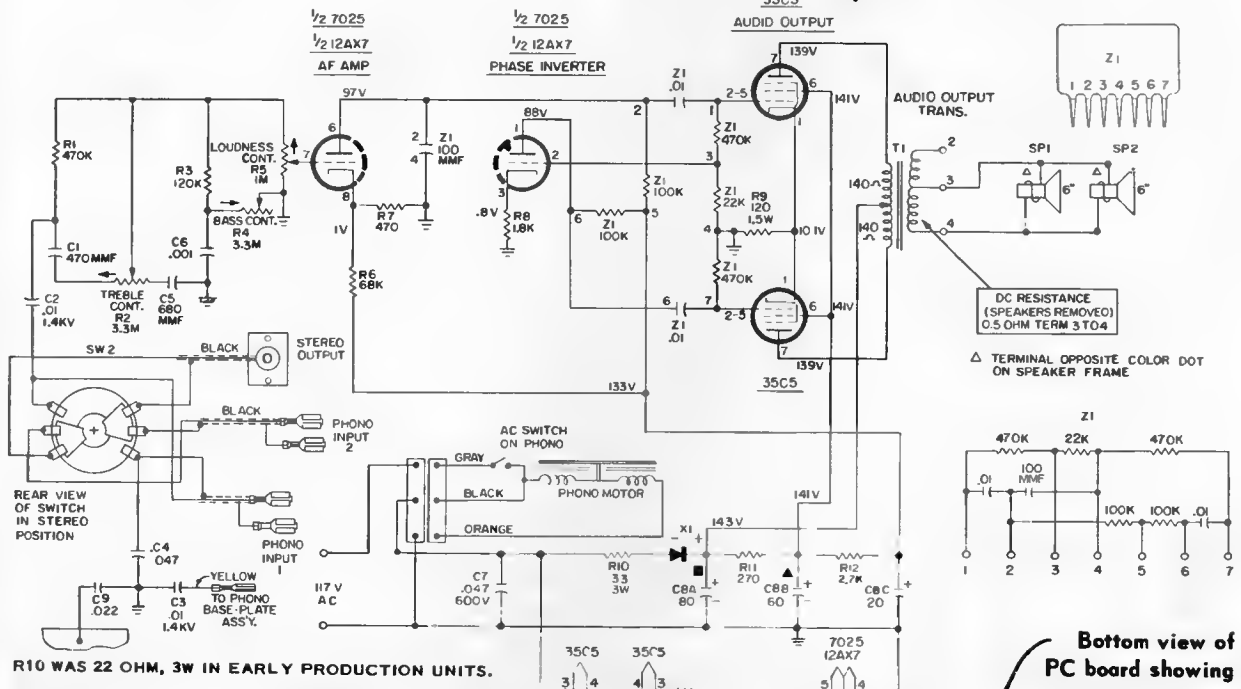

Bottom view of PC board showing top components as schematic symbols.

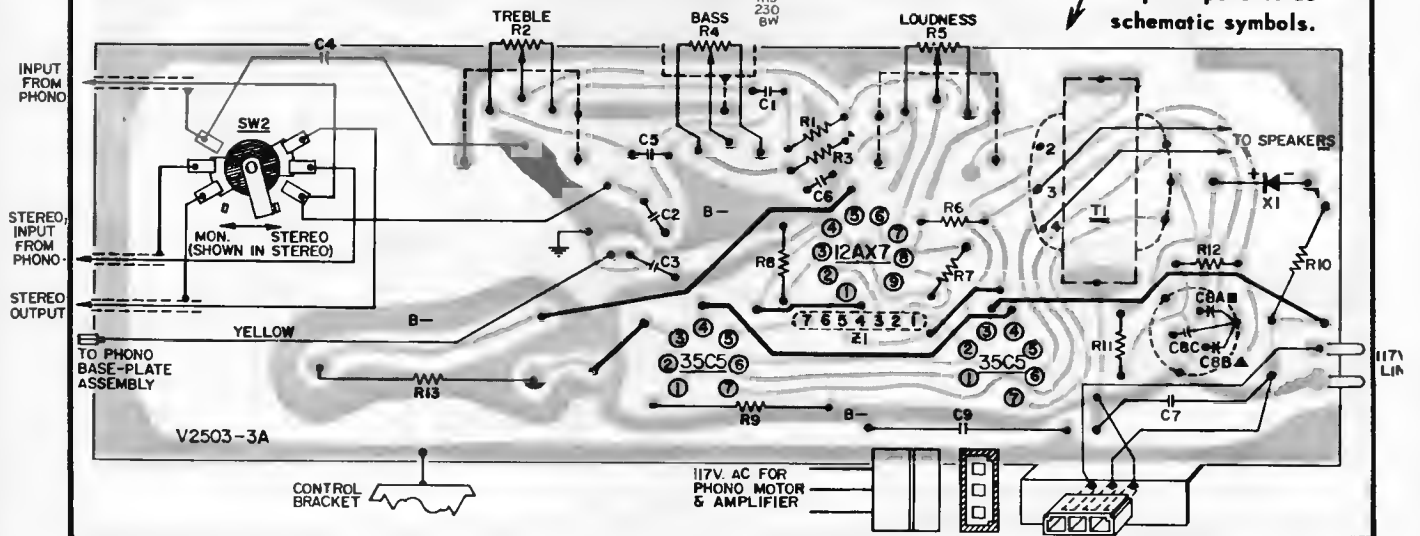



Models H-45AC1A, H-45AC2A,
Chassis V-2506-3

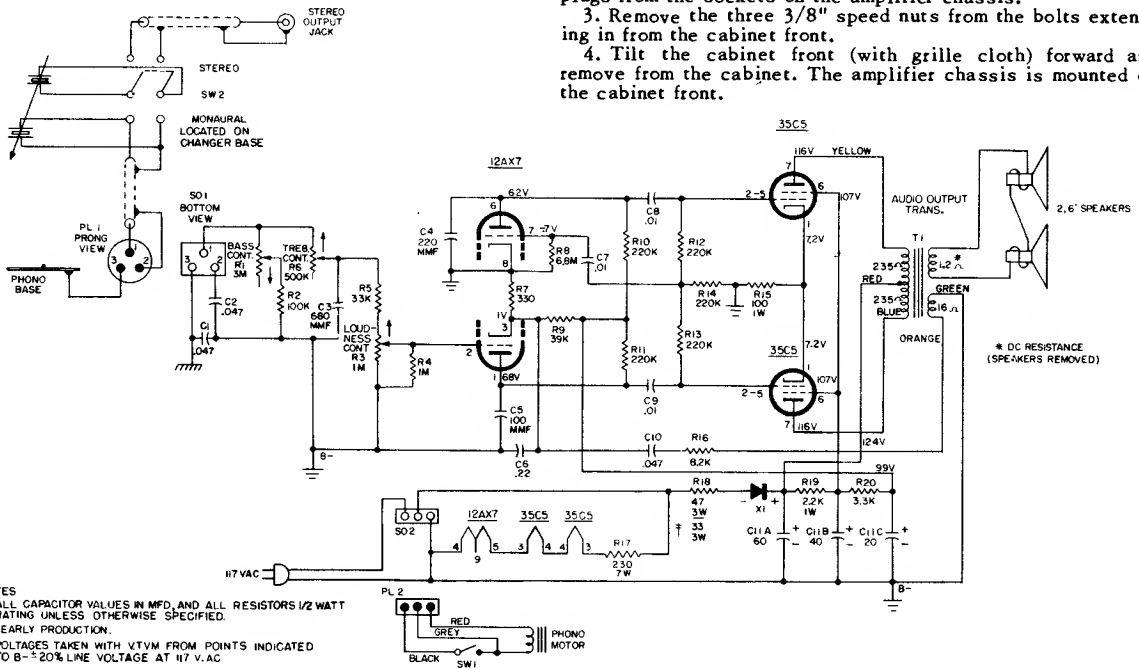

TUBE REPLACEMENT

To replace the vacuum tubes it is first necessary to remove the cover at the rear of the speaker baffle. This cover has ventilating holes and is secured by two phillips-head screws.

CHASSIS REMOVAL

1. Remove the cover at the rear of the speaker baffle. This cover has ventilating holes and is secured by two phillips-head screws.
2. Remove the record changer mounting board. This is secured by four phillips-head screws, one in each corner of the board. Lift the board up and out of the cabinet. To completely detach the changer from the phonograph remove the two cable plugs from the sockets on the amplifier chassis.
3. Remove the three 3/8" speed nuts from the bolts extending in from the cabinet front.
4. Tilt the cabinet front (with grille cloth) forward and remove from the cabinet. The amplifier chassis is mounted on the cabinet front.

WESTINGHOUSE Models H-44AC1A, H-44AC2A, Chassis V-2506-2.

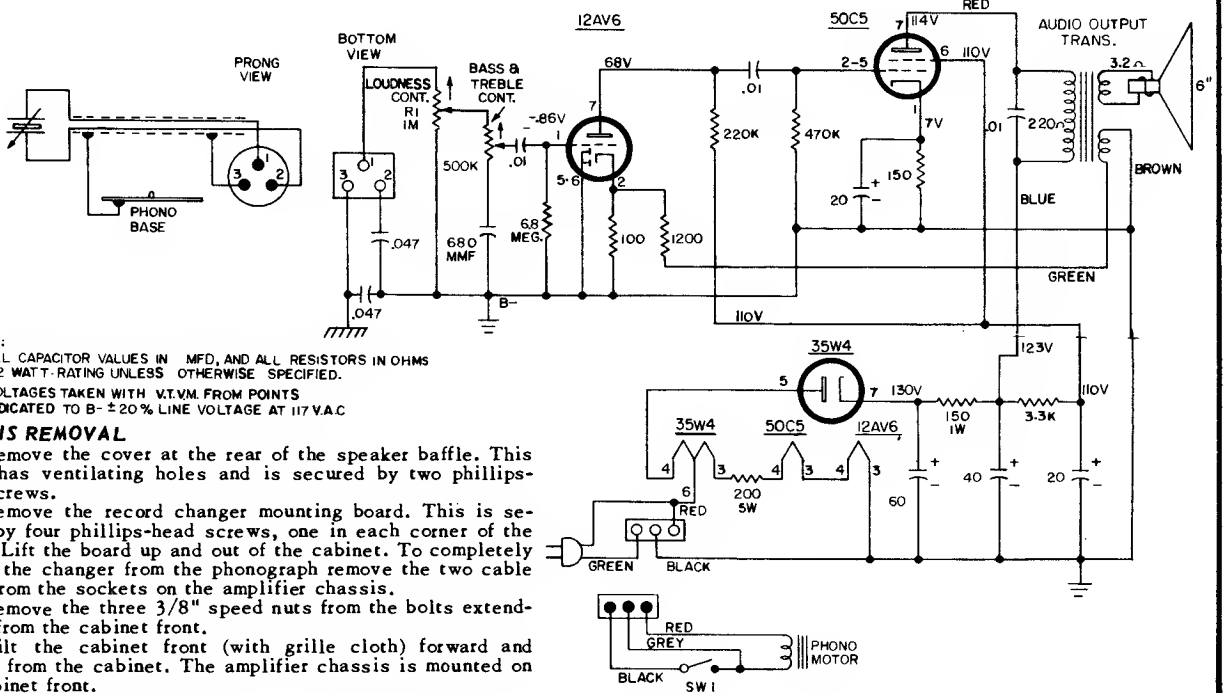

ZENITH RADIO MODELS HF110G & J CHASSIS 3Z04

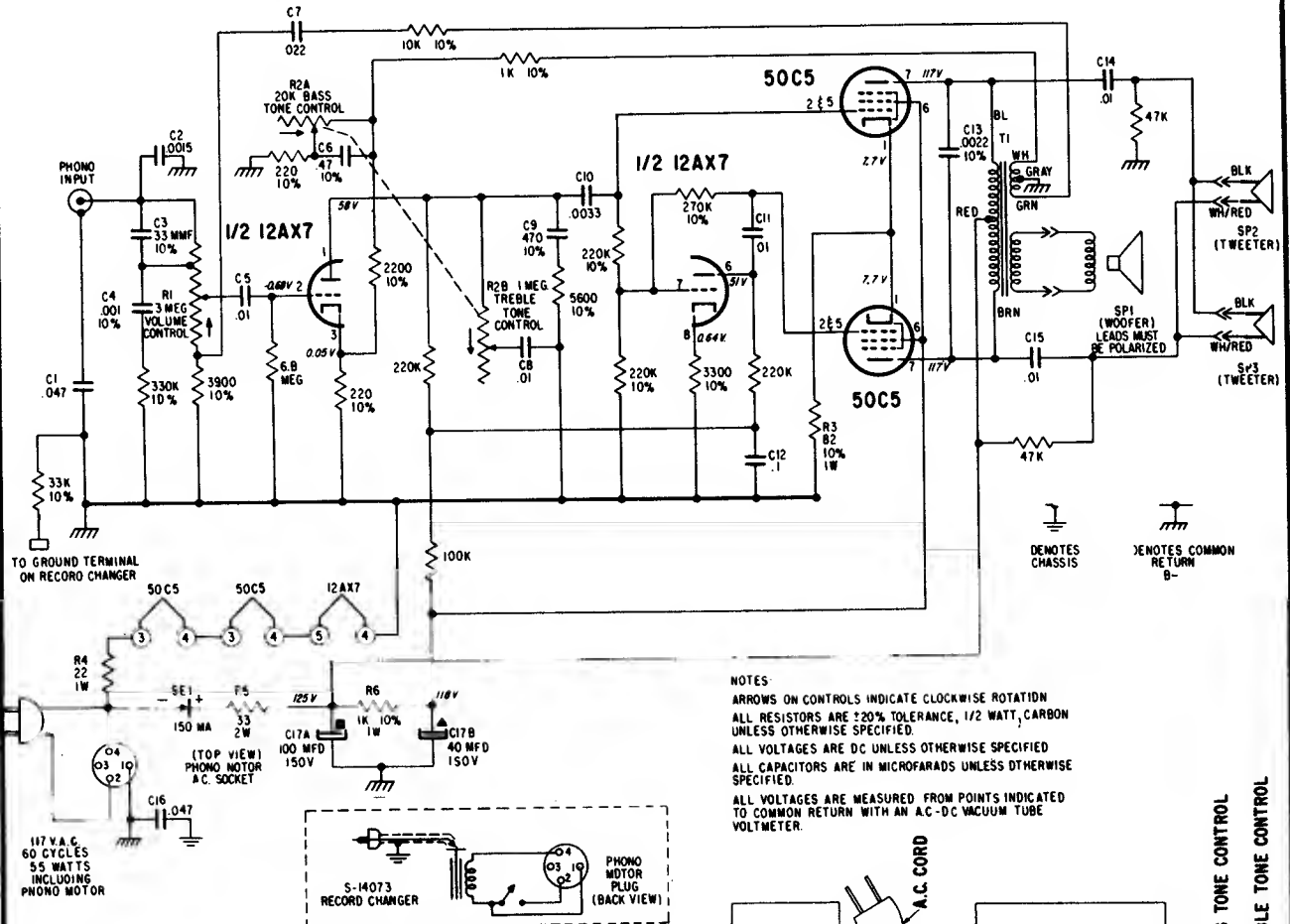

NOTES
 ARROWS ON CONTROLS INDICATE CLOCKWISE ROTATION
 ALL RESISTORS ARE ±20% TOLERANCE, 1/2 WATT, CARBON UNLESS OTHERWISE SPECIFIED.
 ALL VOLTAGES ARE DC UNLESS OTHERWISE SPECIFIED
 ALL CAPACITORS ARE IN MICROFARADS UNLESS OTHERWISE SPECIFIED.
 ALL VOLTAGES ARE MEASURED FROM POINTS INDICATED TO COMMON RETURN WITH AN AC-DC VACUUM TUBE VOLTMETER.

MODELS HF110, G & J CABINET PARTS Using Chassis 3Z04 DESCRIPTION

PART NO.	DIA. ND.	DESCRIPTION
14-2405G		Table Cabinet - Model HF110G
14-2405J		Table Cabinet - Model HF110J
19-298		Mounting Clip (mts. S-41437)
24-923		Chassis Cover - Model HF110J
24-924		Chassis Cover - Model HF110G
36-210		Cabinet Handle (part of 14-2405G)
36-211		Cabinet Handle (part of 14-2405J)
40-157		Lid Support Hinge (part of 14-2405, G & J)
40-189		Hinge (2 part of 14-2405 G & J)
46-1318		Knob - Volume & Tone HF110J
46-2001		Knob - Volume & Tone HF110G
49-795	SP1	7 1/2" P.M. Speaker
83-765		Armite strip (2 used)
83-1475		Armite strip
83-2535		Phono Shipping Strip (2 used)
83-2761		Phono Shipping Strip
86-254		Terminal (4 used)
93-1173		6 Finishing Washer (1 used on ea. 70-239)
93-1260		Fibre Washer (2 part of S-14083)
142-87		Dual Cartridge (Sapphire-Sapphire)
156-45		Cover Latch (2 part of 14-2405J)
159-94		Plug Button (4 used on 14-2405G & J)
159-95		Plug Button Screen (2 used on 14-2405G & J)
166-114		Plastic Bumper (4 part of 14-2405 G & J)
188-102		Knob Retaining Ring (1 part of ea. S-43478, 43479, 44126 & 44127)
188-195		Retaining Ring (2 part of S-14083)
202-1362		Instruction Book
S-14083		Record Changer
S-23829	SP2, 3	Tweeter Speaker (2 used)
S-41437		45 RPM Record Adapter
S-42308		Cartridge Holder (part of S-14083)
S-43478		Knob & Ring Assem.
S-43479		Knob & Ring Assem.
S-44126		Knob Ring Assem. Tone HF110G
S-44127		Knob & Ring Assem. Dummy HF110G

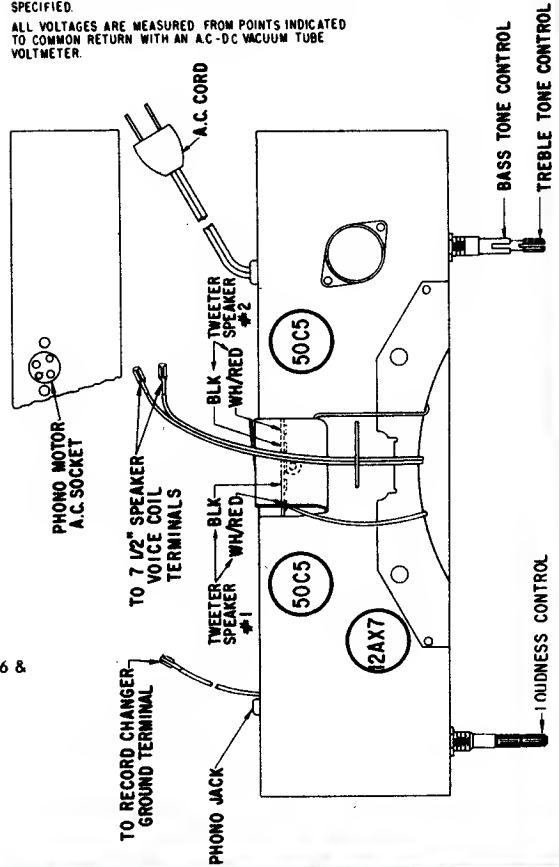

ZENITH RADIO CORP. MODELS SF174R & SF177E & R

CHASSIS 4B22, 4B23, 3B30

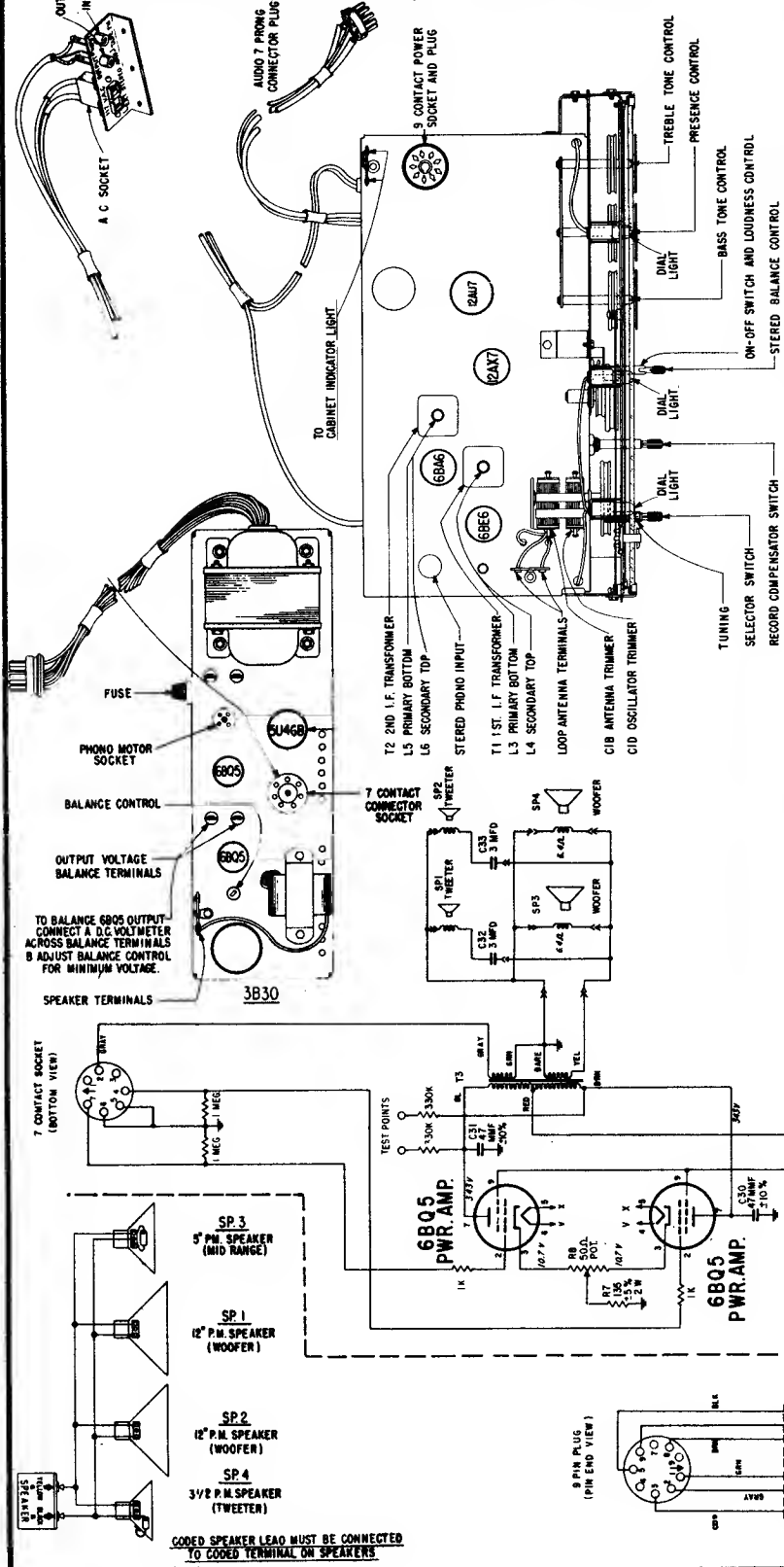

TUBE, TRIMMER LOCATION AND DETAILED VIEW OF I.F. TRANSFORMERS

ALIGNMENT PROCEDURE

Operation	Connect Oscillator to Antenna	Dummy Antenna Frequency	Set Dial at	Trimmers	Purpose
1	Converter Grid	.5 Mfd.	600 Kc.	L3, L4, L5, L6	Align I.F. for maximum output.
2	One turn Loop Coupled Loosely to Wave Magnet	1600 Kc.	1600 Kc.	C1D	Set Osc. to Dial Scale
3			1400 Kc.	C1B	Align Antenna Stage

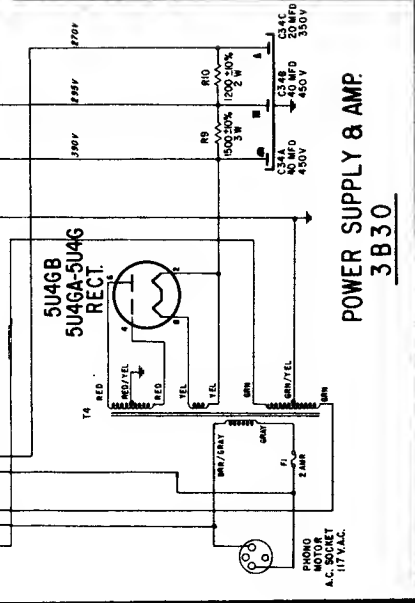

ZENITH RADIO CORPORATION MODEL SF112, CHASSIS 4B24-4B25 & REMOTE SPEAKER SRS2

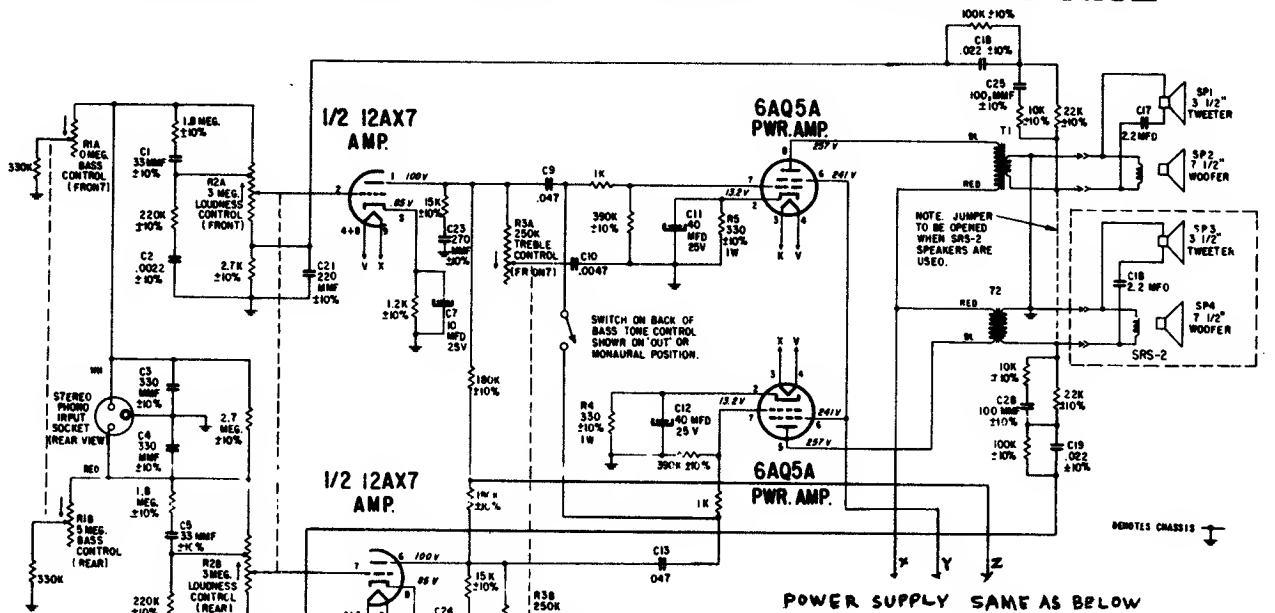

4B24 CHASSIS

POWER SUPPLY SAME AS BELOW

- NOTES:
 ARROW ON CONTROLS INDICATES CLOCKWISE ROTATION.
 ALL RESISTORS ARE 20% TOLERANCE. 1/2 WATT, CARBON UNLESS OTHERWISE SPECIFIED.
 ALL VOLTAGES ARE D.C. UNLESS OTHERWISE SPECIFIED.
 ALL VOLTAGES ARE MEASURED WITH POINTS INDICATED TO CHASSIS WITH AN A.C.-D.C. VACUUM TUBE VOLTMETER.

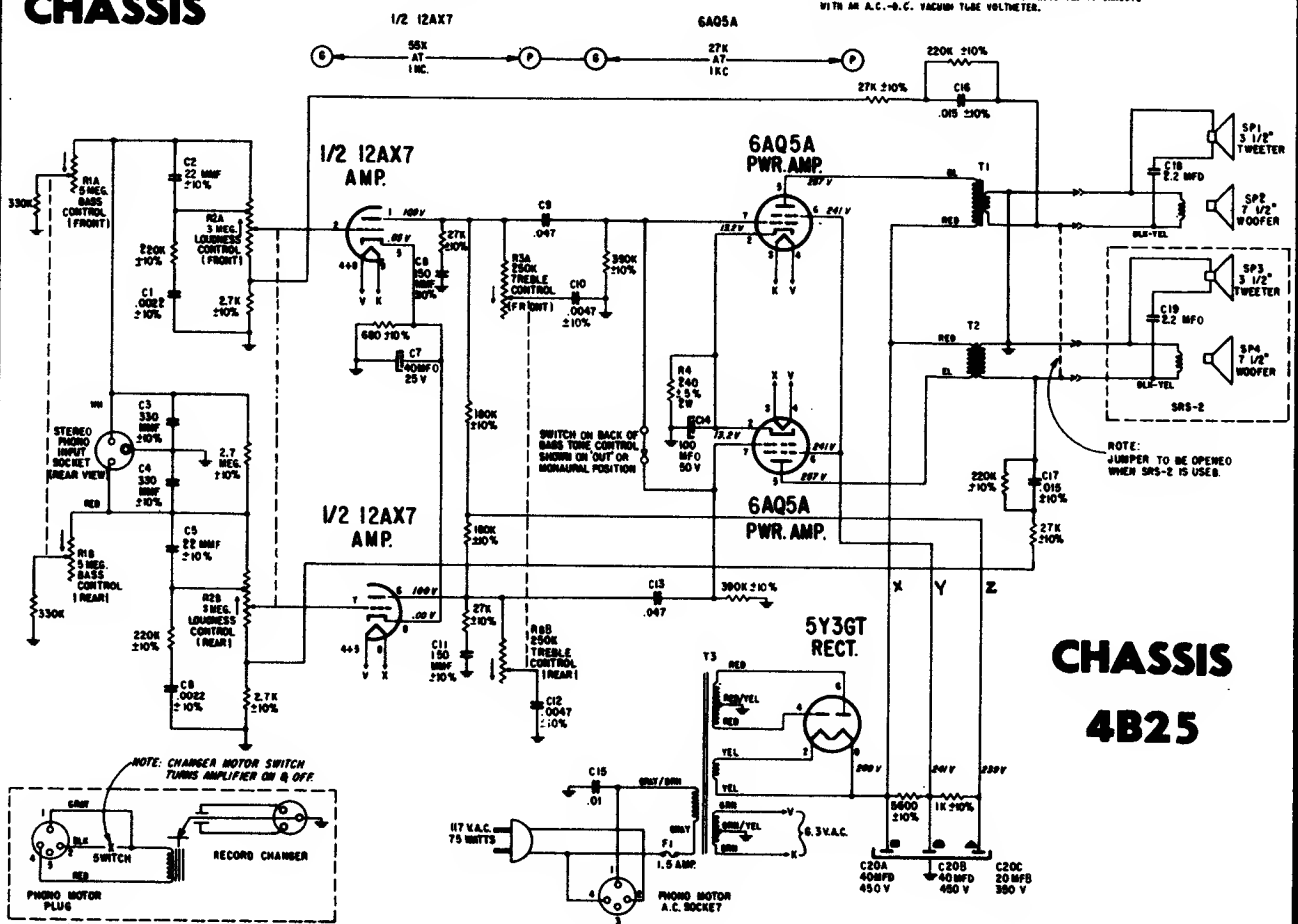

CHASSIS 4B25

ZENITH RADIO CORPORATION MODEL B513Y, L, F, V, CHASSIS 5B01

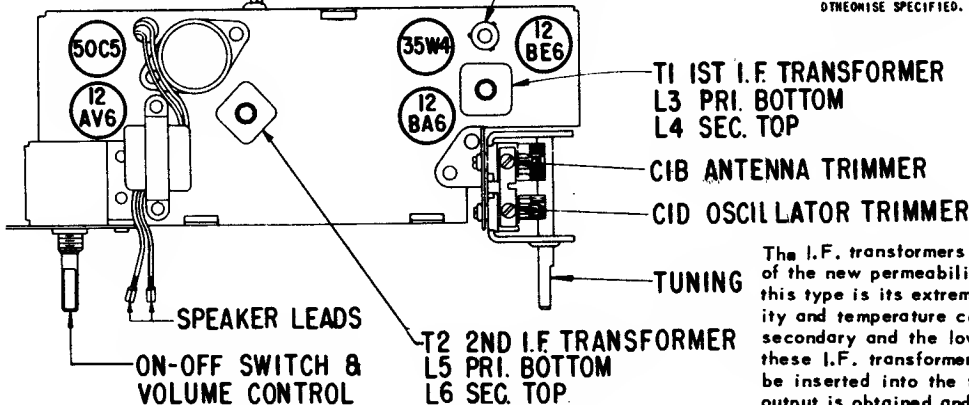
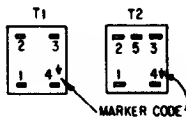
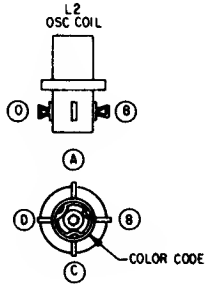
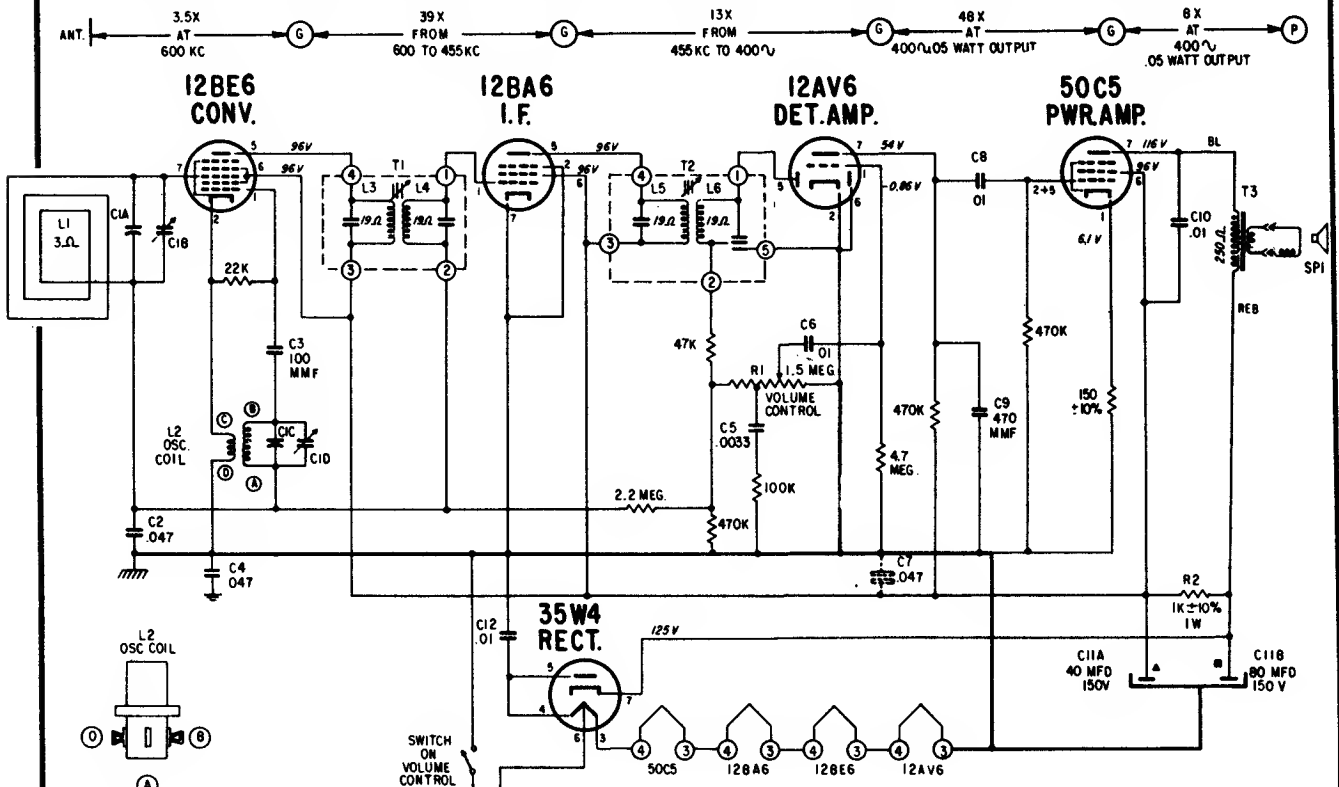

NOTES:

ALL VOLTAGES MEASURED FROM COMMON RETURN TO POINTS INDICATED WITH AN A.C., D.C. OR VACUUM TUBE VOLTMETER.

USE ONLY ZENITH NON-INDUCTIVE ELECTROLYTIC CONDENSERS FOR REPLACEMENT.

IF ANY OTHER TYPE OF ELECTROLYTIC IS USED IT WILL BE NECESSARY TO ADD C7 SHOWN IN DOTTED LINES.

I.F. TRANSFORMER NUMBERING STARTS WITH P1 TERMINAL AS FIRST TERMINAL CLOCKWISE FROM MARKER CODE TERMINAL AS VIEWED FROM BOTTOM OF CHASSIS.

I.F. FREQUENCY 455 KC TUNING RANGE 535-1620 KC

ALL RESISTORS ± 20% TOLERANCE, 1/2 WATT, CARBON UNLESS OTHERWISE SPECIFIED.

The I.F. transformers incorporated in this receiver are of the new permeability tuned type. The advantage of this type is its extreme stability under various humidity and temperature conditions. The upper coil is the secondary and the lower the primary. When adjusting these I.F. transformers, the tuning wrench 68-19 can be inserted into the top slug, rotated until maximum output is obtained and then dropped down to the lower slug and the same operation repeated.

ALIGNMENT PROCEDURE

OPERATION	CONNECT OSCILLATOR TO	DUMMY ANTENNA	INPUT SIG. FREQUENCY	SET DIAL AT	TRIMMERS	PURPOSE
1	Converter Grid	.5 Mfd.	455 Kc.	600 Kc.	L3,L4,L5,L6	Align I.F. for max. output.
2	One Turn Loop Coupled Loosely to Wave Magnet.	-	1600 Kc.	1600 Kc.	C1D	Set Osc. to Dial Scale.
3		-	1400 Kc.	1400 Kc.	C1B	Align Antenna Stage.

VOLUME R-19, MOST-OFTEN-NEEDED 1959 RADIO SERVICING INFORMATION

ZENITH RADIO CORP MODELS B514F,W,C,V-B515B,P,G,Y CHASSIS 5B04-5B06

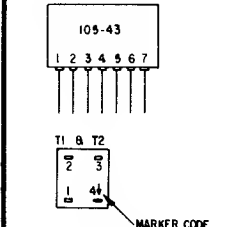
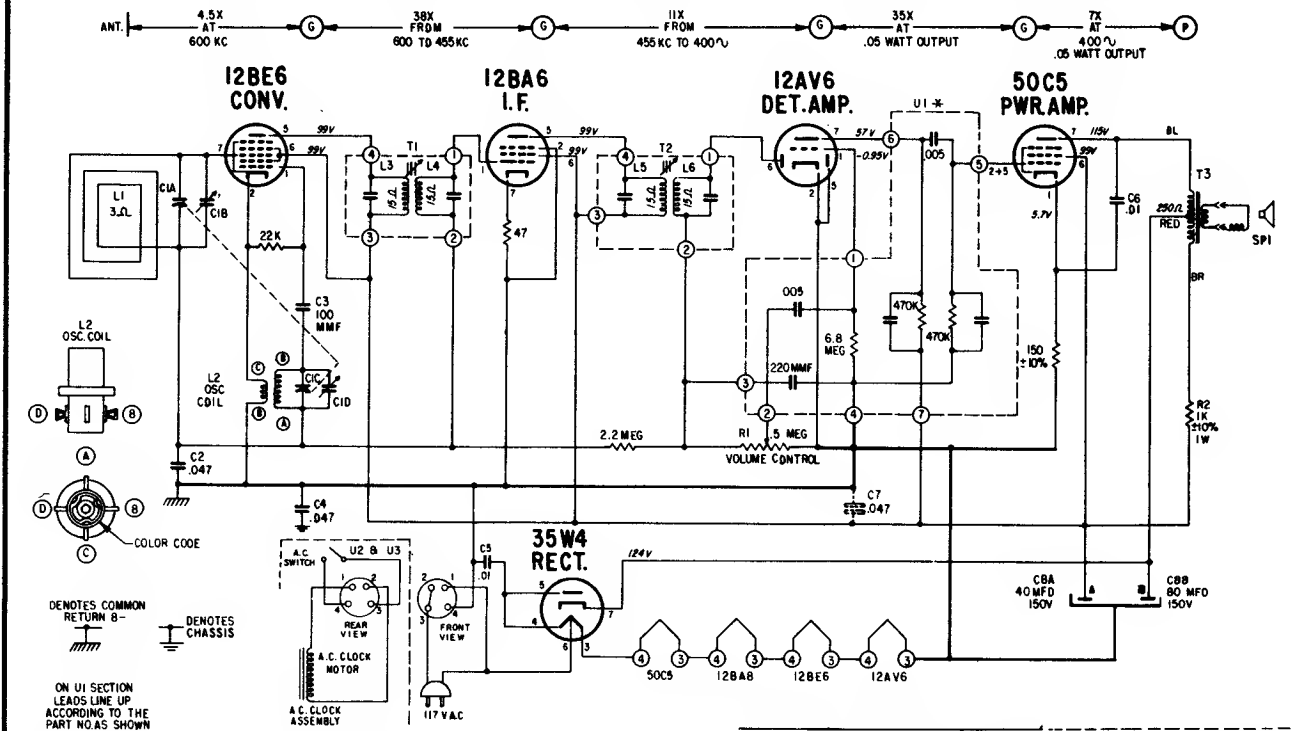

NOTES:
 ALL VOLTAGES MEASURED FROM COMMON RETURN TO POINTS INDICATED WITH AN A.C., D.C. OR VACUUM TUBE VOLTMETER.
 USE ONLY ZENITH NON-INDUCTIVE ELECTROLYTIC CONDENSERS FOR REPLACEMENT.
 IF ANY OTHER TYPE OF ELECTROLYTIC IS USED IT WILL BE NECESSARY TO ADD C7 SHOWN IN DOTTED LINES.
 I.F. TRANSFORMER NUMBERING STARTS WITH #1 TERMINAL AS FIRST TERMINAL CLOCKWISE FROM MARKER CODE TERMINAL AS VIEWED FROM BOTTOM OF CHASSIS.
 I.F. FREQUENCY 455 KC
 TUNING RANGE 535-1620 KC
 ALL RESISTORS ±20% TOLERANCE, 1/2 WATT, CARBON UNLESS OTHERWISE SPECIFIED.

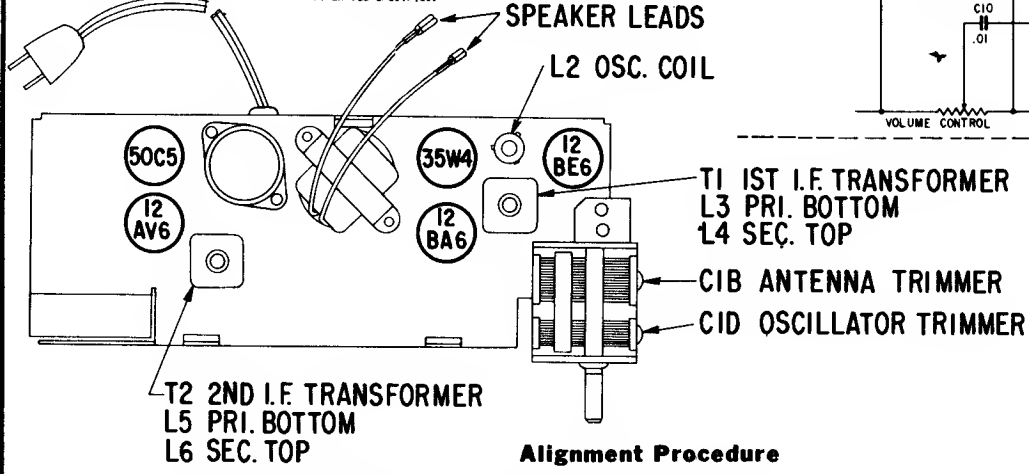
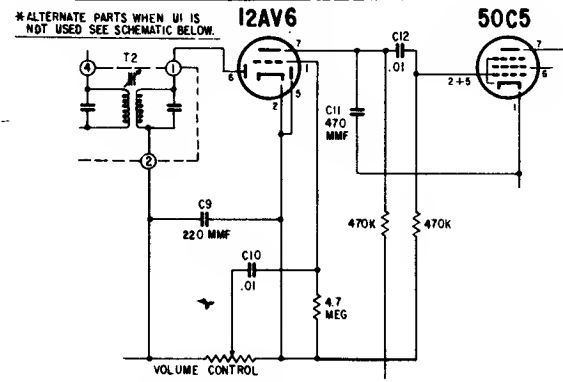

Alignment Procedure

OPERATION	CONNECT OSCILLATOR TO	DUMMY ANTENNA	INPUT SIG. FREQUENCY	SET DIAL AT	TRIMMERS	PURPOSE
1	Converter Grid	.5 Mfd.	455 Kc.	600 Kc.	L3, 4, 5, 6	For I.F. Alignment.
2	One Turn Loop Coupled Loosely to Wave Magnet	—	1600 Kc.	1600 Kc.	CID	Set Oscillator to Dial Scale
3		—	1400 Kc.	1400 Kc.	CIB	Align Antenna Stage

ZENITH RADIO CORPORATION MODELS B509C, P, V, F, CHASSIS 5B11.
 MODELS B511 B, P, L, V, CHASSIS 5B10, are electrically the same.

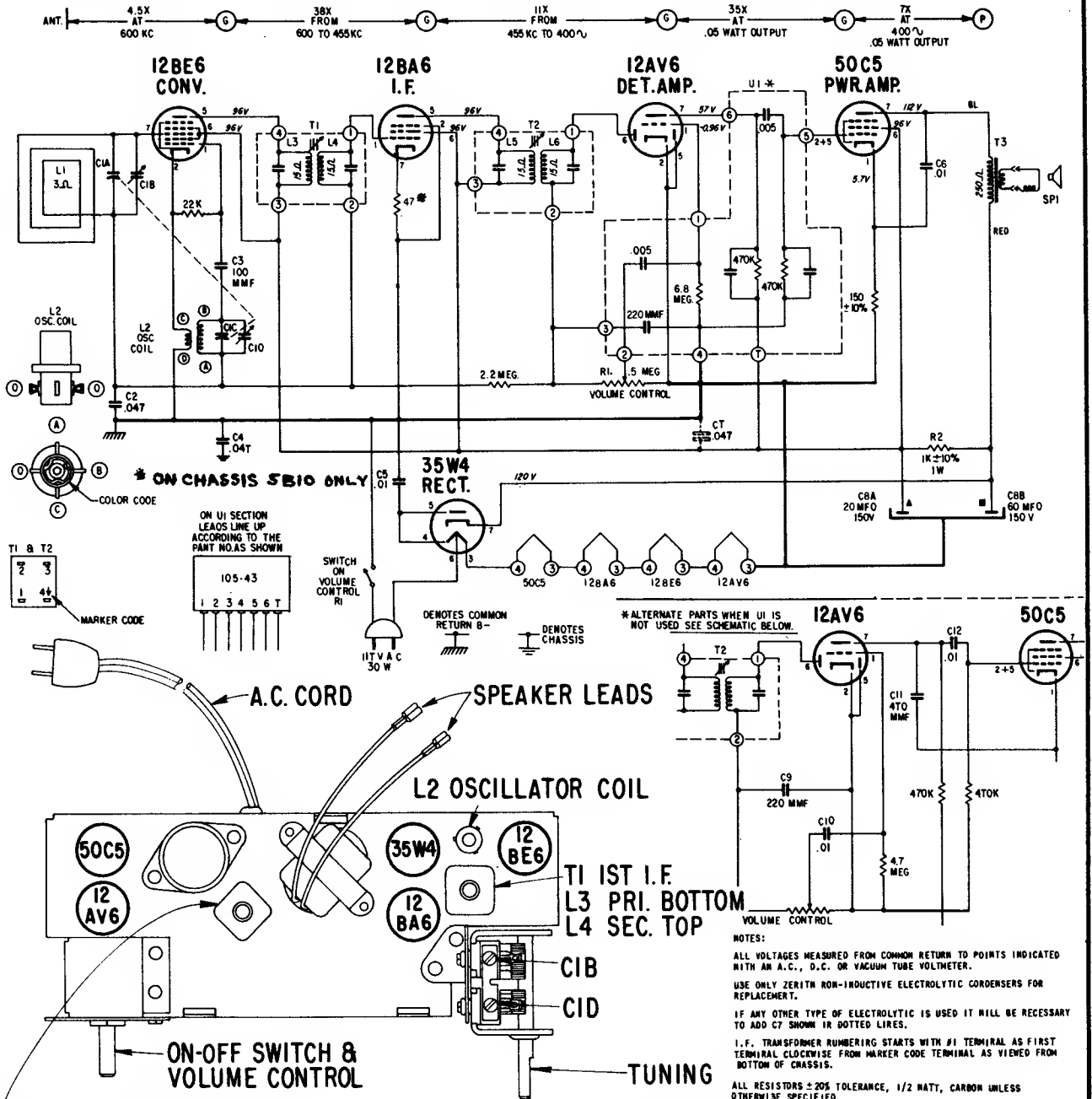

ALIGNMENT PROCEDURE

Operation	Connect Oscillator To	Dummy Antenna	Input Sig. Frequency	Set Dial At	Trimmers	Purpose
1	Converter Grid	.5 Mfd.	455 Kc.	600 Kc.	L3, L4, L5, L6	For I.F. Alignment.
2	One Turn Loop Coupled Loosely to Wave Magnet	—	1600 Kc.	1600 Kc.	C1D	Set Oscillator to Dial Scale
3		—	1400 Kc.	1400 Kc.	C1B	Align Antenna Stage

ZENITH RADIO CORPORATION

MODELS HF116E & HF116R

CHASSIS 5B20

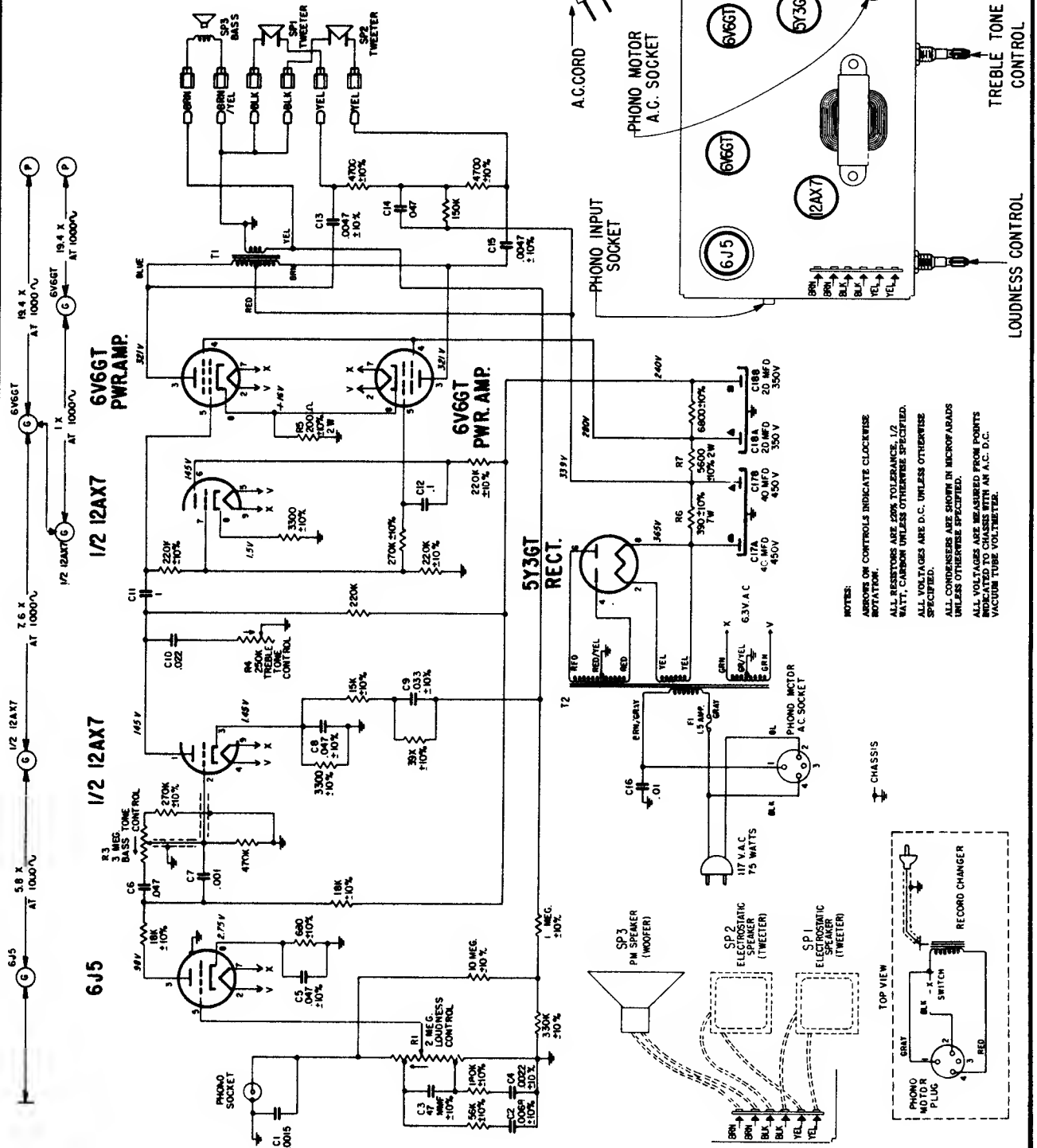

NOTES:
 ARROWS ON CONTROLS INDICATE CLOCKWISE ROTATION.
 ALL RESISTORS ARE 20% TOLERANCE, 1/2 WATT, CARBON UNLESS OTHERWISE SPECIFIED.
 ALL VOLTAGES ARE D.C. UNLESS OTHERWISE SPECIFIED.
 ALL CONDENSERS ARE SHOWN IN MICROFARADS UNLESS OTHERWISE SPECIFIED.
 ALL VOLTAGES ARE MEASURED FROM POINTS INDICATED TO CHASSIS WITH AN A.C. D.C. VACUUM TUBE VOLTMETER.

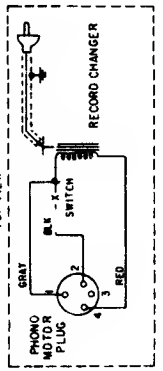

ZENITH RADIO CORPORATION

MODELS SRS10 & SRS15

CHASSIS 5B24

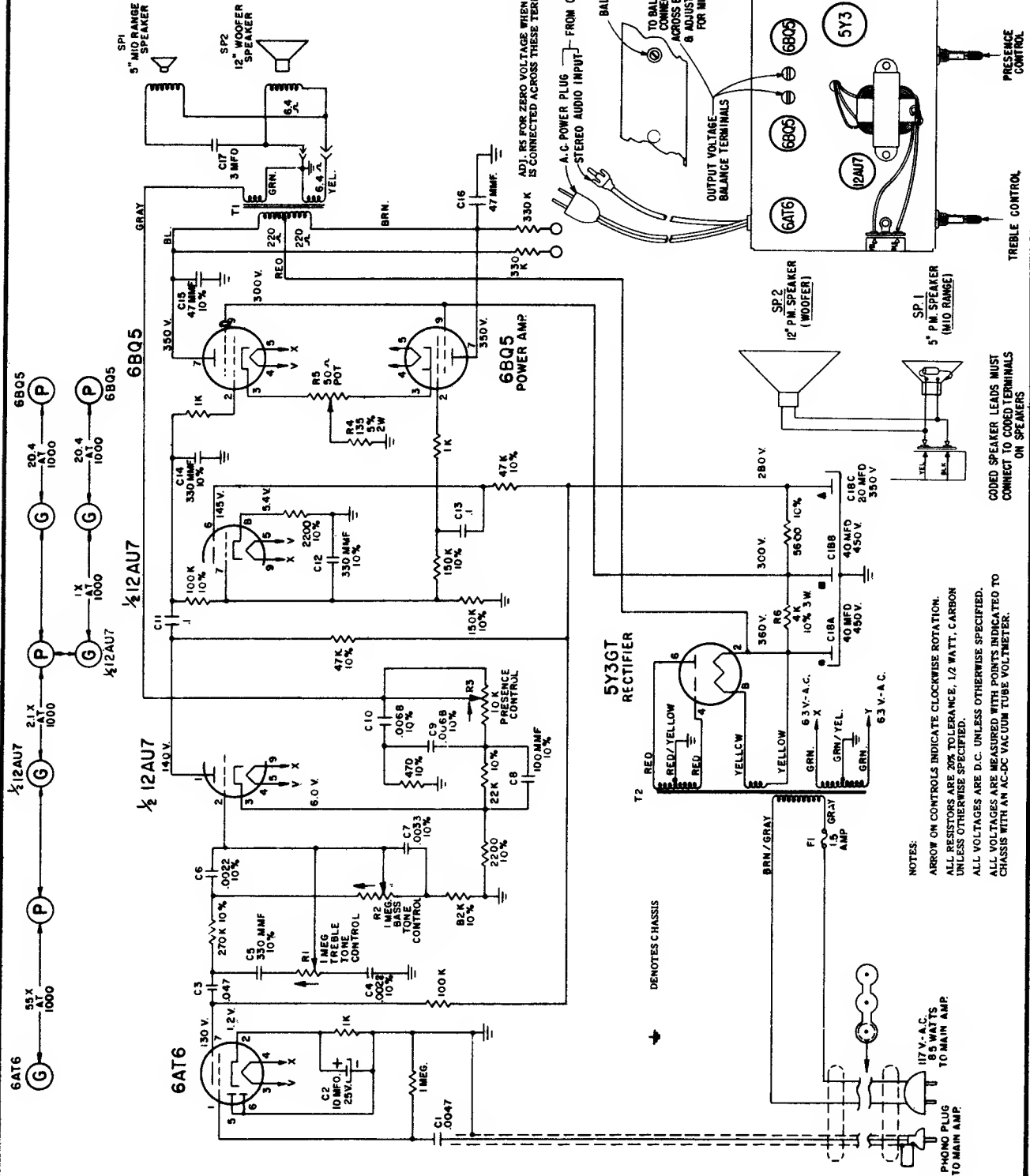

- 6AT6 (G) 55X AT 1000
- 1/2 12AU7 (G) 2.1X AT 1000
- 1/2 12AU7 (P) 1X AT 1000
- 1/2 12AU7 (G) 20.4 AT 1000
- 6BQ5 (P) 20.4 AT 1000
- 6BQ5 (P) 20.4 AT 1000

PHONO PLUG TO MAIN AMP.
117 V.-A.C. 85 WATTS TO MAIN AMP.

TO BALANCE 6BQ5 OUTPUT CONNECT A D.C. VOLTMETER ACROSS BALANCE TERMINALS & ADJUST BALANCE CONTROL FOR MINIMUM VOLTAGE.

A.C. POWER PLUG STEREO AUDIO INPUT FROM CONTROL AMPLIFIER

ADJ. R5 FOR ZERO VOLTAGE WHEN VACUUM TUBE VOLTMETER IS CONNECTED ACROSS THESE TERMINALS.

FUSE

CODED SPEAKER LEADS MUST CONNECT TO CODED TERMINALS ON SPEAKERS

6.0 V.

300 V.

350 V.

350 V.

350 V.

350 V.

350 V.

350 V.

350 V.

350 V.

350 V.

350 V.

NOTES:
ARROW ON CONTROLS INDICATE CLOCKWISE ROTATION.
ALL RESISTORS ARE 20% TOLERANCE, 1/2 WATT, CARBON UNLESS OTHERWISE SPECIFIED.
ALL VOLTAGES ARE D.C. UNLESS OTHERWISE SPECIFIED.
ALL VOLTAGES ARE MEASURED WITH POINTS INDICATED TO CHASSIS WITH AN AC-DC VACUUM TUBE VOLTMETER.

ZENITH RADIO CORPORATION MODELS B615L, F, G CHASSIS 6B05

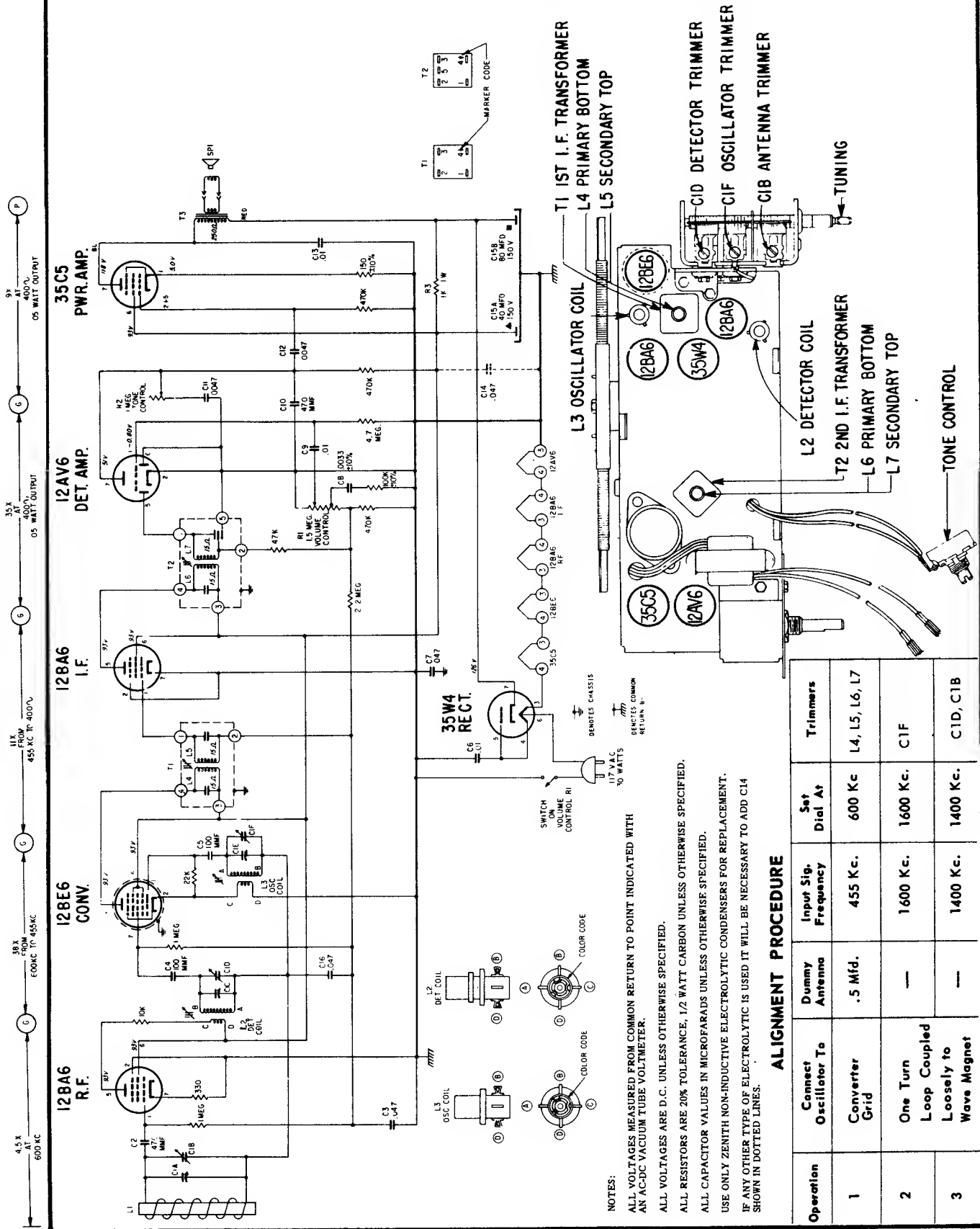

NOTES:
 ALL VOLTAGES MEASURED FROM COMMON RETURN TO POINT INDICATED WITH AN AC-DC VACUUM TUBE VOLTMETER.
 ALL VOLTAGES ARE D.C. UNLESS OTHERWISE SPECIFIED.
 ALL RESISTORS ARE 20% TOLERANCE, 1/2 WATT CARBON UNLESS OTHERWISE SPECIFIED.
 ALL CAPACITOR VALUES IN MICROFARADS UNLESS OTHERWISE SPECIFIED.
 USE ONLY ZENITH NON-INDUCTIVE ELECTROLYTIC CONDENSERS FOR REPLACEMENT.
 IF ANY OTHER TYPE OF ELECTROLYTIC IS USED IT WILL BE NECESSARY TO ADD C14 SHOWN IN DOTTED LINES.

ALIGNMENT PROCEDURE

Operation	Connect Oscillator To	Dummy Antenna	Input Sig. Frequency	Set Dial At	Trimmers
1	Converter Grid	.5 Mfd.	455 Kc.	600 Kc.	L4, L5, L6, L7
2	One Turn Loop Coupled Loosely to Wave Magnet	—	1600 Kc.	1600 Kc.	C1F
3	—	—	1400 Kc.	1400 Kc.	C1D, C1B

Zenith Radio Corporation Model HF660, Chassis 6B06

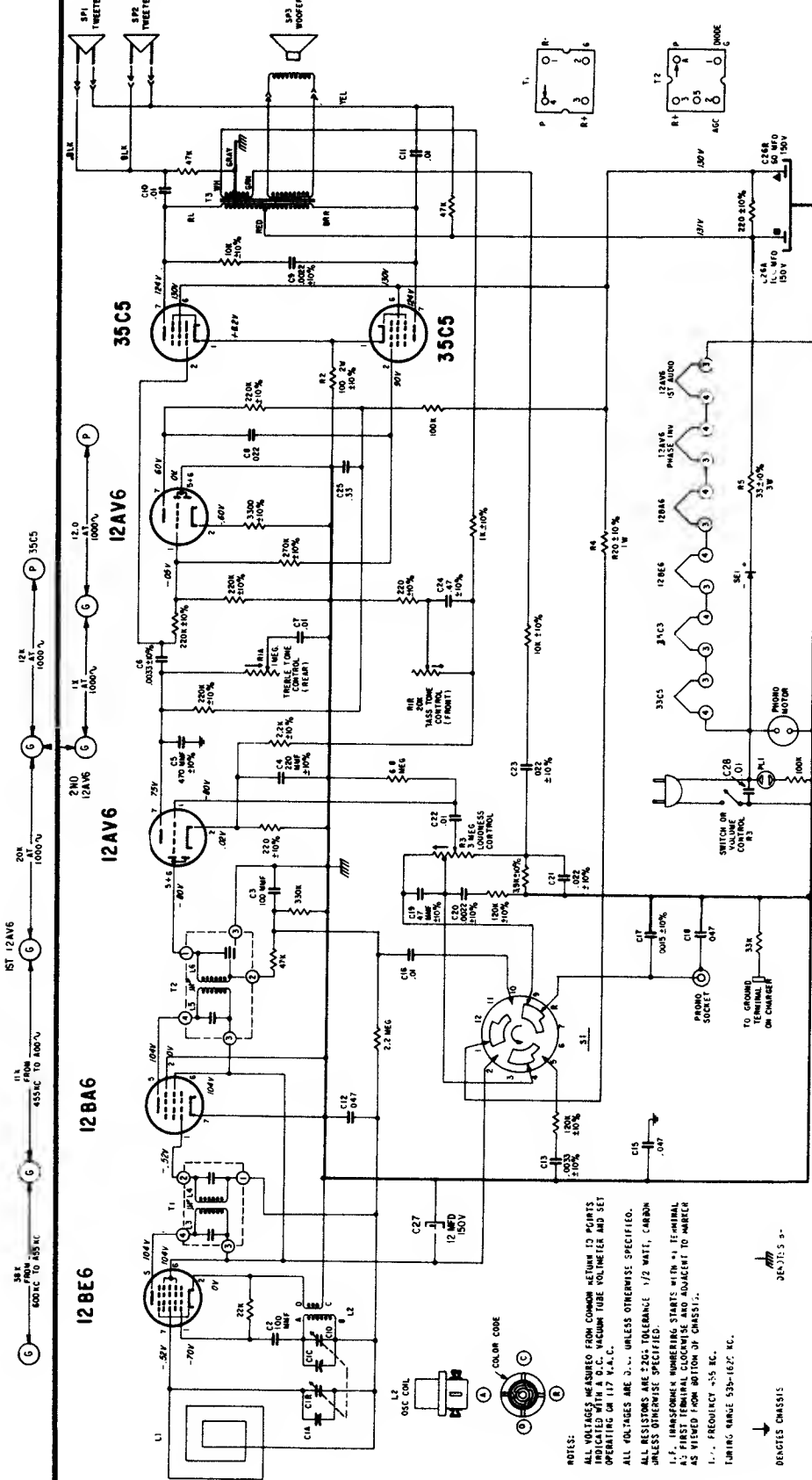

The I. F. transformers incorporated in this receiver are of the new permeability tuned type. The advantage of an I.F. transformer of this type is its extreme stability under various humidity and temperature conditions. The upper coil is the secondary and the lower the primary. When adjusting these I.F. transformers, the tuning wrench 68-19 can be inserted into the top slug, rotated until maximum output is obtained and then dropped down to the lower slug and the same operation repeated. The tuning wrench is so designed that turning one slug does not affect the adjustment of the other.

ALIGNMENT PROCEDURE

OPERATION	CONNECT DUMMY DISCALCULATOR TO ANTENNA	DUMMY ANTENNA	INPUT SIG. FREQUENCY	SET DIAL AT	TRIMMERS	PURPOSE
1	Converter Grid	.5 MFD.	455 Kc.	600 Kc.	L3, L4, L5, L6	Align I.F. for maximum output
2	One Turn Loop Coupled Loosely to Wave Magnet	—	1600 Kc.	1600 Kc.	C1D	Set Oscillator to Dial Scale.
3	—	—	1400 Kc.	1400 Kc.	C1B	Align Antenna Stage

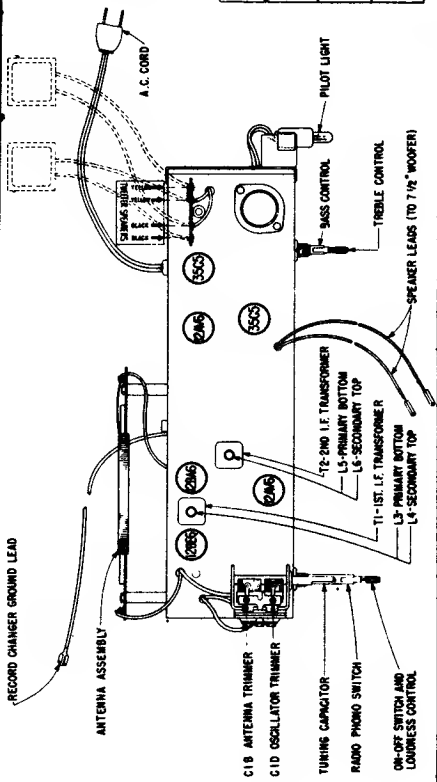

NOTES:
 ALL VOLTAGES MEASURED FROM COMMON RETURN TO POINTS INDICATED WITH A D.C. VACUUM TUBE VOLTMETER AND SET OPERATING AT 117 V.A.C.
 ALL VOLTAGES ARE ±2% UNLESS OTHERWISE SPECIFIED.
 ALL RESISTORS ARE 20% UNLESS OTHERWISE SPECIFIED.
 I.F. TRANSFORMER NUMBERING STARTS WITH "A" IF CENTRAL AS VIEWED FROM BOTTOM OF CHASSIS.
 L.F. FREQUENCY ±5% RC.
 TUNING RANGE 530-1625 KC.

ZENITH RADIO CORPORATION

MODELS BP6B, L, V

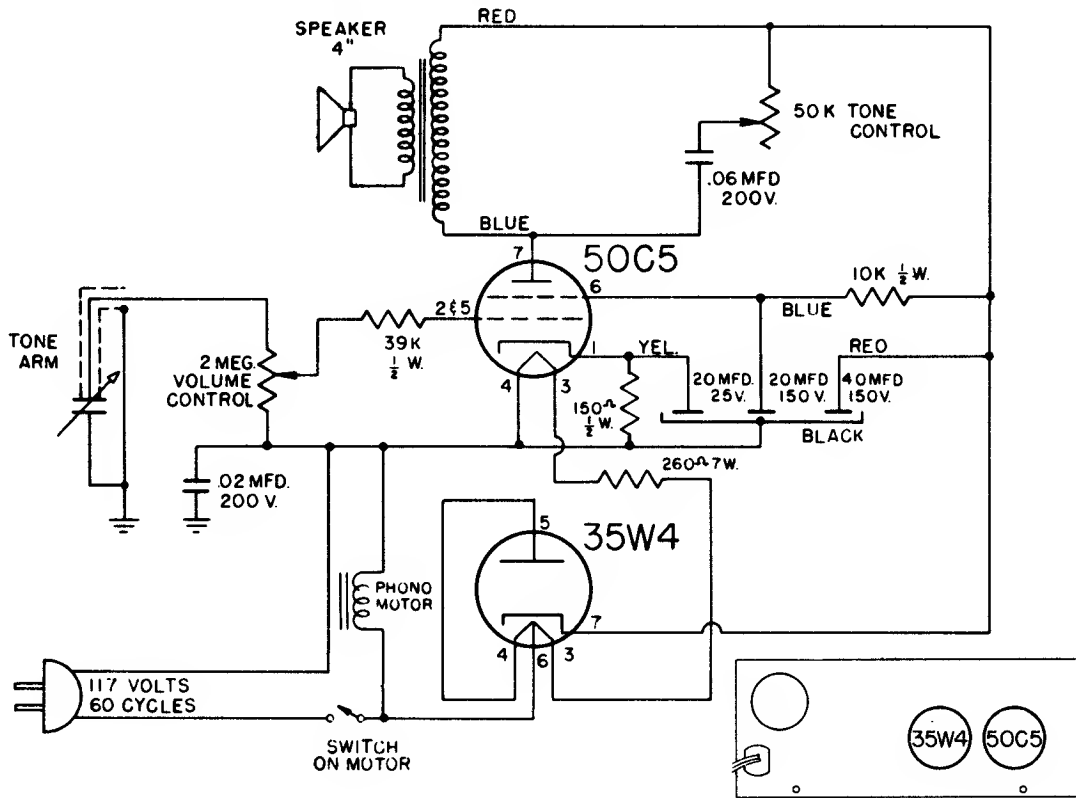

MODEL BP7F

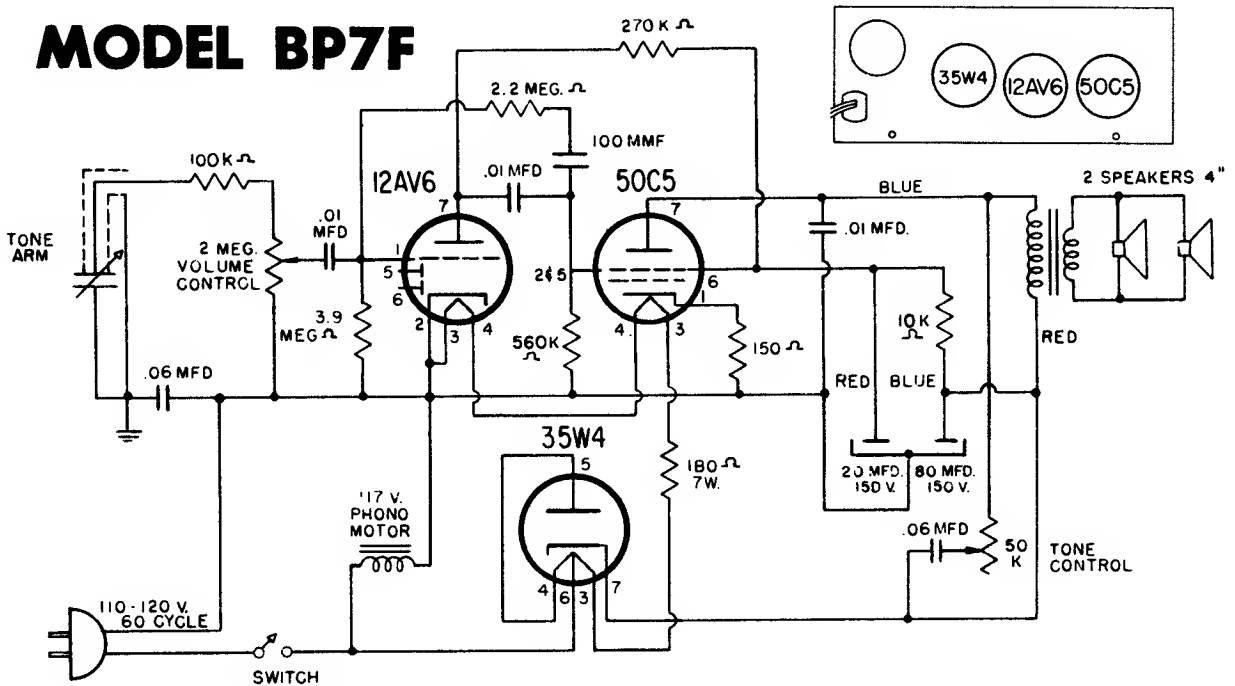

ZENITH RADIO CORP.
 Model B728C, -F, -W, Chassis 7A03
 (Continued from page 182)

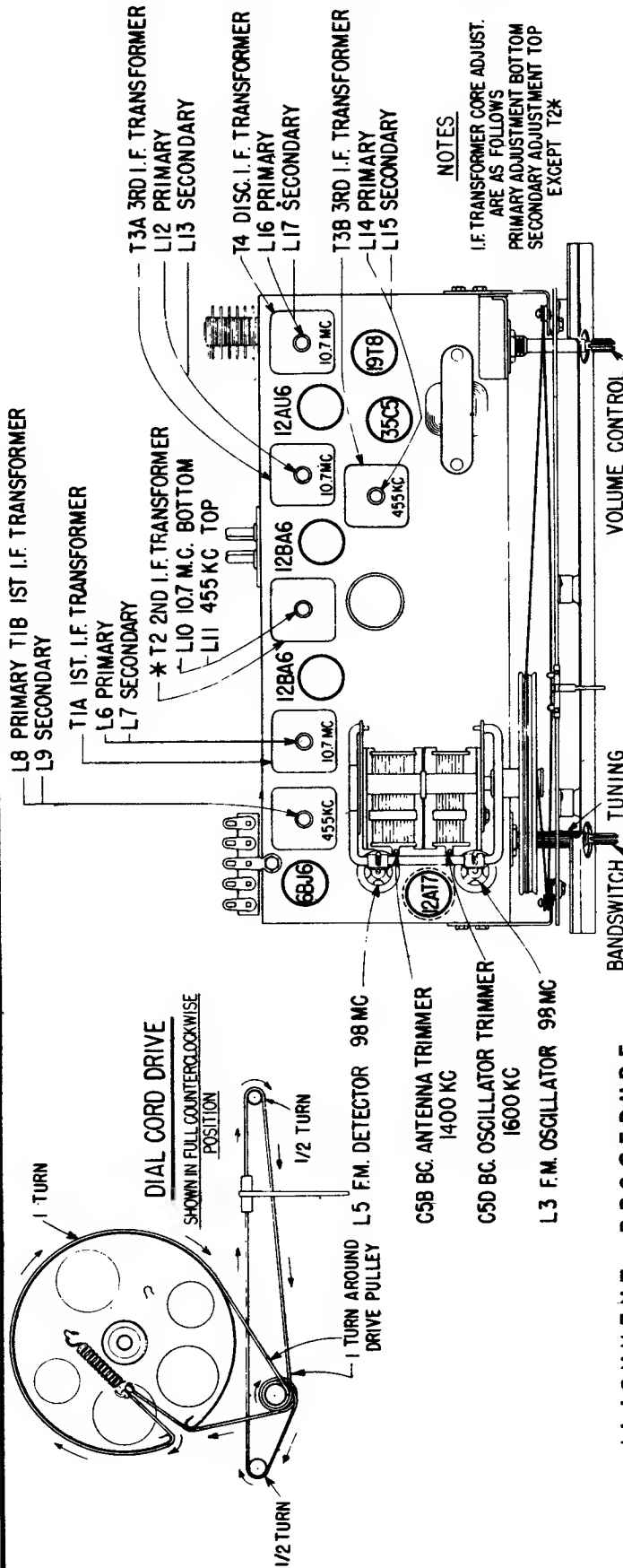

ALIGNMENT PROCEDURE

OPERATION	CONNECT OSCILLATOR TO	DUMMY ANTENNA	INPUT SIGNAL FREQUENCY	BAND	SET DIAL TO	ADJ. TRIMMERS	PURPOSE
1	Pin 2 12AT7 Converter	.05 Mfd.	455 Kc. Modulated.	BC	600 Kc.	L8, 9, 11, 14, 15	Align I.F. channel for maximum output.
2	2 turns loosely coupled to wavemagnet		1600 Kc. Modulated.	BC	1600 Kc.	C5D	Set oscillator to dial scale.
3	2 turns loosely coupled to wavemagnet		1400 Kc. Modulated.	BC	1400 Kc.	C5B	Align antenna stage
4 (a)	Pin 1 (grid) on 12AU6 limiter	.05 Mfd.	10.7 Mc. Unmodulated.	FM		L16 coil slug Primary discr.	Align primary of discriminator for maximum reading.
5 (b)	Pin 1 (grid) on 12AU6 limiter	.05 Mfd.	10.7 Mc. Unmodulated.	FM		L17 coil slug sec. of discr.	Adjust secondary of discriminator for zero reading.
6 (c)	Pin 1 (grid) on 12BA6 2nd IF.	.05 Mfd.	10.7 Mc. Unmodulated.	FM		L12 & L13 Prim. & Sec. of 3rd IF trans.	Align 3rd IF transformer for maximum reading.
7 (c)	Pin 1 (grid) on 12BA6 1st IF.	.05 Mfd.	10.7 Mc. Unmodulated.	FM		L10 Prim. of 2nd IF transformer.	Align 2nd IF transformer for maximum reading.
8 (c)	Pin 2 (grid) on 12AT7 converter tube socket	.05 Mfd.	10.7 Mc. Unmodulated.	FM		L6 & L7 Prim. & Sec. of 1st IF trans.	Align 1st IF transformer for maximum reading.
9 (c)	Antenna Post FM (Remove line ant.)	270 ohms	98 Mc. Unmodulated.	FM	98 Mc.	L3 Osc. Coil Slug	Set Oscillator to dial scale.
10 (c) (d)		270 ohms	98 Mc. Unmodulated.	FM	98 Mc.	L5 Det. Coil Slug	Align det. stage to maximum reading.

SCHEMATIC DIAGRAM FOR 7AT48Z

VOLUME R-19, MOST-OFTEN-NEEDED 1959 RADIO

ZENITH RADIO Model "ROYAL 200"
Chassis 7AT48Z, 7AT48Z2, 7AT48Z4

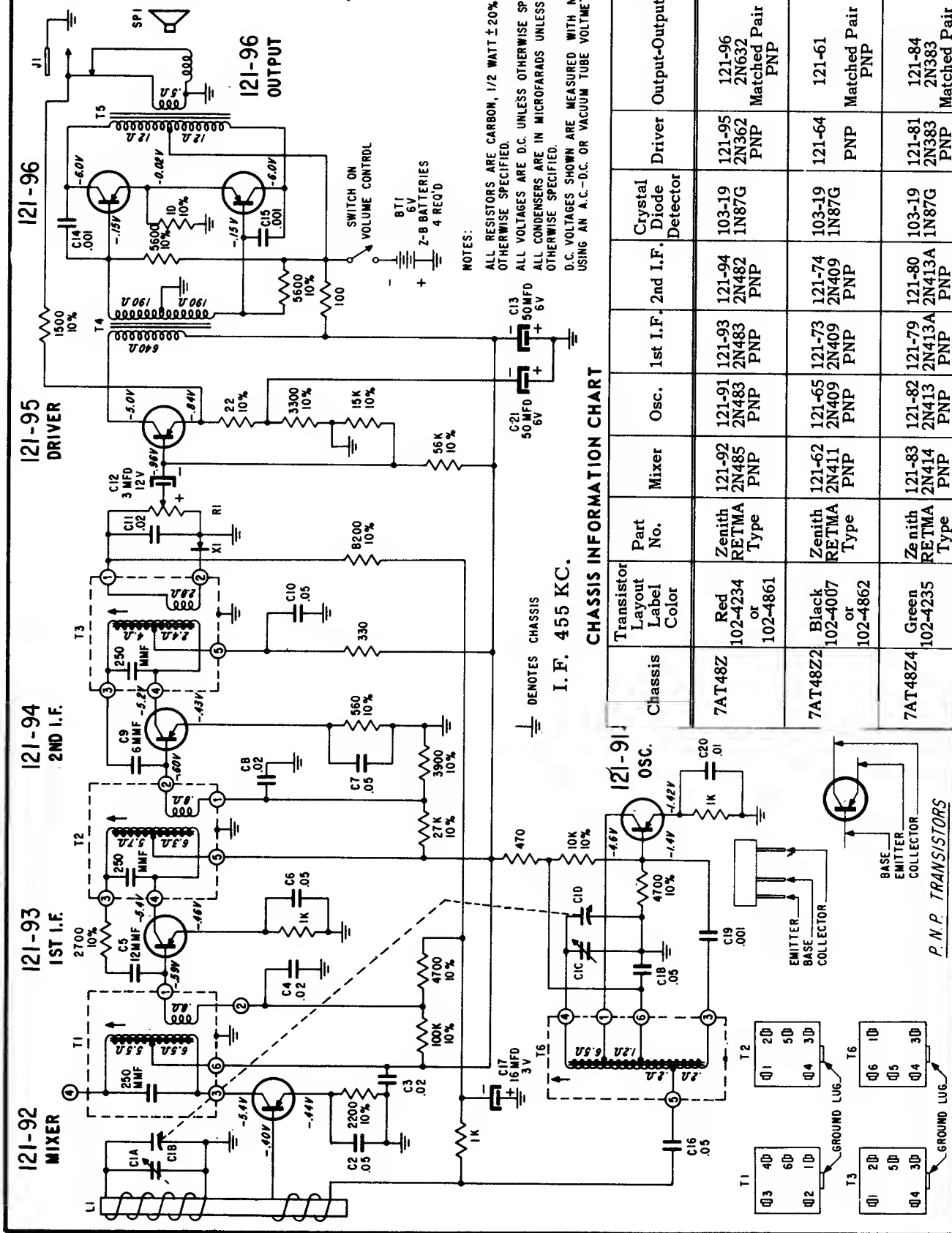

NOTES:
ALL RESISTORS ARE CARBON, 1/2 WATT ± 20% UNLESS OTHERWISE SPECIFIED.
ALL VOLTAGES ARE D.C. UNLESS OTHERWISE SPECIFIED.
ALL CONDENSERS ARE IN MICROFARADS UNLESS OTHERWISE SPECIFIED.
D.C. VOLTAGES SHOWN ARE MEASURED WITH NO SIGNAL USING AN A.C.-D.C. OR VACUUM TUBE VOLTMETER.

CHASSIS INFORMATION CHART

Chassis	Transistor Layout Label Color	Part No.	Mixer	Osc.	1st I.F.	2nd I.F.	Crystal Diode Detector	Driver	Output-Output	Supplier
7AT48Z	Red 102-4234 or 102-4861	Zenith RE7MA Type	121-92 2N485 PNP	121-91 2N483 PNP	121-93 2N483 PNP	121-94 2N482 PNP	103-19 1N87G	121-95 2N362 PNP	121-96 2N632 Matched Pair PNP	Raytheon
7AT48Z2	Black 102-4007 or 102-4862	Zenith RE7MA Type	121-62 2N411 PNP	121-65 2N409 PNP	121-73 2N409 PNP	121-74 2N409 PNP	103-19 1N87G	121-64 PNP	121-61 Matched Pair PNP	R.C.A.
7AT48Z4	Green 102-4235	Zenith RE7MA Type	121-83 2N414 PNP	121-82 2N413 PNP	121-79 2N413A PNP	121-80 2N413A PNP	103-19 1N87G	121-81 2N383 PNP	121-84 2N383 Matched Pair	Tung Sol

P.N.P. TRANSISTORS

ZENITH RADIO

MODEL "ROYAL 450" -- CHASSIS 7AT45Z1

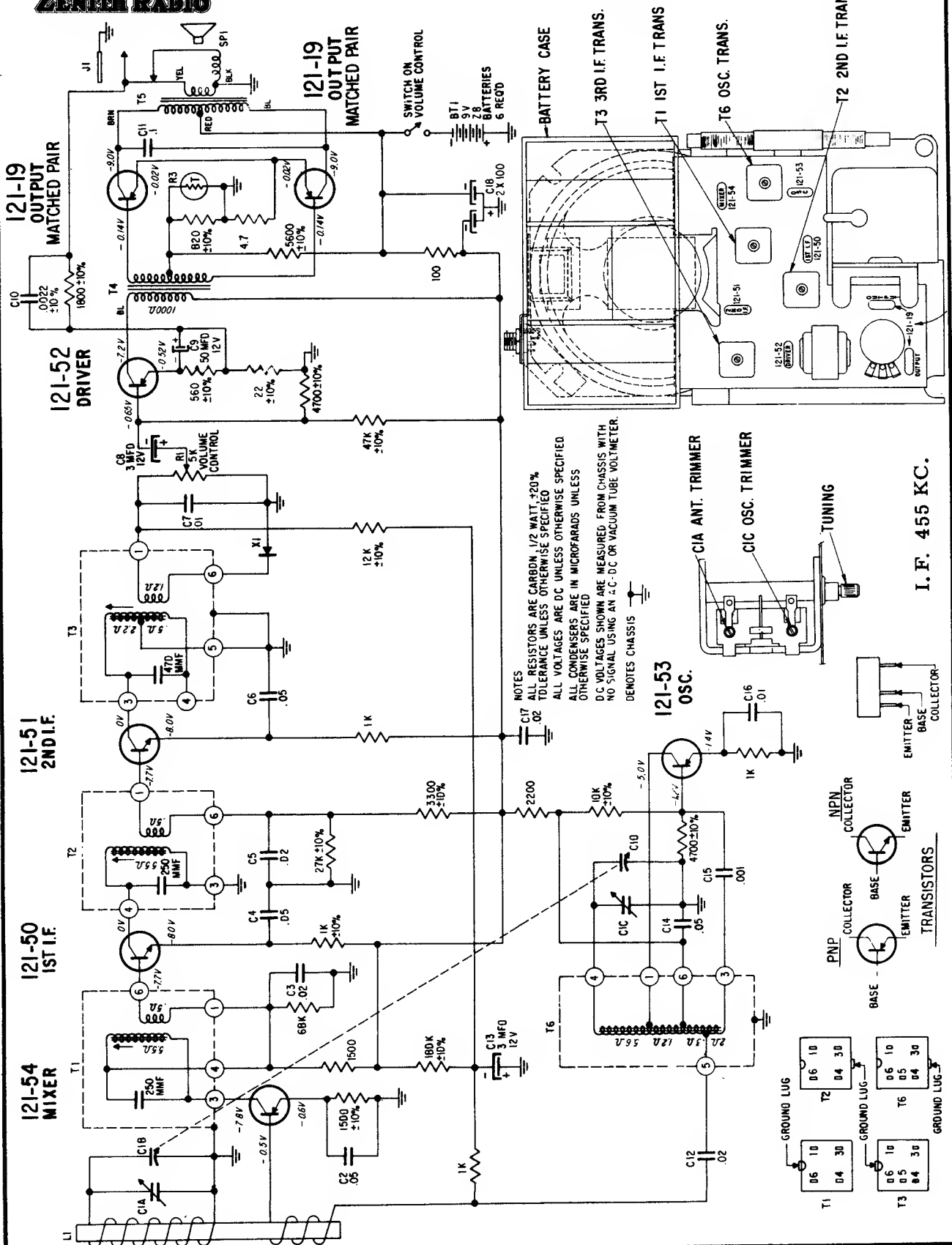

NOTES
 C17 ALL RESISTORS ARE CARBON 1/2 WATT ±20% TOLERANCE UNLESS OTHERWISE SPECIFIED
 ALL VOLTAGES ARE DC UNLESS OTHERWISE SPECIFIED OTHERWISE SPECIFIED
 ALL CONDENSERS ARE IN MICROFARADS UNLESS OTHERWISE SPECIFIED
 D.C. VOLTAGES SHOWN ARE MEASURED FROM CHASSIS WITH NO SIGNAL USING AN A.C. DC OR VACUUM TUBE VOLTMETER.
 DENOTES CHASSIS

I.F. 455 KC.

ZENITH RADIO CORPORATION

Model "Royal 750L" -- Chassis 8AT41Z2

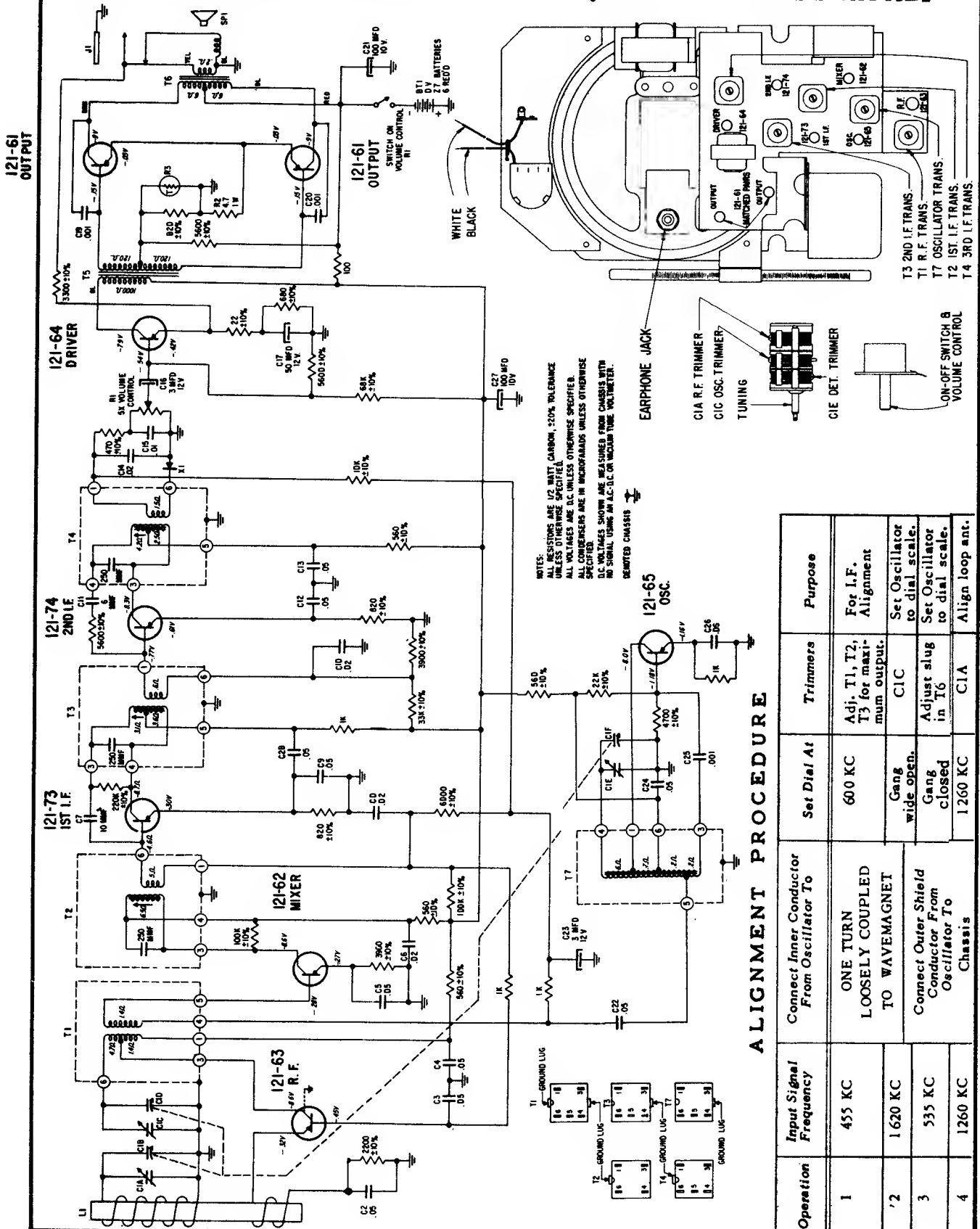

ALIGNMENT PROCEDURE

Operation	Input Signal Frequency	Connect Inner Conductor From Oscillator To	Set Dial At	Trimmers	Purpose
1	455 KC	ONE TURN LOOSELY COUPLED TO WAVEMAGNET	600 KC	Adj. T1, T2, T3 for maximum output.	For I.F. Alignment
2	1620 KC	Connect Outer Shield Conductor From Oscillator To Chassis	Gang wide open.	CIC	Set Oscillator to dial scale.
3	535 KC		Gang closed	Adjust slug in T6	Set Oscillator to dial scale.
4	1260 KC		1260 KC	CIA	Align loop ant.

ZENITH RADIO CORP.

MODEL "ROYAL 760"

RADIO CHASSIS 8AT42Z2

(Alignment information on page 189)

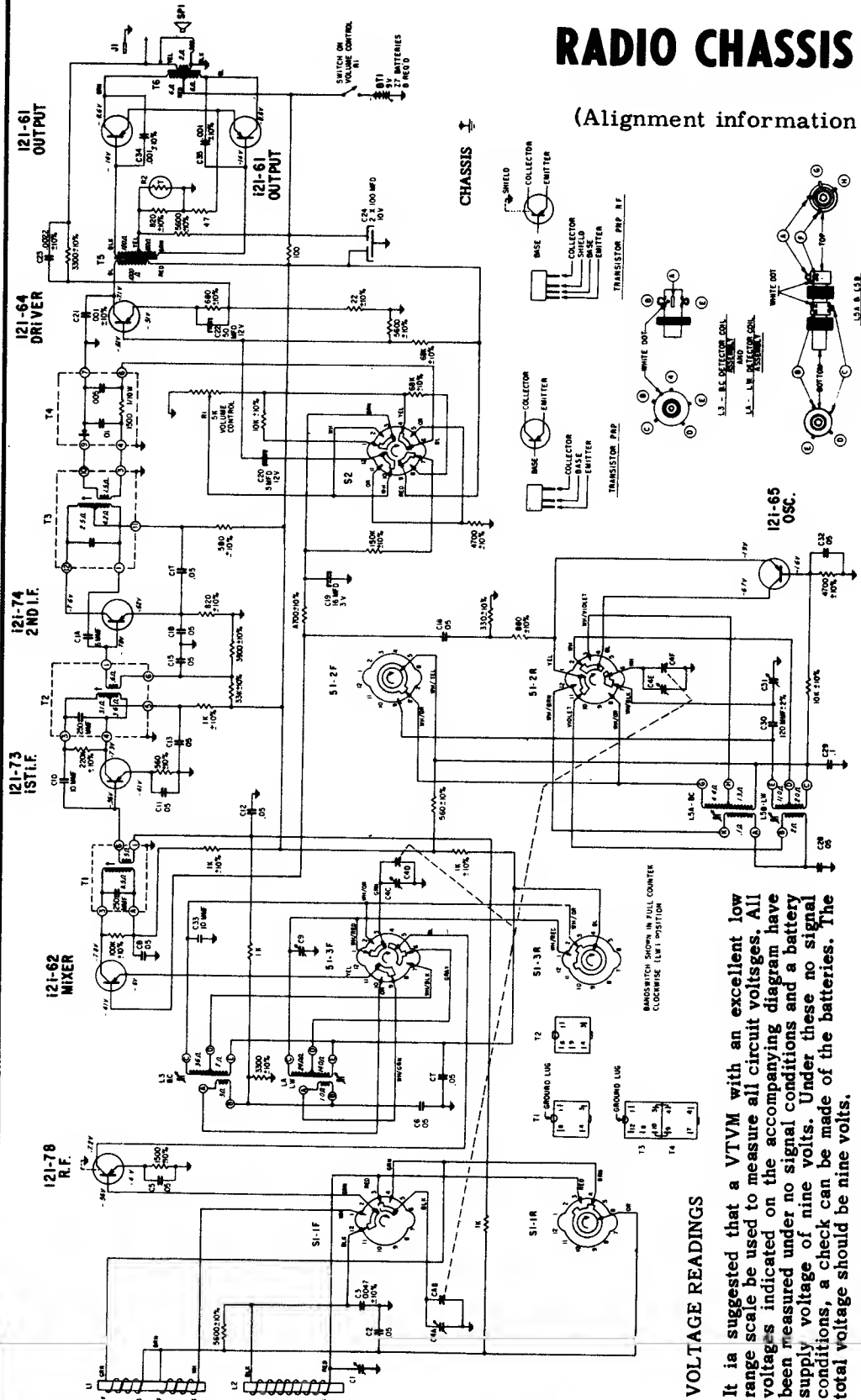

VOLTAGE READINGS

It is suggested that a VTVM with an excellent low range scale be used to measure all circuit voltages. All voltages indicated on the accompanying diagram have been measured under no signal conditions and a battery supply voltage of nine volts. Under these no signal conditions, a check can be made of the batteries. The total voltage should be nine volts.

COMPONENT REPLACEMENT

When soldering components at the base of the transistor socket, it is suggested that the transistor be removed to avoid any possibility of excessive heat being transferred through the socket to the transistor. When soldering the low voltage electrolytic and germanium diodes, it is suggested that the wire be held with a pair of long nose pliers while soldering. The long nose pliers will act as a heat sink.

NOTES:

- ALL RESISTORS ARE 1/2 WATT. CARBON ±20% TOLERANCE UNLESS OTHERWISE SPECIFIED.
- ALL VOLTAGES ARE D.C. UNLESS OTHERWISE SPECIFIED.
- ALL CONDENSERS ARE IN MICROFARADS UNLESS OTHERWISE SPECIFIED.
- D.C. VOLTAGES SHOWN ARE MEASURED FROM CHASSIS WITH BANDSWITCH IN BROADCAST POSITION AND NAVIGATE NORMAL SWITCH IN NORMAL POSITION WITH NO SIGNAL USING AN A.C. D.C. OR VACUUM TUBE VOLTMETER.

ZENITH RADIO CHASSIS 8AT42Z2

MODEL "ROYAL 760"

(Continued from page 188)

ALIGNMENT PROCEDURE

NOTE: Alignment must be made with Nor. - Nav. switch in Nor. position.

OPER.	CONNECT GEN. TD DUMMY ANTENNA	INPUT SIG. FREQUENCY	BAND	SET DIAL AT	TRIMMERS	PURPOSE
1	One turn loop coupled loosely to Broadcast Wavemagnet	455 Kc	BC	1600 Kc	T1, T2, T3	Align I.F.
*2	One turn loop coupled loosely to Broadcast Wavemagnet	600 Kc	BC	600 Kc	Rock Gang, Adjust L5A	Alignment of BC at 600 Kc
3	One	1600 Kc	BC	1600 Kc	C4E	Set osc. to scale
REPEAT OPERATIONS 2 & 3						
4	Turn Loop Coupled	600 Kc	BC	600 Kc	Rock, Adjust L3	Alignment of BC detector at 600 Kc
*5	Loosely to Broadcast Wavemagnet	1400 Kc	BC	1400 Kc	C4C	Alignment BC detector
REPEAT OPERATIONS 5 & 6						
8	Broadcast Wavemagnet	1400 Kc	BC	1400 Kc	C4A	Alignment of BC antenna
*9	One turn coupled loosely to Long Wave Wavemagnet	165 Kc	LW	165 Kc	Rock Gang, Adjust L5B	Alignment of LW at 165 Kc
*10	One	400 Kc	LW	400 Kc	C31	Set osc. to scale
REPEAT OPERATIONS 9 & 10						
11	Turn Loop Coupled	165 Kc	LW	165 Kc	Rock, Adjust L4	Alignment LW detector at 165 Kc
*12	Loosely to Long Wave Wavemagnet	370 Kc	LW	370 Kc	C9	Alignment LW detector
REPEAT OPERATIONS 12 & 13						
14	Long Wave Wavemagnet	370 Kc	LW	370 Kc	C1	Alignment of LW antenna
15						

*NOTE: Rock tuning condensaer when making alignment under Operations 2, 5, 9, 10, 12, 13.

Chassis	Chassis Color Dot	Transistor Layout Color	Part No.	R.F. Type	Mixer	Osc.	1st I.F.	2nd I.F.	Crystal Diode Detector	Driver	Output-Output	Supplier	
8AT42Z2	Black	Black	102-3497	Zenith PNP	121-78 PNP	121-69 PNP	121-65 PNP	121-73 PNP	121-74 PNP	103-22 PNP	121-64 PNP	121-61 PNP	Matched Pair R.C.A.

TRANSISTOR & TRIMMER LAYOUT FOR 8AT42Z2

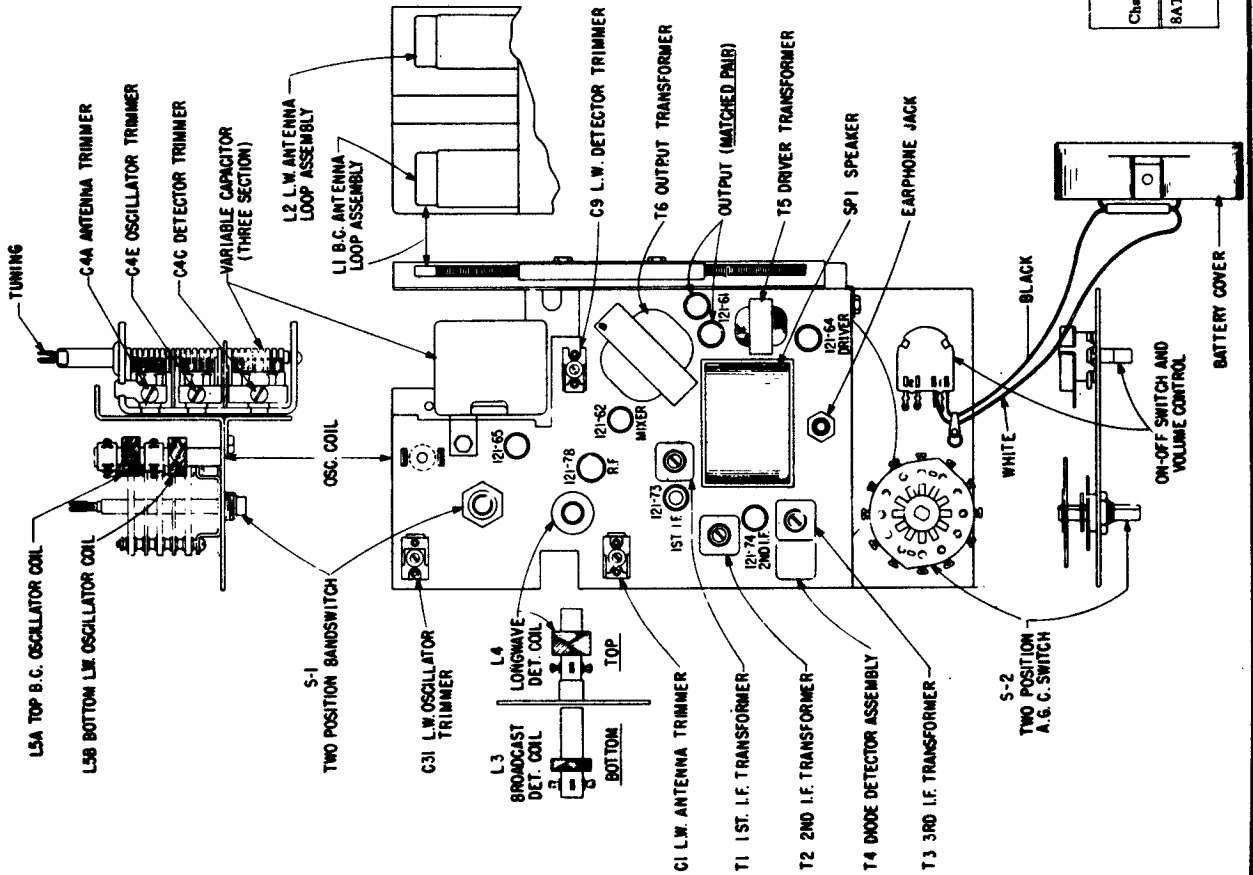

ZENITH RADIO CORP.

CHASSIS 7AT44ZI

MODEL "ROYAL 900"

I. F. 455 KC.

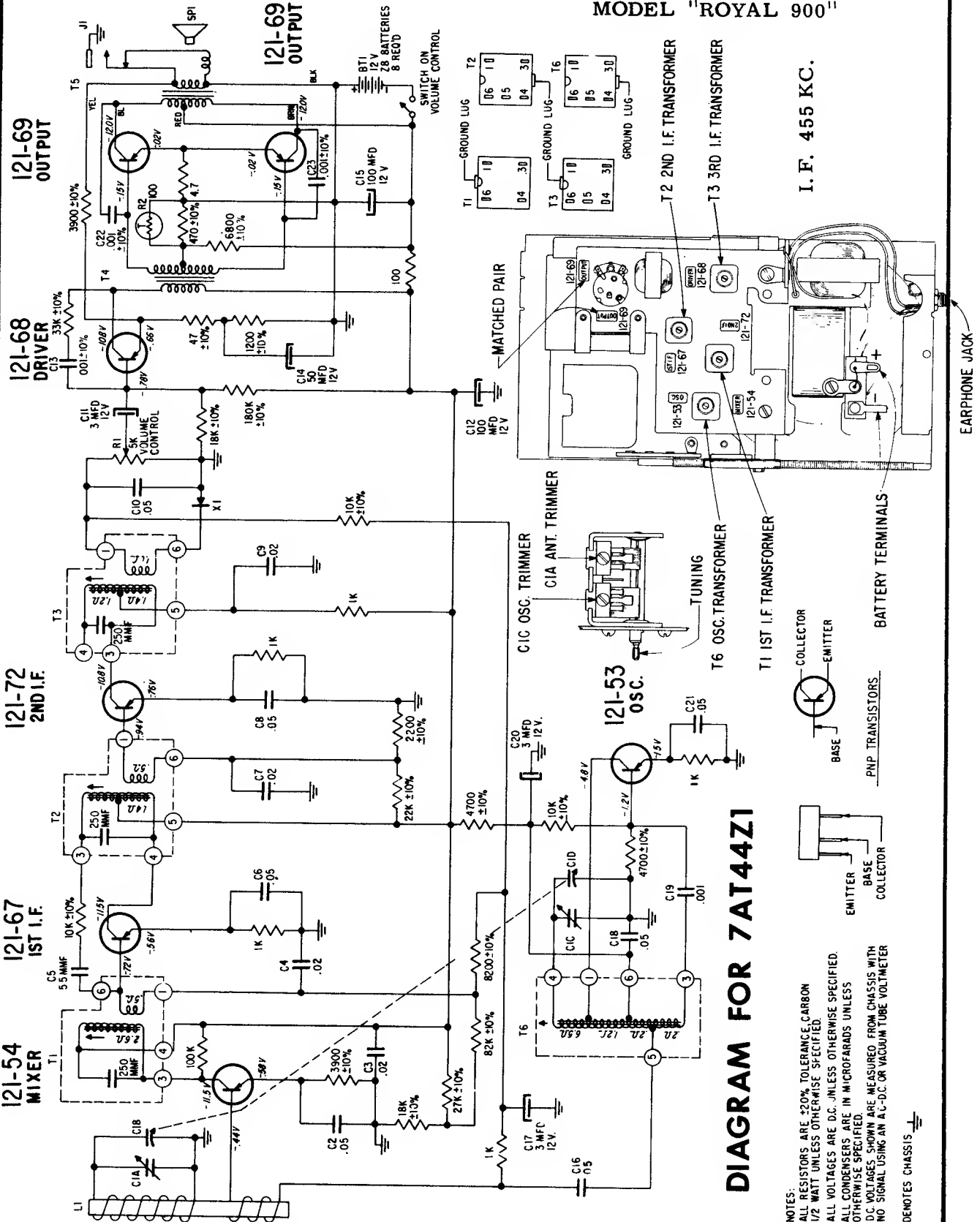
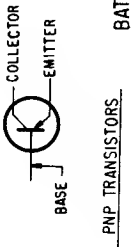

DIAGRAM FOR 7AT44ZI

NOTES:
 ALL RESISTORS ARE .20% TOLERANCE CARBON
 1/2 WATT UNLESS OTHERWISE SPECIFIED.
 ALL VOLTAGES ARE D.C. UNLESS OTHERWISE SPECIFIED.
 ALL CONDENSERS ARE IN MICROFARADS UNLESS
 OTHERWISE SPECIFIED.
 DC VOLTAGES SHOWN ARE MEASURED FROM CHASSIS WITH
 NO SIGNAL USING AN A.C.-D.C. OR VACUUM TUBE VOLTMETER
 DENOTES CHASSIS



Index

Admiral Corp.	Arvin, Cont.	Emerson, Cont.	G E Continued	Motorola, Cont.
4S2 6	8584 16	971, A 37	P715, B, D 50	6X28P, W 80
5T4A 9	1.43700 17	also 38	P716, B, D 50	7X23E 94
5W4 3	1.43800 13	999 36	P725B 51	7X24S, W 94
6T2 4	1.43900 17	999R 36	P726B 51	7X25P, W 91
7N1 6	1.44100 15	120392B 32	P735A 52	8X26E, S 92
7N1A 6	1.44200 15	120394B 33	P736A 52	9AX 65
8M1 5	1.44600 16	120399B 33	P755A 53	BKA9X 66
8S1 8	1.45000 12	120416 34	P805 53	CTA9X 66
8S1A 8	1.45200 14	120430B 33	P806 53	CTM9X 67
12B1, -A 9		120431B 35	RP1110A 55	OEA9X 66
392 6	Buick	120432B 33	RP1120A, B 56	PCA9X 66
393 6	981968 18-19	120433B, R 36	RP1160A 57	SF11B, N 95
462 6-7	981969 30-31	120455B 37	RT1230A 58	SH12E, N, S 96
463 6-7	981970 20-21	120456B 38	RT1231A 58	S21B, + 97
521 4		120459B 37		SK21B, + 97
528 4	Chevrolet	120462B 38	Granco	SK23B, + 97
561 8	987888 22-23	Ford	601 60	93MR 68
566 8	987891 24-25	B9FA-18805E	701 61	94MA 69
581 3	987893 30-31	B9FA-18806B		94MF 70
582 3		B9FA-18806C	Montgomery	94MFM 70
632 9	Delco	pages 70 & 71	Ward	95MF 71
633 9	981968 18-19	General-Elect.	H-667P5 160	300X 72
634 9	981969 30-31	AS2 56	GEN-1115A 62	301X 73
642 9	981970 20-21	AS15A 59	GEN-1116A 62	406 74
643 9	987888 22-23	AS16A 59	GTM-1117A 160	HS-633 78
644 9	987891 24-25	T105A 39	1120A, B 63	HS-637 79
649 9	987893 30-31	T106A, B 39	GEN-1628A 64	HS-638 80
654 9	988976 26-27	T107B 39		HS-647 81
662 9	988977 30-31	T115A 40	Motorola	HS-652 82
663 9	988978 20-21	T116A 40	2F11B, R 87	HS-653 83
664 9	989170 28-29	T120A, B 41	2F12N, W 87	HS-654 83
671 9	989171 30-31	T125A 42	3F13B, W 87	HS-658 84
801 5	989172 20-21	T126A 42	5C11E 84	HS-660 85
802 5		T127A 42	5C12M, P, W 84	HS-661 85
808 5	Emerson Radio	T130A, B 43	5C13+ 85	HS-662 86
811 8	834X 33	T131A, B 43	5C14+ 85	HS-663 85
816 8	877 32	T132A, B 43	5C16NW, W 85	HS-666 87
American	888 34	T135A 44	5C15+ 86	HS-667 87
Motors	890 33	T210A 45	5K11+ 89	HS-668 87
8990576 69	891B 33	C400A 46	5P21B, N, R 78	HS-670 88
8990582 68	892A 33	C401A 46	5P22+ 81	HS-673 89
	893B 33	C405A, B 47	5P23+ 81	HS-675 90
Arvin	894B 33	C406A, B 47	5R14N 88	HS-678 91
2581 13	895B 35	C435A 48	5T11G, M 82	HS-679 92
2584 15	896B 37	C440A 49	5T11R, W 82	HS-680 93
2585 12	898B 38	C441A 49	5T12+ 83	HS-688 94
3588 14	902 37	P671A, B 54	5T13+ 83	GV-701 75
5583 15	903 38	P672A, B 54	6K13+ 90	HS-703 95
5581 17	970 37	P673A, B 54	6P25E, N, S 79	HS-704 96
8583 17	also 38	P674B 54	6T15N, S 93	HS-735 97
			6X28B, N 80	GV-800 76

VOLUME R-19, MOST-OFTEN-NEEDED 1959 RADIO SERVICING INFORMATION

Motorola, Cont.	Pontiac	Sylvania, Cont.	Westinghouse+	Westinghouse+
8990576 69	988976 26-27	1107 137	H-46AC3 166	V-2506-2 167
8990582 68	988977 30-31	1108 138	H-48SE1 168	V-2506-3 167
	988978 20-21	1303 139	H-48SE2 168	
Oldsmobile		1304 140	H-48SE3 168	Zenith Radio
989170 28-29	RCA Victor	2108 137	H-48SE4 168	SRS2 172
989171 30-31	LBT2 131	2109 138	H-48SE5 168	3B30 170-171
989172 20-21	LBT3 132	2305 140	HR102S 164	3Z04 169
	AK-1 127	4312 136	HR103S 164	4B22 170
Olympic Radio	C-1 133	4413 142	HF-110AN 165	4B23 170
688 98	X-1 133	4416 141	HF-111AN 165	4B24 172
	SA-2 124	4419 141	H-629T4A 151	4B25 172
Packard-Bell	X-2 133	4422 142	H-630T4A 151	5B01 173
5R5 99	BC-3 131		H-631T4A 151	5B04 174
6RT2 100	SA-3 124	Trav-ler	H-632T5A 154	5B06 174
	BCS-4 131	48-314 143	H-633T5A 154	5B10 175
Philco Corp.	SES-6 128	90-105 144	H-636T6A 155	5B11 175
T-3 (early) 101	9TX2 130	TR-280A 143	H-637T6A 155	5B20 176
T-3 (late) 102	SHP-11 126	TR-281A 143	H-649T7A 156	5B22 177
T-4 103	SHS-11 126	TR-282A 143	H-650T7A 156	5B24 178
T-4J 103	SHP-12 127	TR-283A 143	H-655P5 157	6B05 179
T-5 104	SHP-13 127		H-656P5 157	6B06 180
T-6 110	SHP-14 129	Truetone, see	H-657P5 157	BP6B, L, V 181
T-7X 105	HF-99 125	Western Auto	H-659P4 158	7A03 182
T-60 106	RS-151B 124		H-660P4 158	7AT44Z1 190
T-65 107	RS-157D 125	United Motors	H-662P4 159	7AT45Z1 185
T-75 108	RS-171A 126	see Delco	H-663P4 159	7AT47Z 187
RT-150 122	RS-172 127		H-664P4 159	7AT47Z2 187
RT-202 109	RS-175 128	Wards, see	H-666P5 160	7AT47Z4 187
T-600 110	RS-175A 129	Montgomery	H-667P5 160	7AT48Z 184
G-681 111	RC-1156C 130		H-677T4 152	7AT48Z2 184
H-691 112	RC-1187 131	Webcor	H-678T4 152	7AT48Z4 184
G-749 113	RC-1187A 132	14X278-1 145	H-679T4 152	BP7F 181
G-751 113	RC-1188 133	14X278-2 145	H-681T5 161	8AT41Z2 186
G-753 113	RC-1188A 133	14X280-1 146	H-682T5 161	8AT42Z2 188
G-755 113		14X280-2 148	H-683T5 161	SRS10 178
G-820 114	Roland	14X307 147	H-685P8 162	SRS15 178
G-822 114	71-483 134	73X014-1 145	H-686P8 162	HF110G, J 169
G-824 114		1953 145	H-690P5 163	SF112 172
G-826 114	Spartan	1954-1 146	H-693P8 153	HF116E, R 176
G-828 114	51-01 135	1956 147	H-694P8 153	HF117 177
G-974 115	51-04 135	1963 148	H-695P8 153	HF118 177
G-978 116	51-07 135	1991 145	V-2239-6 152	SF174R 170
SA-1000 120	51-09 135		V-2239-7 151	SF177E, R 170
G-1407 119	51-11 135	Western Auto	V-2278-5 153	200 184
G-1409 118		D2832A 149	V-2390-4 154	450 185
G-1410 117	Sylvania Elec.	D2832B 149	V-2391-6 155	B509C, + 175
SA-1500 122	1-609-7 136	D2834A 149	V-2392-4 156	B511B, + 175
G-1606,S 120	1-629-1,2 137	D2834B 149	V-2393-1 157	B513F, L 173
G-1706,S 122	1-630-1,2 138	DC2988A 150	V-2394-1 158	B513V, Y 173
G-1707,S 122	1-631-1 139	DC2989A 150	V-2394-2 159	B514F, + 174
G-1708S 121	1-632-1,2 140		V-2394-3 160	B515B, + 174
G-1806S 121	1-639-1 136	Westinghouse	V-2395-1 161	B615, F, + 179
G-1807S 121	1-640-1 141	H-44AC1A 167	V-2396-1 162	HF660 180
G-1808S 121	1-642-1 141	H-44AC2A 167	V-2397-1 163	B728C, + 182
G-1809S 121	1-645-1 142	H-45AC1A 167	V-2502-5 164	750L 186
G-1811S 121	SC03 136	H-45AC2A 167	V-2503-2 165	760 188-189
G-1813S 121		H-46AC1 166	V-2503-3 166	850 187
SA-2000 121		H-46AC2 166	V-2503-5 168	900 190